



OPERATING AND MAINTENANCE MANUAL

HUBBELL ENDURANCE CE 110

9/6/23



-IMPORTANT

Always reference the full model number and serial number when calling the factory.

HUBBELL ELECTRIC HEATER COMPANY
45 SEYMOUR STREET
STRATFORD, CT 06615

PHONE: (203) 378-2659

FAX: (203) 378-3593

www.hubbellheaters.com

Table of Contents

SECTION I - GENERAL INFORMATION	5
GENERAL DESCRIPTION.....	5
TANK	5
HEATING ELEMENT	5
TEMPERATURE HIGH LIMIT SWITCH	5
CONTROL THERMOSTAT	5
OUTER SHELL AND INSULATION	6
THERMOSTATIC MIXING VALVE (Optional).....	6
WALL BRACKET.....	6
SECTION II – INSTALLATION GUIDELINES	7
UNPACKING AND INSPECTING THE HEATER	7
WATER HEATER PLACEMENT	7
PIPING INSTALLATION	8
FILLING THE HEATER	8
ELECTRICAL INSTALLATION	8
Wiring Diagram	10
INSTALLATION WITHOUT THERMOSTATIC MIXING VALVE.....	10
INSTALLATION WITH THERMOSTATIC MIXING VALVE.....	11
SECTION III - SCHEDULED MAINTENANCE AND OPERATION	12
MAINTENANCE AND OPERATION	12
FREEZING.....	12
QUARTERLY INSPECTION	12
ANNUAL INSPECTION	13
LONG TERM SHUT DOWN	13
EMERGENCY	13
SECTION IV - TROUBLESHOOTING	14
SECTION V - SERVICING & REPLACEMENT OF PARTS	15
SURFACE TEMPERATURE HIGH LIMIT CUT-OFF	15
HEATING ELEMENT	15
THERMOSTAT	16
RELIEF VALVE	16
SECTION VI – WARRANTY	17
LIMITED WARRANTY AND TANK REPLACEMENT POLICY	17
LIMITED WARRANTY - TEN YEAR.....	17

TANK REPLACEMENT POLICY - TEN YEARS..... 17
CONDITIONS AND LIMITATIONS 18
HOW TO OBTAIN SERVICE ASSISTANCE 18

The following information should be noted at time of installation and retained for future reference.

Serial No.: _____

Date Installed: _____

Dealer's Name: _____

Address: _____

City and State: _____

 **WARNING / CAUTION**

1. Please read all instructions prior to installing the water heater.
2. Tank is to be completely filled with water and all air is to be vented before energizing.
3. Due to the rigors of transportation, all connections should be checked for tightness before the heater is placed in operation.
4. Safety relief valve must be installed in tapping provided.
5. The refractory material used in heating elements may absorb some moisture during transit, periods of storage, or when subjected to a humid environment. This moisture absorption may result in a cold insulation resistance of less than one (1) megohm. If this heater has been subjected to the above condition, the heating element must be checked for insulation resistance before energizing. A low megohm condition can be corrected by removing the terminal hardware and baking the element in an oven at 300°F - 500°F for several hours or until the proper megohm reading is obtained.
6. **KEEP AWAY FROM LIVE ELECTRICAL CIRCUITS.**

Do not perform any maintenance or replace any components inside the control panel with the high voltage power supply turned on. Under certain circumstances, dangerous potentials may exist even when the power supply is off. To avoid casualties, always turn the power supply safety switch off, turn the charge or ground the circuit before performing any maintenance or adjustment procedure.
7. This appliance is designed to store water heated only by the electrical elements provided, at temperatures of not more than 125°F and pressures of not more than 150 psi. Heat input from any external or additional source will void the warranty.
8. The design anticipates the proper installation and care in use of the product. There is a risk of property damage and personal injury inherent in these or any hot water system. The Company cannot supervise the installation and therefore make it a specific condition of the warranty that the customer will supervise the installation and use of this product to be sure they are performed in accordance with safe guidelines and proper local or national codes. Generalized instructions and procedures cannot anticipate all situations. For this reason, only qualified installers should perform the installations. A qualified installer is a person who has licensed training and a working knowledge of the applicable codes, regulation, tools, equipment, and methods necessary for safe installation of an electric resistance water heater. If questions regarding installation arise, check your local plumbing and electrical inspectors for proper procedures and codes. If you cannot obtain the required information, contact the company.

PARTS LOCATION DIAGRAM

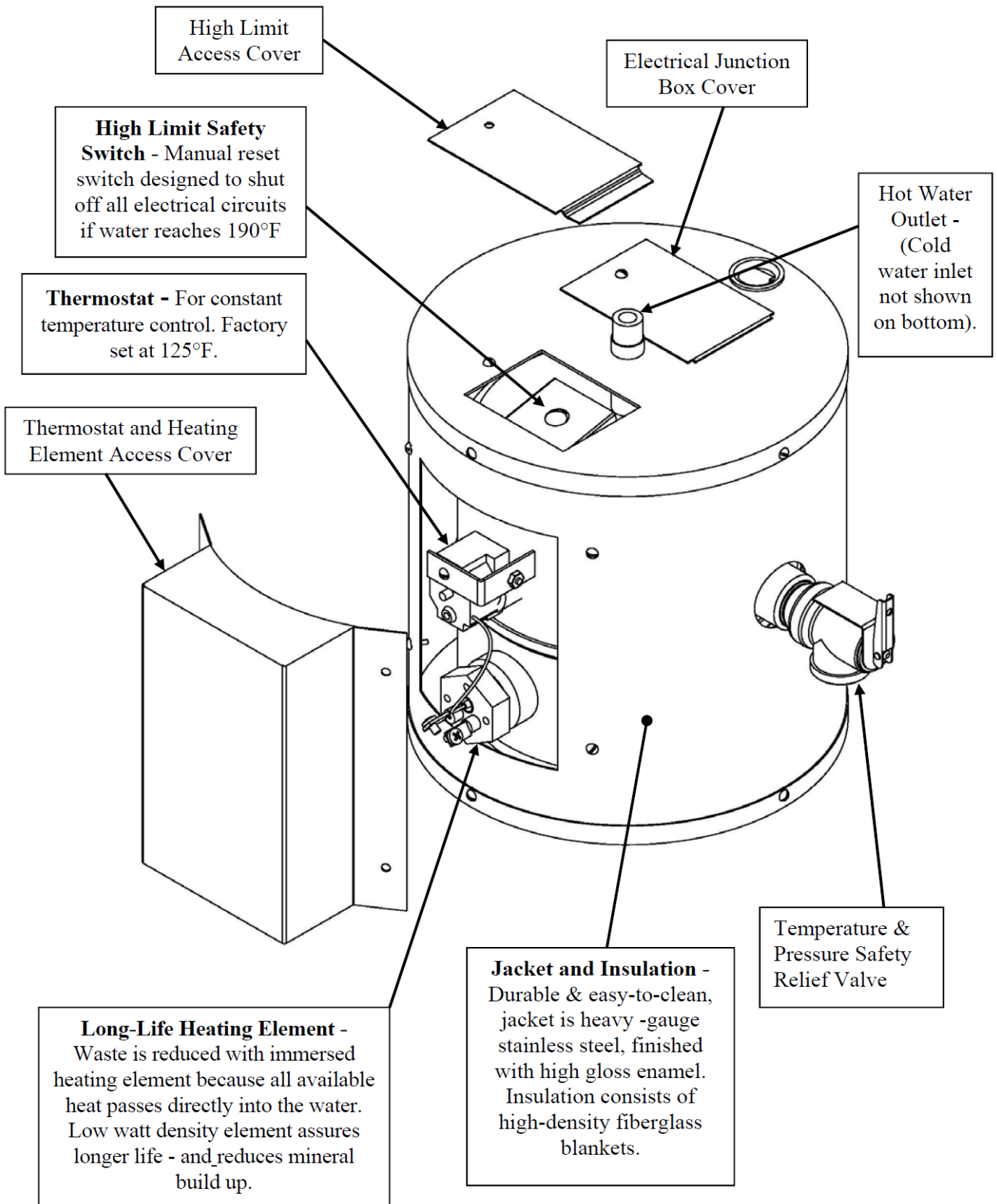

SECTION I - GENERAL INFORMATION

GENERAL DESCRIPTION

This book describes a packaged electric water heater that is a stationary, self-contained unit. The complete assembly consists of the storage tank, immersion electric heating element(s), thermostat, safety relief valve, safety high temperature cut out, and any other required electrical operating control. Optional equipment may be supplied with your unit. Please consult the product drawing for details specific to your assembly. The unit is factory assembled, insulated, jacketed, wired, tested, and ready for electrical and plumbing service connections.

CONSTRUCTION

TANK

The one-gallon storage tank is constructed of stainless steel and is designed for a maximum allowable working pressure of 150 psi (300 psi TP).

TANK CONNECTIONS

The heater is supplied with separate ¼" MNPT cold water and hot water connections. A ¾-inch FNPT connection is located on the side of the heater for mounting a combination safety temperature and pressure relief valve. An overflow line should be utilized from the relief valve outlet to a floor drain. See drawing for locations and sizes.

HEATING ELEMENT

The water heater is supplied with either a 1000 watt or a 450-watt electric immersion heating element assembly, rated for 120 volts, and composed of a copper sheathed element that is brazed into a 1" NPT brass plug.



TEMPERATURE HIGH LIMIT SWITCH

As a safety device, a surface mounted high temperature cut-off switch with manual reset, factory set at 190° F, is provided. In the event of an over-temperature condition, the thermostat will disengage the power from the system. If this switch operates, **do not attempt to reset**. A dangerous situation is indicated and a qualified service person should be called to find the source before the unit is operated again.



Manual Reset

CONTROL THERMOSTAT

The temperature of the water in the heater is regulated by the adjustable, automatic, immersion thermostat located behind the jacket front cover. This automatic control is set at the factory to maintain a water temperature of 125°F to reduce the risk of scald injury. The thermostat dial is graduated with markings from 1 to 10 with 10 being the hottest.

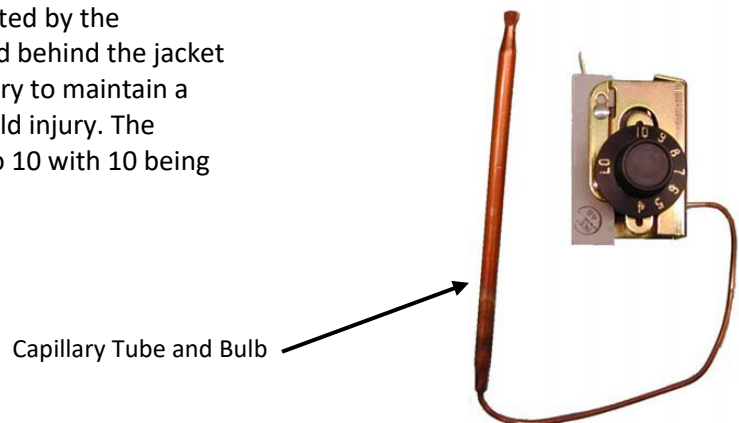

Capillary Tube and Bulb

OUTER SHELL AND INSULATION

The tank is encapsulated in 1-inch-thick fiberglass insulation. The tank and insulation is protected by a stainless-steel protective jacket.

THERMOSTATIC MIXING VALVE (Optional)

An optional thermostatic mixing valve listed in accordance with ASSE 1017, ASSE 1069, and ASSE 1070 may be supplied to increase the amount of available hot water and limit the hot water temperature to the fixture(s). The ½" NPT valve is adjustable from 80° - 120° F and is typically used when supplying hot water to multiple lavatories from a single CE110.

WALL BRACKET (Optional)

An optional wall bracket is available for easy mounting of the heater.



SECTION II – INSTALLATION GUIDELINES

WARNING / CAUTION

DO NOT TURN ON THE ELECTRIC POWER SUPPLY to this equipment until the heater is completely filled with water and all air has been released. *If the heater is NOT filled with water when the power is turned on, the heating elements will burn out.*

For protection against excessive pressures and temperatures, local codes require the installation of a temperature-and-pressure (T&P) relief valve certified by a nationally recognized laboratory that maintains periodic inspection of production of listed equipment of materials, as meeting the requirements for Relief Valves and Automatic Gas Shutoff for Hot Water Supply Systems. ANSI Z21.22-1971. A relief valve is designed to discharge excessively hot water. THE CUSTOMER IS RESPONSIBLE TO PROTECT PROPERTY AND PERSONNEL FROM HARM WHEN THE VALVE FUNCTIONS.

All water heaters have a risk of leakage at some unpredictable time. IT IS THE CUSTOMER'S RESPONSIBILITY TO PROVIDE A CATCH PAN OR OTHER ADEQUATE MEANS, SO THAT THE RESULTANT FLOW OF WATER WILL NOT DAMAGE FURNISHINGS OR PROPERTY.

The warranty provided assures replacement within its terms, but specifically does not warrant against consequential damage caused by failure to follow these instructions.

UNPACKING AND INSPECTING THE HEATER

- Remove the model CE110 from the shipping carton and visually inspect for any sign of damage. A damaged unit **should not** be installed but returned to the factory for replacement.

WATER HEATER PLACEMENT

- Locate the heater in a clean, dry location nearest to the point of most frequent hot water use.
- Secure the water heater. Optional wall mounting brackets may be utilized, if supplied.
- The water heater should be protected from freezing and waterlines insulated to reduce energy and water waste.
- Leave sufficient room to service the heater.
- Do not install in an area where flammable liquids or combustible vapors are present.

PIPING INSTALLATION

NOTE: The most effective means for preventing deterioration from accelerated corrosion due to galvanic and stray current is the installation of dielectric fittings/unions. The installation of these fittings is the responsibility of the installation contractor.

1. Connect the cold-water inlet and hot-water outlet to the appropriate connections as shown; refer to installation diagram.
2. Provide a shut off valve in the cold-water line. Mark for future emergency use.
3. If pressure reducers or any other restrictions are put in the cold-water line, special precautions should be taken. Consult your local plumbing inspector.
4. Install the combination temperature and pressure safety relief valve in the tapping provided. Note that this is required by law for safety considerations.
5. Install a relief valve overflow pipe to a nearby floor drain. **CAUTION:** No valve of any type should be installed between the relief valve and tank or in the drain line.

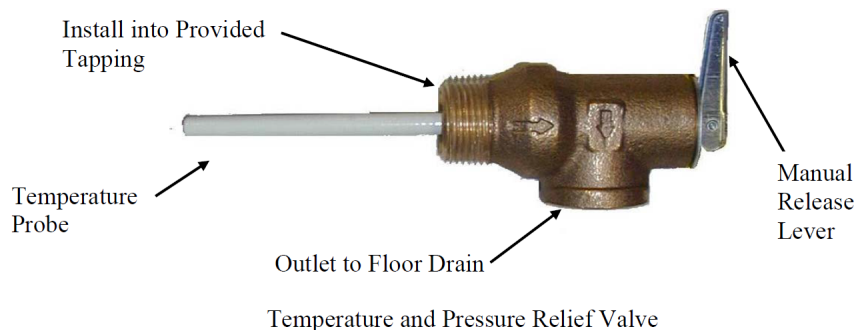

FILLING THE HEATER

1. Completely close the drain valve.
2. Open the highest hot-water faucet to allow all air to escape from piping.
3. Open the valve to the cold-water inlet and allow the heater and piping system to completely fill, as indicated by a steady flow of water from the open faucet.

ELECTRICAL INSTALLATION

1. Enter the electrical service entrance with properly sized feeder leads, conforming to the voltage stamped on the rating plate. Note: A separate fused branch circuit, conforming to local or National Electric Codes, must be provided by a qualified electrician.
2. Connect these power leads to wires enclosed in junction box with wire nuts. Refer to wiring diagram.
CAUTION: There is a risk of electric shock in an ungrounded service. It is critical that this unit be wired with a power supply that has a service ground wire available. Be sure to connect the ground wire to the green ground wire provided in the junction box.
3. Mark the electrical shut off clearly for future emergency use.
4. Field connections with aluminum conductors must use connectors approved for copper to aluminum connection.
5. All other electrical connections are made at the factory; therefore, no other electrical connections are necessary.

FINAL CHECKS

1. Check all connections for tightness.
2. Complete the following checklist to ensure that all the above steps are completed:
 - a. ___ Unit unpacked and checked for damage.
 - b. ___ Heater properly located.
 - c. ___ Heater properly secured to wall.
 - d. ___ Cold water line connected to cold water inlet on tank.
 - e. ___ Shut-off valve installed on cold water line.
 - f. ___ Hot water line connected to hot water outlet on tank.
 - g. ___ Temperature and pressure relief valve installed.
 - h. ___ Relief valve overflow line installed.
 - i. ___ Water heater filled with water.
 - j. ___ Power leads connected inside electrical enclosure from separate fused circuit.
 - k. ___ Ground wire connected.
3. After the water is heated for the first time, monitor the water temperature as described in Section III, Quarterly Inspection.

Wiring Diagram

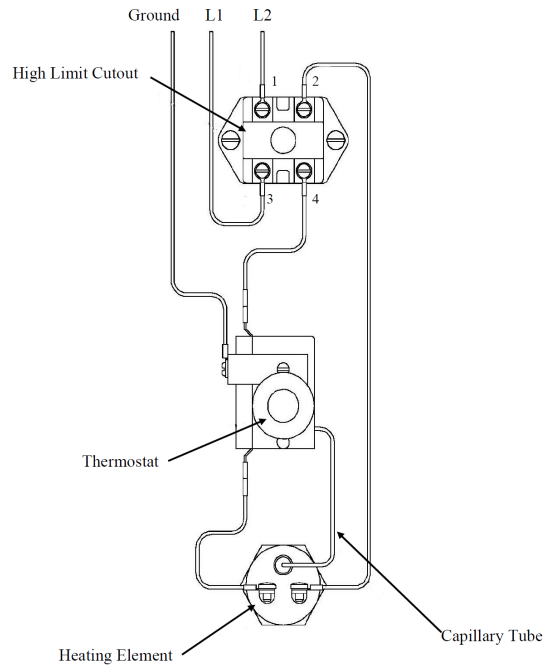

INSTALLATION WITHOUT THERMOSTATIC MIXING VALVE

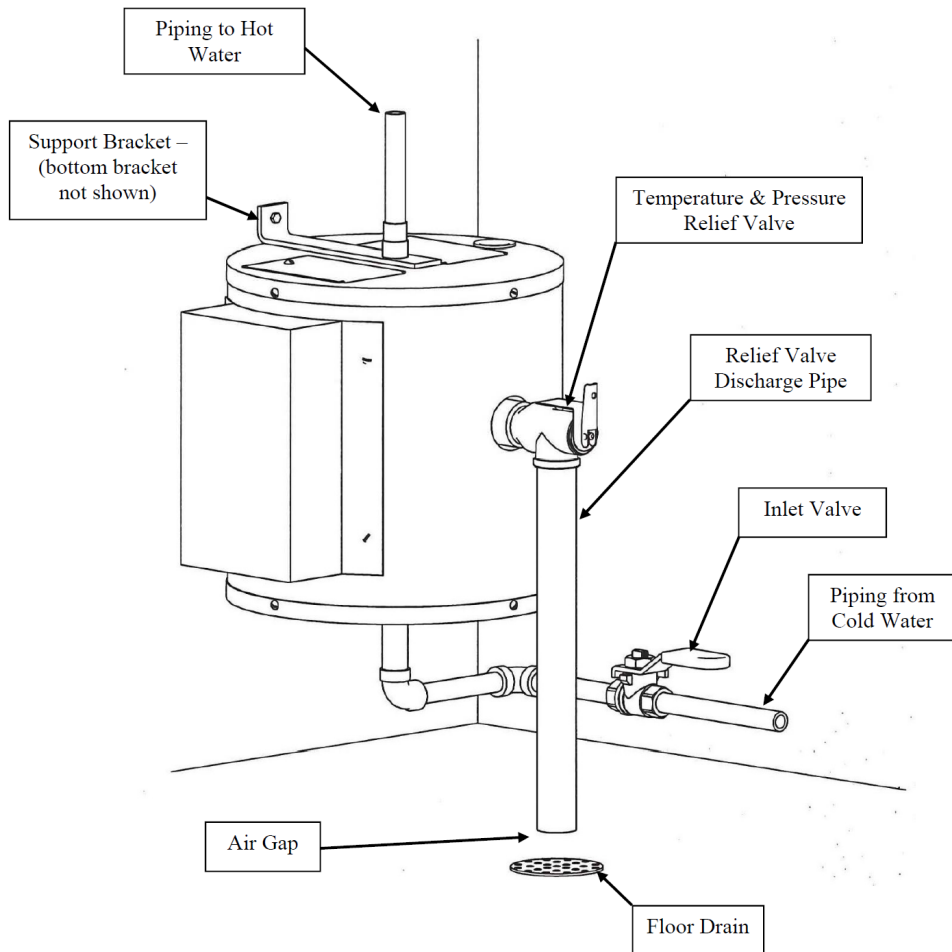

INSTALLATION WITH THERMOSTATIC MIXING VALVE

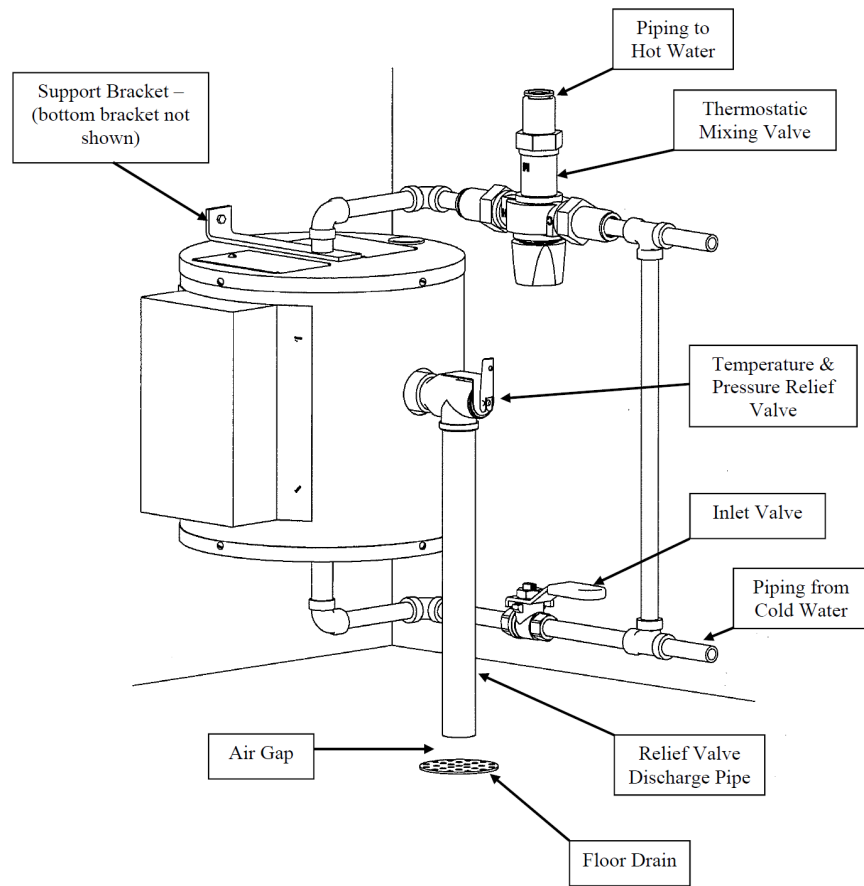

SECTION III - SCHEDULED MAINTENANCE AND OPERATION

WARNING / CAUTION

Before performing any maintenance procedure, make certain power supply is **OFF** and cannot accidentally be turned on.

Exposure to 125°F or hotter water can cause scalding injuries. Appropriate caution must be taken when using hot water. Special supervision must be given to those who cannot react quickly such as children, invalids, or elderly persons.

MAINTENANCE AND OPERATION

The water heater is automatic in its operation. It will maintain a full tank of water at the temperature setting of the thermostat. The water heater should not be turned on without first making sure that the tank is full of water and that all air has been released.

FREEZING

The tank should be fully drained in the event the electricity has been turned off and if there is danger of freezing.

QUARTERLY INSPECTION

1. Water temperature regulation.
 - a. Let the water heater completely heat to a designated thermostat setting.
 - b. After the thermostat satisfies (i.e., when the thermostat actually clicks off), draw water from the heater.
 - c. Measure the maximum temperature with an accurate thermometer.
 - d. If the temperature is above the safe limits for your circumstances call a service man to adjust or replace the control.
2. Lift test lever on relief valve and let water run through valve for a period of approximately 10 seconds. This will help flush away any sediment that might build up in water passageways.
3. Inspect element flange for leakage as follows:
 - a. Shut off the Power Supply.
 - b. Remove element housing cover.
 - c. Visually inspect the heating element for evidence of leaks.
 - d. Rub your finger around the heating element and check for any evidence of moisture. If moisture is present or a water drip is observed, follow the procedure outlined in Section V.
4. Check for loose electrical connections. Tighten as necessary.

ANNUAL INSPECTION

1. Flush tank as follows:
 - a. Shut off the Power supply.
 - b. Attach a hose to the drain valve installed in the cold-water piping.
 - c. Close valve on the cold-water line to the heater.
 - d. Open the drain valve and direct the water to a drain.
 - e. Open the hot water faucet to admit air into the tank.
 - f. Close drain valve and hot water faucet.
 - g. Open valve on the cold-water line to the heater.
 - h. Turn the power supply ON.

LONG TERM SHUT DOWN

1. If the water heater is to remain idle for an extended period of time, the power and water to the heater should be turned off to conserve energy.
2. The water heater and piping should be drained if they might be subjected to freezing temperatures.
3. After a long shutdown period, the heater's operations and controls should be checked by qualified service personnel.
4. Make certain the water heater is filled before placing it in operation.

EMERGENCY

1. Should the heater be subject to flood, fire, or other damaging conditions, turn off the power and water to the heater.
2. **DO NOT** place the water heater in operation again until it has been thoroughly checked by qualified service personnel.

SECTION IV - TROUBLESHOOTING

Symptom	Probable Cause	Corrective Action / Remedy
No hot water	Circuit breaker tripped at source	Reset circuit breaker
	High limit switch tripped	Reset high limit switch
	Loose wires	Tighten wires.
	Heating element inoperable	Check heating element operation by clamping an ammeter around each wire to the element. The ampere reading should agree with the nameplate 'AMP' figure.
	Low line voltage	Have source electrical system checked by an electrician
	Faulty thermostat	Move thermostat dial through full range. A definite 'click' should be heard. If not, replace thermostat
Water temperature below settings at all times	Faulty thermostat	Check thermostat adjustment. Monitor thermostat as described in Section III, Quarterly Inspection. Replace if necessary
Relief valve discharges continuously	Excessive temperature or pressure in tank	Temperature and pressure relief valves are made to operate if the water temperature exceeds 210°F or water pressure exceeds the pressure rating of the safety relief valve. If trouble is excessive temperature, then thermostat is not shutting off at the right setting and thermostat must be replaced

SECTION V - SERVICING & REPLACEMENT OF PARTS

WARNING / CAUTION

Before servicing or replacing any part make sure to turn the power supply switch to the **OFF** position.

SURFACE TEMPERATURE HIGH LIMIT CUT-OFF

1. Disconnect power from unit.
2. Remove access cover.
3. Disconnect the four (4) 14-gauge wires.
4. Remove the two (2) mounting screws.

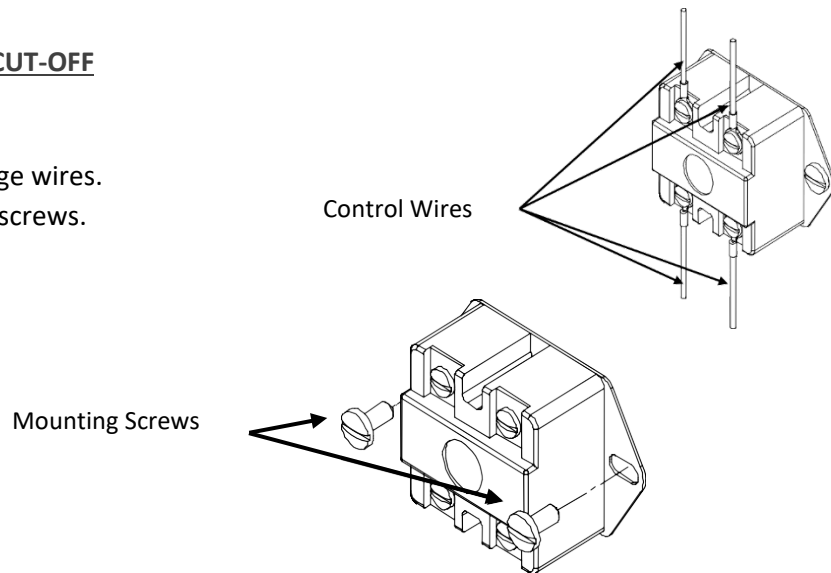

5. Replace control and install new high limit switch by performing above steps in reverse order; refer to wiring diagram in Section II.

HEATING ELEMENT

1. Disconnect power from unit.
2. Shut off incoming water supply.
3. Attach hose to drain connection.
4. Lift manual release lever on relief valve to let air into system or break union on
6. outgoing water line.
5. Drain water from tank.
6. Remove access cover.
7. Disconnect the wires from the heating element terminals.
8. Unscrew the heating element.
9. Withdraw element assembly.

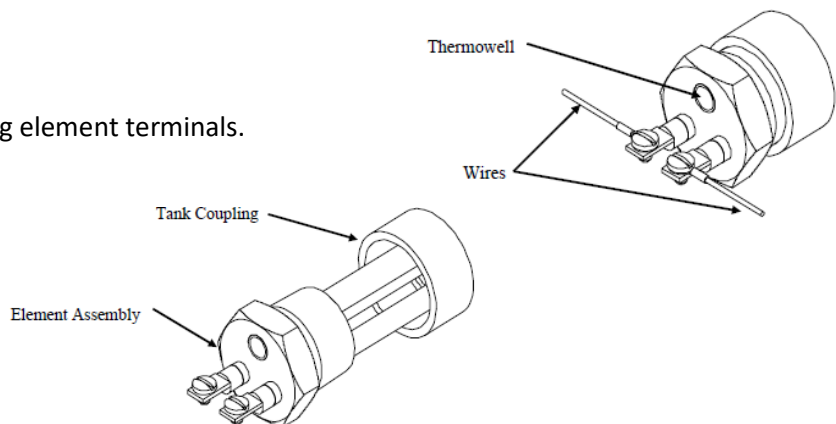

10. Install Teflon tape and insert new heating element. Thermowell must be above the heating element, in the 12 o'clock position.
11. Rewire element; refer to the wiring diagram in Section II.
12. Reinstall access cover.
13. Fill the tank and check around element for any leaks.

THERMOSTAT

1. Disconnect power from unit.
2. Remove access cover and locate thermostat.
3. Disconnect the two (2) control wires.

4. Remove capillary tube and bulb from thermowell in element. See previous page.
5. Remove mounting screw and knob.
6. Remove thermostat by sliding out from behind mounting bracket.
7. Replace thermostat using the reverse procedure; refer to the wiring diagram in Section II.

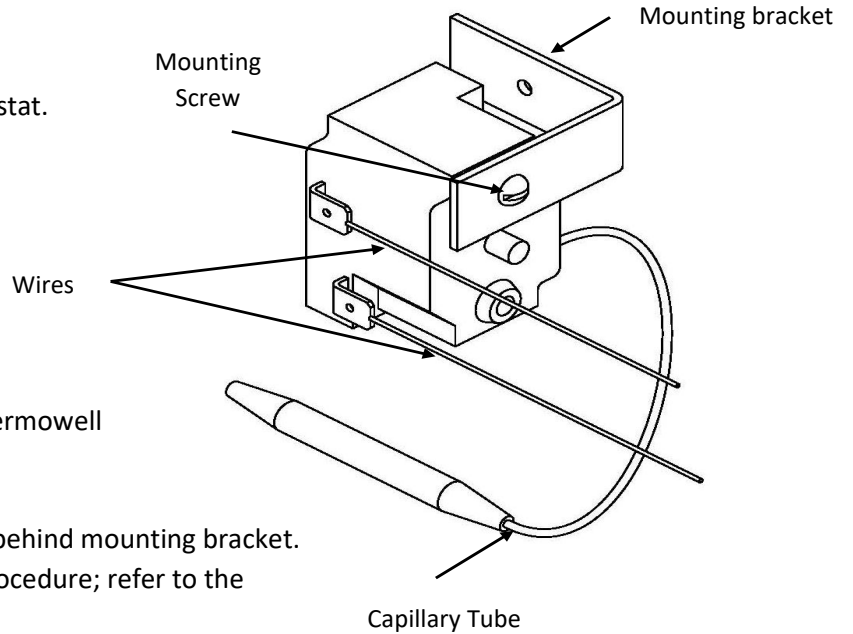

RELIEF VALVE

1. Disconnect power from unit.
2. Shut off incoming water supply.
3. Lift test lever on relief valve to relieve pressure in tank.
4. Disconnect overflow piping.
5. Unscrew relief valve, remove assembly, and replace with new one.
6. Connect overflow piping.
7. Turn on incoming water supply and check for leaks.
8. Turn the safety switch to ON position.

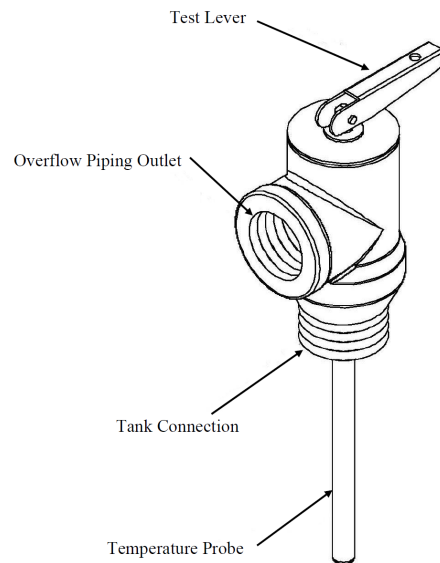

SECTION VI – WARRANTY

LIMITED WARRANTY AND TANK REPLACEMENT POLICY

The Electric Heater Co., (hereinafter called, the "Company"), offers the following warranty to the purchaser/owner of this electric water heater. Carefully read the entire warranty. Once you buy this product, the Company assumes you agree with the conditions and limitations of this warranty, and you accept the purchaser's/owner's responsibility for installation and care of the heater.

LIMITED WARRANTY - TEN YEAR

This section outlines the terms of the LIMITED WARRANTY on workmanship and material including merchantability and fitness for the intended use.

Duration: The warranty is effective for ten years, beginning with the date of original installation or ten years and 30 days from date of manufacture, whichever is sooner.

Coverage: The warranty covers any part proven to be defective in workmanship or material. In addition, it covers any part that fails due to the corrosive effect of water. Recovery under the terms of this agreement is subject to prior approval by the Company.

Company Obligations: Repair or replacement is at the option of the Company. The purchaser must pay for transportation, service, labor, reinstallation, or other costs involving the repair or replacement of such part.

Limitations: All repairs or replacements will be made F.O.B. the Company. The purchaser must pay for transportation, service, labor, reinstallation, or other costs involving the repair or replacement of such part.

Your Action: When you discover a defect, immediately notify the dealer from whom the heater was purchased. If you cannot locate the dealer, contact an authorized Hubbell dealer who stock heater parts and who has trained service personnel, or contact the Company.

TANK REPLACEMENT POLICY - TEN YEARS

This section outlines the ten-year (limited) replacement policy for tanks that fail due to the corrosive effects of water.

Duration: Ten years from date of original installation or ten years and 30 days from date of manufacture, whichever is sooner.

Coverage: Replacement Policy covers the storage tank only, and only for leaks caused by corrosive effects of water under normal and proper domestic use. Recovery under the terms of this agreement is subject to prior approval by the Company.

Company Obligation: Repair of the original tank or replacement of the entire heater with a new comparable model is at the option of the Company and constitutes the fulfillment of ALL the obligations of the Company hereunder.

Replacement: When a replacement is made under the terms of this policy, the replacement unit will have a policy of replacement only for the remaining time under the original policy. The Company reserves the right to require the return of the defective unit at the expense of the purchaser.

Limitation: All repairs or replacements will be made F.O.B. the Company. The purchaser must pay for transportation, service, labor, reinstallation, or other costs involving the repair or replacement of such part.

Your Action: When you discover a defect, immediately notify the dealer from whom the heater was purchased. If you cannot locate the dealer, contact an authorized Hubbell dealer who stock heater parts and who has trained service personnel, or contact the Company.

CONDITIONS AND LIMITATIONS

Limited Warranty and tank Replacement Policy are valid only if you comply with the following conditions and limitations. It is not possible for the manufacturer to supervise the installation and use of this product. Therefore, it is a necessary and specific condition of this Limited Warranty and Tank Replacement Policy that the manufacturer relies on the diligence of the purchaser/owner in the installation and future use. Diligence on the part of the user is essential to reduce the risk from known hazards associated with water heaters.

Installation: The heater must be installed in accordance with established codes and the manufacturer's guidelines. It must not be removed from the place of original installation.

Complete Contract: This warranty and replacement policy is not complete without the installation manual attached, included and made a part of this agreement.

Specific Limitations: Parts not manufactured by us carry only the original manufacturer's warranty. This warranty and replacement agreement contains a number of provisions, each one of which stands on its own merits. If any provision or part thereof shall be declared invalid, the remaining provisions (or parts thereof) shall remain in full force and effect. This is the only warranty for this heater made by the Company. It does not authorize Company representatives or any other persons to vary the terms of this warranty or to assume for the Company any other obligations or liabilities with respect to this product.

Any implied warranty is limited to the warranty term of this agreement and will not extend beyond that one-year limitation. The parts of this warranty (including the incorporated user's manual) that speaks specifically to terms and condition are deemed specific and not to be implied in contradiction.

HOW TO OBTAIN SERVICE ASSISTANCE

Should you have any questions about your new water heater concerning service adjustment, repair, or routine maintenance, first contact your installer, plumbing contractor, or service agency.

In the event that the firm, for whatever reason, is unable to help, refer to the telephone directory commercial listing for local utility or qualified service assistance.

If neither action has solved your problem, contact The Electric Heater Company as follows:

HUBBELL ELECTRIC HEATER COMPANY
45 SEYMOUR STREET
STRATFORD, CT 06615

PHONE: (203) 378-2659

FAX: (203) 378-3593

Hubbellheaters.com

When contacting The Electric Heater Co., The following information should be made available:

1. Model and serial numbers of the water heater as listed on the front cover of this manual or on the rating plate on the heater.
2. Address where water heater can be seen.
3. Name and address of dealer from whom the heater was purchased and installer's name and address.
4. Date of original installation and any service work performed since then.
5. Details of the problems as you can best describe.
6. List of people who have been contacted regarding the problem.