

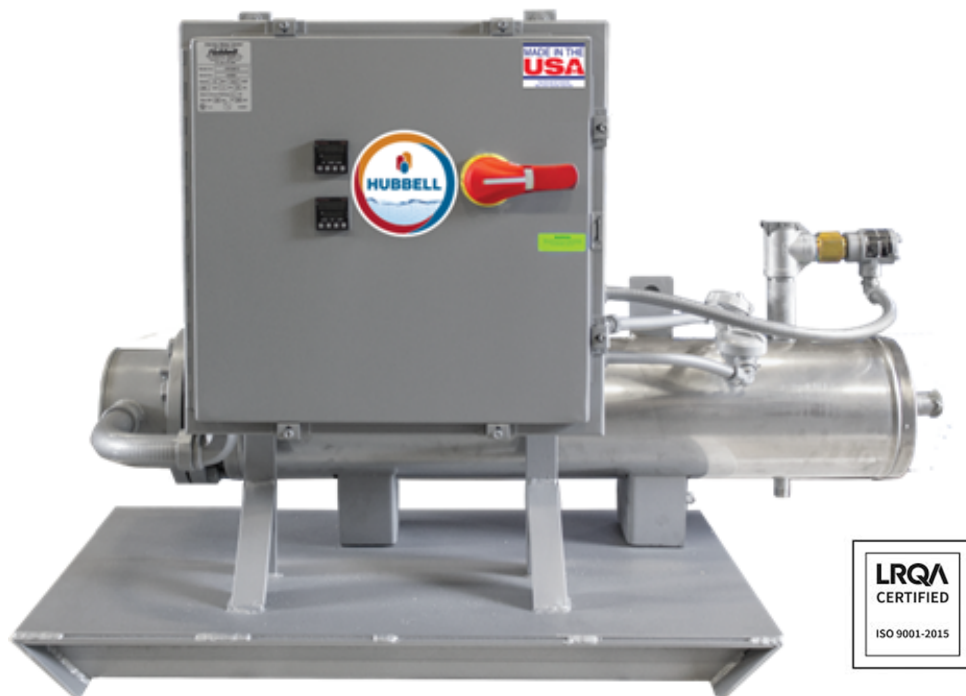

OPERATING AND MAINTENANCE MANUAL

SIGNATURE CR

7/26/23



-- IMPORTANT --

Always reference the full model number and serial number when calling the factory.

HUBBELL ELECTRIC HEATER COMPANY
45 SEYMOUR STREET
STRATFORD, CT 06615
PHONE: (203) 378-2659
FAX: (203) 378-3593
Hubbellheaters.com

Table of Contents

SECTION I – GENERAL DESCRIPTION AND CONSTRUCTION	3
GENERAL DESCRIPTION:	4
CONSTRUCTION:	4
PRESSURE VESSEL	4
VESSEL CONNECTIONS	5
OUTER SHELL, INSULATION, AND SUPPORTS	5
HEATING ELEMENT	5
FLOW SWITCH	6
CONTROL THERMOSTAT	6
TEMPERATURE HIGH LIMIT SWITCH	7
MAGNETIC CONTACTOR	7
FUSED LOW VOLTAGE TRANSFORMER	7
INDIVIDUALLY FUSED ELEMENTS	7
LOW WATER CUT-OFF	8
OPTIONS	8
SECTION II – INSTALLATION	10
HEATER PLACEMENT	10
PIPING INSTALLATION	11
FILLING THE HEATER	11
ELECTRICAL INSTALLATION	11
FINAL CHECKS	11
SECTION III - TROUBLE SHOOTING	12
SECTION IV - SCHEDULED MAINTENANCE	14
MAINTENANCE AND OPERATION	14
FREEZING	14
QUARTERLY INSPECTION	14
SECTION V - SERVICING & REPLACEMENT OF PARTS	15
MAGNETIC CONTACTOR	15
IMMERSION TEMPERATURE HIGH LIMIT CUT-OFF	16
IMMERSION THERMOSTAT	17
HEATING ELEMENT	18
RELIEF VALVE	19
SECTION VI – MISCELLANEOUS CHARTS AND FORMULAS	20

Electrical Data	22
System Element Ohms Chart.....	24
Formulas.....	27
Torque Values	28

WARNING / CAUTION

1. Tank is to be completely filled with water and all air is to be vented before energizing.
2. Due to the rigors of transportation, all connections should be checked for tightness before the heater is placed in operation.
3. Safety relief valve must be installed in tapping provided.
4. The refractory material used in heating elements may absorb some moisture during transit, periods of storage, or when subjected to a humid environment. This moisture absorption results in a cold insulation resistance of less than twenty (20) megohms. If this heater has been subjected to the above condition, each heating element must be checked for insulation resistance before energizing. A low megohm condition can be corrected by removing the terminal hardware and baking the element in an oven at 350°F – 700°F for several hours or until the proper megohm reading is obtained.
5. **KEEP AWAY FROM LIVE ELECTRICAL CIRCUITS**
Do not perform any maintenance, make any adjustments, or replace any components inside the control panel with the high voltage power supply turned on. Under certain circumstances, dangerous potentials may exist even when the power supply is off. To avoid casualties, always turn the power supply safety switch to OFF, turn the charge or ground the circuit before performing any maintenance or adjustment procedure.
6. The unit is designed to operate at pressure not more than 150 psi.
7. Generalized instructions and procedures cannot anticipate all situations. For this reason, only qualified installers should perform the installations. A qualified installer is a person who has licensed training and a working knowledge of the applicable codes, regulations, tools, equipment, and methods necessary for safe installation of an electric resistance water heater. If questions regarding installation arise, check your local plumbing and electrical inspectors for proper procedures and codes. If you cannot obtain the required information, contact the company.

SECTION I – GENERAL DESCRIPTION AND CONSTRUCTION

GENERAL SPECIFICATIONS OUTLINE DIMENSIONS

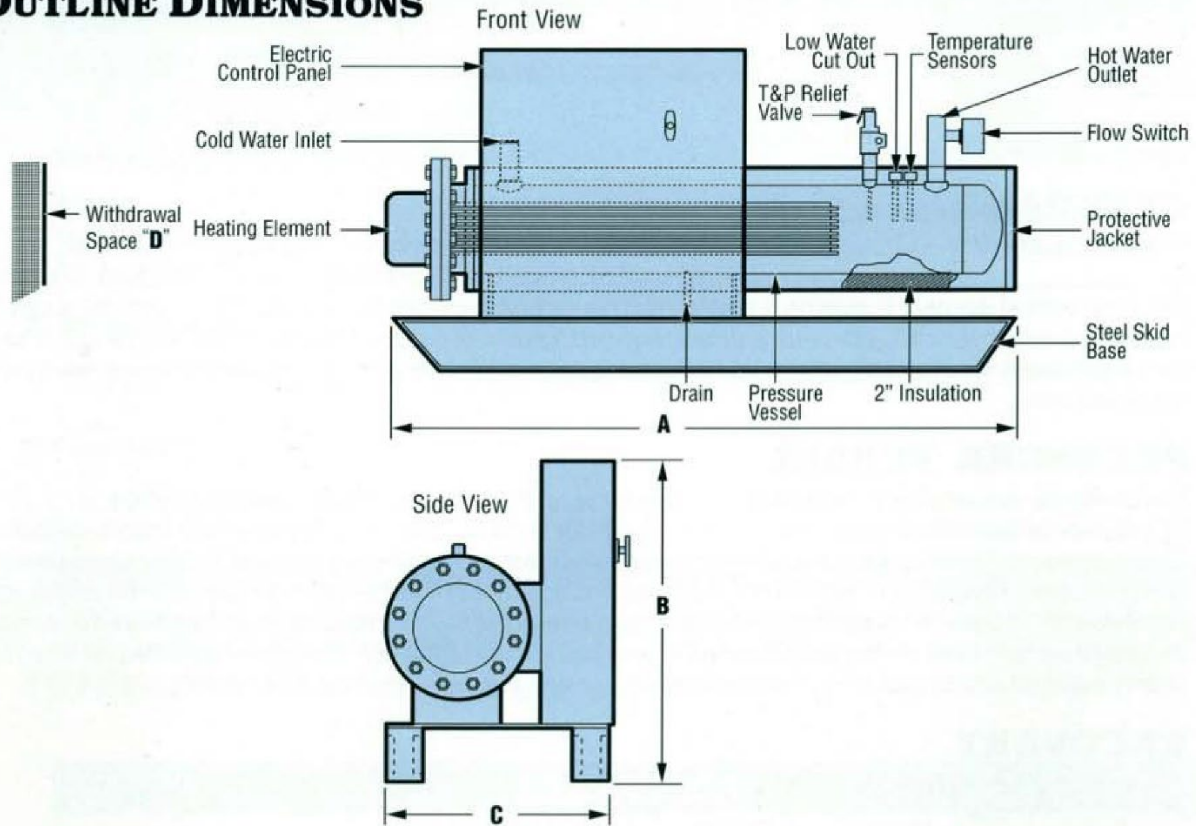

KW	Recovery Rate In GPM At °F Temperature Rise								Approx. Dimensional Data (Inches)				Inlet/Outlet (Inches)	Ampere Rating At Three Phase Power				
	10°	20°	40°	60°	80°	100°	120°	140°	A	B	C	D		208V	240V	380V	415V	480V
25	17.0	8.5	4.3	2.8	2.1	1.7	1.4	1.2	36	32	19	34	3/4 MNPT	70	60	38	35	30
45	30.7	15.4	7.7	5.1	3.8	3.0	2.6	2.2	48	32	19	40	3/4 MNPT	125	108	68	63	54
58	39.6	19.8	9.9	6.6	4.9	3.9	3.3	2.8	48	36	19	40	1.5 MNPT	161	140	89	82	71
72	49.2	24.6	12.3	8.2	6.1	4.9	4.1	3.5	54	40	24	44	1.5 MNPT	200	173	109	100	86
90	61.5	30.7	15.4	10.2	7.7	6.1	5.1	4.4	60	40	24	50	1.5 MNPT	250	217	137	126	109
120	82.9	41.0	20.5	13.7	10.2	8.2	6.8	5.9	60	48	24	50	2 MNPT	334	290	184	169	146
150	102	51.2	25.6	17.1	12.8	10.2	8.5	7.3	60	48	24	50	2 MNPT	417	362	229	211	182
175	120	59.7	30.0	19.9	14.9	11.9	10.0	8.5	60	48	24	50	2 MNPT	487	422	267	246	213
200	136	68	34	22	17	13.6	11.9	10.2	72	54	30	62	2 MNPT	555	481	304	278	240
225	153	76	38	25	19	15.3	13.7	11.7	72	54	30	62	3 FLG	625	541	342	313	270
250	170	85	42	28	21	17.0	15.9	13.7	72	54	30	62	3 FLG	694	602	380	348	301
300	205	102	51.2	34.1	25.6	20.4	17.1	14.6	72	66	36	62	4 FLG	835	724	459	419	362
350	239	120	59.7	39.8	29.9	23.8	20.0	17.1	72	66	36	62	4 FLG	974	844	535	489	423
400	273	137	68.3	45.5	34.1	27.2	22.7	19.5	84	66	36	70	5 FLG	1113	965	611	558	482
500	342	171	85.3	56.9	42.7	34.0	28.4	24.4	84	66	36	70	5 FLG	1391	1206	764	698	603
600	410	205	102	68.3	51.2	40.8	34.1	29.3	96	72	48	84	5 FLG	1669	1447	916	837	723
700	478	239	119	79.6	59.7	47.6	39.8	34.1	96	72	48	84	6 FLG	1947	1688	1069	976	843
850	581	290	145	96.7	72.5	57.8	48.4	41.4	108	72	54	96	6 FLG	—	—	1296	1184	1023
1000	683	341	171	114	85.3	68.0	56.9	48.8	108	76	60	96	6 FLG	—	—	1521	1389	1200
1200	820	409	205	137	102	81.6	68.3	58.5	108	76	60	96	6 FLG	—	—	1825	1667	1440
1400	956	478	239	159	119	95.2	79.6	68.3	108	76	60	96	6 FLG	—	—	—	1945	1681
1600	1093	546	273	182	137	108	91.0	78.0	108	76	60	96	6 FLG	—	—	—	—	1925

Notes:

1. Consult factory for vertical and wall mounted dimensions.
2. The KW selections above are shown for convenience. A full selection of KW ratings up to 1600 KW is available by simply entering the desired KW into the model number.

GENERAL DESCRIPTION:

This book describes a packaged electric heater that is a stationary, self-contained unit. The complete assembly consists of the pressure vessel, immersion electric heating element, thermostat, safety relief valve, safety high temperature cut out, magnetic contactor(s), power circuit fusing, fused low voltage control circuit transformer, and any other required electrical operating control. Optional equipment may be supplied with your unit. Please consult the product drawing for details specific to your assembly. The unit is factory assembled, insulated, jacketed, wired, tested, and ready for electrical and plumbing service connections.

CONSTRUCTION:

PRESSURE VESSEL

Standard Vessel Construction:

The standard pressure vessel is constructed of all welded carbon steel, then hot dip galvanized for added corrosion resistance. Units over 58 kW are designed and built in accordance with ASME Section IV and stamped, certified, and registered with the National Board of Boiler and Pressure Vessel Inspectors. The maximum allowable working pressure is stamped on the nameplate. The standard working pressure is 150 psi (225 psi TP).

Optional Non-Ferrous Vessel Materials:

1. Copper-Silicon – A copper-silicon alloy offers tremendous longevity due to its ability to withstand the cycling effects induced from changes in water temperature and pressure. This material is suitable for storage of hot potable water in a variety of commercial and industrial applications.
2. 90/10 Copper-Nickel – A 90% copper and 10% nickel alloy similar to copper-silicon, but with added strength and corrosion resistance. Typically used in applications with corrosive environments (salt water) or critical applications.
3. Stainless Steel – Stainless steel 316L is well suited for high purity applications requiring a corrosion resistant tank with minimal leaching of impurities into the water. Well suited for process, RO, and DI water systems in the pharmaceutical, food, and electronic industries.
4. Other materials are available upon request.

Optional Working Pressures:

The pressure vessel may be supplied with optional working pressures (standard working pressure is 150 psi). See drawing for details.

VESSEL CONNECTIONS

The heater is supplied with separate cold water and hot water connections. A connection is provided for mounting a combination safety temperature and pressure relief valve. An overflow line should be utilized from the relief valve outlet to a floor drain. See drawing for locations and sizes.

OUTER SHELL, INSULATION, AND SUPPORTS

The pressure vessel is encapsulated in 2-inches of high-density fiberglass insulation. The protective shell is constructed of galvalume and is coated with a durable silver hammertone finish. The horizontal configuration is supported on heavy-duty steel I-beam supports. Also available in a vertical configuration or wall hung for off the floor installation.

HEATING ELEMENT

The heater is supplied with a flanged electric immersion heating element assembly, composed of copper, incoloy, or stainless steel sheathed elements that are brazed or welded into a ANSI steel flange. The heating element is fastened to a corresponding tank flange using a gasket and hex head steel bolts and nuts. Specialized heating element construction may be included. These options include: special watt density ratings, passivation, electropolishing, or special materials. See the drawing specific to your heater for voltage, power ratings, and special options.

ELECTRICAL ENCLOSURE

A louvered control panel available in various sizes and with assorted types of handles is supplied. The standard cabinet is rated NEMA 1, but other NEMA rated enclosures are available, consult drawing for further information. A list of NEMA ratings are available in Section VI. An optional explosion-proof enclosure is available for hazardous locations.



FLOW SWITCH

The heater is supplied with a factory installed and wired safety flow switch. This device will allow the immersion heating element to energize only when there is sufficient flow through the unit.



CONTROL THERMOSTAT

The control panel is supplied standard with a single-stage immersion thermostatic switch. As an option any of the following may be supplied; a four-stage immersion thermostatic switch, a solid-state staging controller with thermistor, or a digital 1/16 DIN temperature controller with thermocouple. See the drawing specific to your heater for specific details. The single-stage immersion thermostat can be adjusted through a range of 100° - 190° F. A low range, (30° - 110° F), operating thermostat is also available in the single-stage version. The four-stage immersion thermostat can be adjusted through a range of 100° - 250° F and is capable of switching four circuits. The solid-state staging controller automatically brings on-line the required number of heating steps in order to meet the hot water demand and will also operate each circuit in a circular mode to allow for equal usage of all heating circuits. The thermostat is adjustable to the desired temperature by turning the dial on the pot switch. A 1/16 DIN electronic temperature control package may be installed. A separate manufacturer's operating manual will be supplied with all units except the single-stage immersion thermostat.



Single-Stage Immersion



Four-Stage Immersion Thermostat



1/16 DIN Digital Display



Solid State Staging Controller

TEMPERATURE HIGH LIMIT SWITCH

As a safety device, an immersion high temperature cut-off switch with manual reset, adjustable through a range of 100° - 240° F, is provided. The high limit must be manually reset in order to restart the heater. Optionally a 1/16 DIN digital controller may be used as a high limit.

Manual Reset →



MAGNETIC CONTACTOR

The magnetic contactor(s) is a heavy-duty resistive load type rated for 100,000 cycles. The contactor supplies power to the heating element(s) based on the resistive load (non-inductive) of the heater only when the thermostatic switch is engaged, thereby pulling in the contacts until the desired temperature is reached. At this point, the contacts will drop out, which in turn disconnects power from the elements.



FUSED LOW VOLTAGE TRANSFORMER

A fused low voltage transformer may be supplied. This option is used to step down higher voltages to 120-volt for safety when working with control circuits.

INDIVIDUALLY FUSED ELEMENTS

To prevent the possibility of damage to control circuits and other elements in case of electrical overloads, fuses may be supplied for each element. Two types of fuses may be used: a type NON for voltages less than 250-volt or type JJS for voltage less than 600-volt.

Type JJS →



← Type NON

LOW WATER CUT-OFF

Used as a safety device, the electronic low water cut-off is used to detect a low water situation and disengage the operating coils in the magnetic contactor(s). Once the condition is remedied, the low water cut-off switch is automatically reset.



Conductive Type Low Water Cut-Off Relay

OPTIONS

The following optional features may be included in your water heater. See the drawing specific to your heater for further details.

Stainless Steel Jacket

An optional stainless steel outer jacket may replace the standard galvalneal covering. This optional jacket may be painted.

On / Off Control Switch

A built-in non-fused On/Off disconnect switch may be supplied with the control panel to decrease the risk of injury when working with the control panel.

Built-In Circuit Breaker

A built-in circuit breaker may be provided with or without shunt trip protection for protection from circuit overload.

Audible Alarm

An audible alarm may be installed on the outside of the control panel to give warning of an over-temperature condition.

Building Management System (BMS)

A Building Management System control package may be supplied for remote operation and alarm capabilities.

Status Indicating Lamp(s)

Optional status indicating lamps may be installed to show when the unit is on, when the heating element is energized, or if there is an alarm condition.

Silicon Control Rectifier

An SCR "zero fired" power controller for 0-100% proportional control of heaters may be supplied.



Dial Temperature and Pressure Gauge

A combination temperature (70° - 250° F) and pressure (0 – 200 psi) gauge with 2½-inch dial may be supplied for in-line installation (shipped loose) or factory installed in the tank.



Special Customized Features

See the drawing specific to your heater for details.

SECTION II – INSTALLATION

WARNING / CAUTION

DO NOT TURN ON THE ELECTRIC POWER SUPPLY to this equipment until the heater is **completely filled with water and all air has been released**. *If the heater is NOT filled with water when the power is turned on the heating elements will burn out.*

For protection against excessive pressures and temperatures, local codes require the installation of a temperature-and-pressure (T&P) relief valve certified by a nationally recognized laboratory that maintains periodic inspection of production of listed equipment of materials, as meeting the requirements for Relief Valves and Automatic Gas Shutoff for Hot Water Supply Systems. ANSI Z21.22-1971. THE CUSTOMER IS RESPONSIBLE TO PROTECT PROPERTY AND PERSONNEL FROM HARM WHEN THE VALVE FUNCTIONS.

All water heaters have a risk of leakage at some unpredictable time. IT IS THE CUSTOMER'S RESPONSIBILITY TO PROVIDE A CATCH PAN OR OTHER ADEQUATE MEANS, SO THAT THE RESULTANT FLOW OF WATER WILL NOT DAMAGE FURNISHINGS OR PROPERTY.

HEATER PLACEMENT

1. Place the heater on a solid foundation in a clean, dry location nearest to the point of most frequent hot water use.
2. The heater should be protected from freezing and waterlines insulated to reduce energy and water waste.
3. Leave sufficient clearance for element withdrawal, if necessary.
4. Do not install in an area where flammable liquids or combustible vapors are present.

PIPING INSTALLATION

NOTE: The most effective means for preventing deterioration from accelerated corrosion due to galvanic and stray current is the installation of dielectric fittings/unions. The installation of these fittings is the responsibility of the installation contractor.

1. Connect the cold-water inlet and hot water outlet to the appropriate connections as shown; refer to the drawing specific to your heater for location and sizes.
2. Install in-line vacuum breaker and in-line pressure and temperature gauge, if supplied.
3. Install the combination temperature and pressure safety relief valve in the tapping provided. Note that this is required by law for safety considerations.

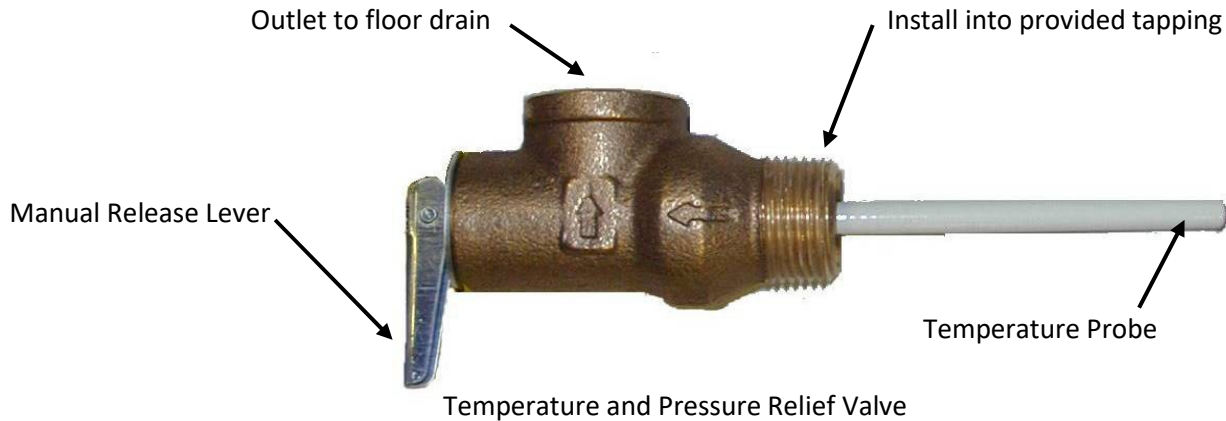

4. Install a relief valve overflow pipe to a nearby floor drain. CAUTION: No valve of any type should be installed between the relief valve and tank or in the drain line.

FILLING THE HEATER

1. Completely close the drain valve and open the highest hot water valve to allow all air to escape from piping.
2. Open the valve to the cold-water inlet and allow the heater and piping system to completely fill, as indicated by a steady flow of water from the open faucet.

ELECTRICAL INSTALLATION

1. Enter electric enclosure with properly sized feeder leads (use 60° C copper wire for water heaters rated less than 100 amps; otherwise use 75°C copper wire). Single-phase installations require two (2) leads; three phase installations require three (3) leads.
2. Install these power leads into the box lugs on the terminal block or magnetic contactor.
3. Torque screws per torque chart included in Section VI.
4. All other electrical connections are made at the factory; therefore, no other electrical connections are necessary.

FINAL CHECKS

1. Check all connections for tightness.
2. Ensure that all the above steps are completed.
3. After the water is heated for the first time, monitor the water temperature as described in Section IV, Quarterly Inspection.

SECTION III - TROUBLE SHOOTING

Symptom	Probable Cause	Corrective Action / Remedy
No hot water	Circuit breaker tripped at source.	Reset circuit breaker.
	On/Off switch in 'OFF' position, if installed.	Turn switch to "ON" position.
	Circuit breaker at control cabinet tripped, if installed.	Reset circuit breaker.
	Blown fuse in element fuse block, if installed.	Replace fuse.
	Blown fuse in transformer, if installed.	Replace fuse.
	High limit switch tripped.	Reset high limit switch.
	Loose wires.	Tighten wires. Torque screws per torque chart included in Section VI.
	Heating element inoperable.	Check heating element operation by clamping an Amprobe around each wire to the element. The ampere reading should agree with the nameplate 'AMP' figure.
	Low line voltage.	Have source electrical system checked by an electrician.
	Faulty thermostat.	Move thermostat dial through full range. A definite 'click' should be heard. If not, replace thermostat.
Faulty low water cut-off, if installed.	Check to see if the tank is full of water. If not, fill the tank. If the problem continues and the tank is full, check for continuity between the common and normally open contact of the relay board. If continuity is not observed, replace low water cut-off.	
Magnetic contactor does not energize.	Replace complete magnetic contactor. Because of the design of this particular contactor, it is more desirable to replace complete control rather than rebuilding coil, contacts and springs, etc.	
Water temperature below settings at all times	Faulty thermostat.	Check thermostat adjustment. Monitor thermostat as described in Section IV, Quarterly Inspection. Replace if necessary.
	Blown fuse in element fuse block, if installed.	Replace fuse.

	Heating element not working on all phases	Check to see that heating element is working on all phases, by checking the resistance (ohms) value for each element and comparing with the system element Ohms chart included in Section VI.
	Heater improperly sized	Verify heater is properly sized for the flow rate and temperature rise of your system. See formulas included in Section VI. Replace elements with proper size as necessary.
Relief valve discharges continuously	Excessive temperature or pressure in tank	Temperature and pressure relief valves are made to operate if the water temperature exceeds 210°F or water pressure exceeds the pressure rating of the safety relief valve. If trouble is excessive temperature, then thermostat is not shutting off at the right setting and thermostat must be replaced.

SECTION IV - SCHEDULED MAINTENANCE

WARNING / CAUTION

Before performing any maintenance procedure, make certain power supply is **OFF** and cannot accidentally be turned on.

MAINTENANCE AND OPERATION

The heater is automatic in its operation. It will maintain water at the temperature setting of the thermostat. The heater should not be turned on without first making sure that the vessel is full of water and that all air has been released.

FREEZING

The vessel should be fully drained in the event the electricity has been turned off and if there is danger of freezing.

QUARTERLY INSPECTION

1. Monitor thermostat:
 - a. Let the water heater completely heat to a designated thermostat setting.
 - b. After the thermostat satisfies (that is, when the thermostat actually clicks off), draw water from heater.
 - c. Compare the water temperature of drawn water to the temperature setting of the thermostat when it satisfies. Normal variation between the two points is approximately $\pm 5^{\circ}\text{F}$.
 - d. If these two readings do not coincide within acceptable tolerances and verification has been made of the accuracy of the temperature-reading gauge, replace the thermostat.
2. Lift test lever on relief valve and let water run through valve for a period of approximately 10 seconds. This will help flush away any sediment that might build up in water passageways.
3. Inspect element flange for leakage as follows:
 - a. Shut off Power Supply.
 - b. Remove element housing cover.
 - c. Visually inspect heating element gasket for evidence of leaks.
 - d. Rub finger around gasket that is between the heating element and tank flange for any evidence of moisture. If moisture is present or a water drip is observed, follow the procedure outlined in Section V.
4. Check for loose electrical connections. Tighten as necessary.

SECTION V - SERVICING & REPLACEMENT OF PARTS

WARNING / CAUTION

Before servicing or replacing any part make sure to turn the power supply switch to the **OFF** position.

MAGNETIC CONTACTOR

1. Disconnect power from unit.
2. Disconnect line and load wires to contactor.
3. Disconnect two (2) 14-gauge control circuit wires.

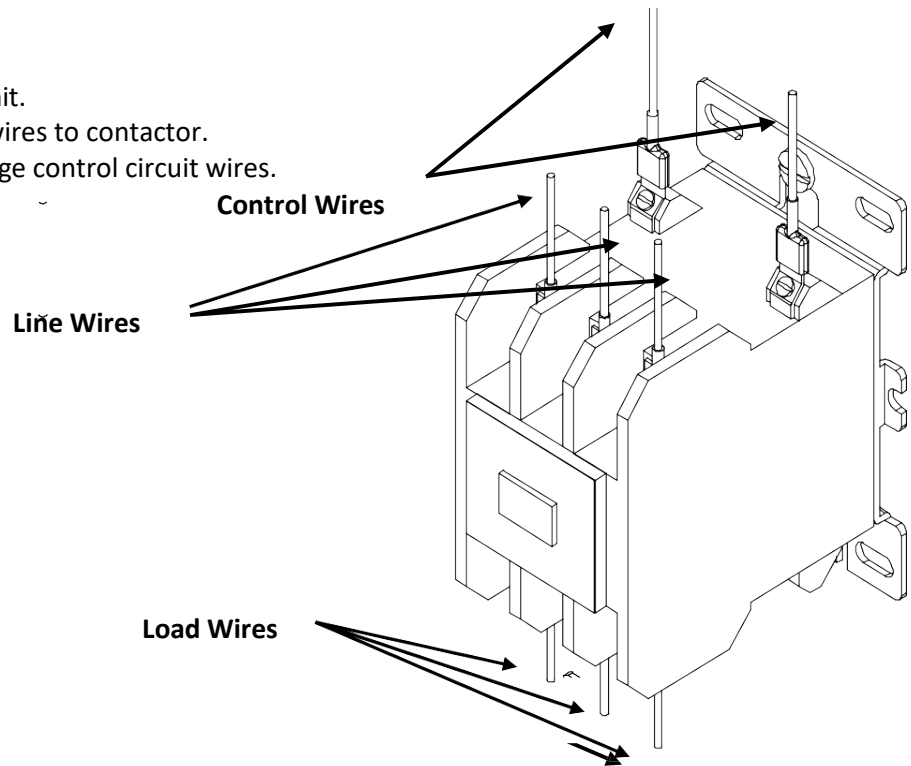

4. Loosen two (2) holding screws and remove contactor.

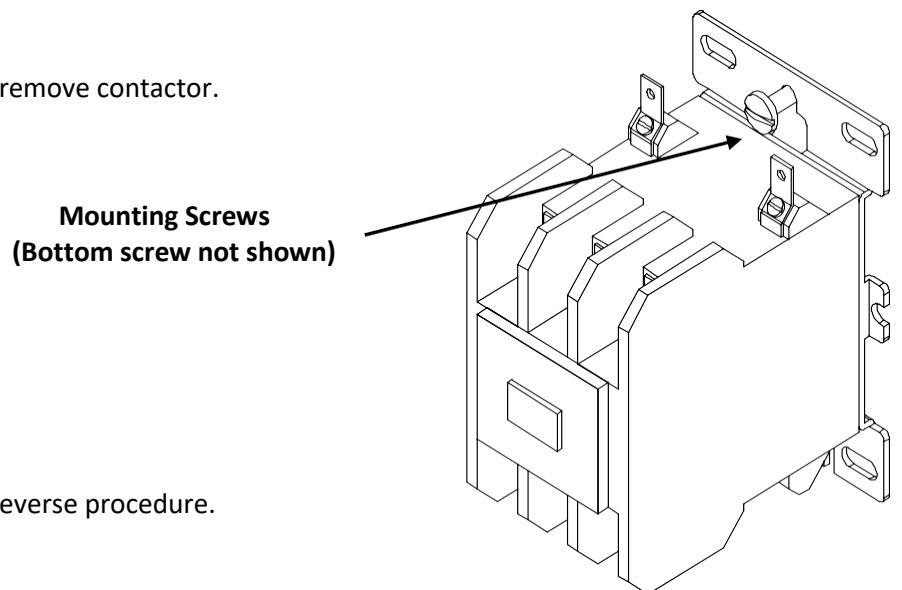

5. Replace with new contactor using reverse procedure.

IMMERSION TEMPERATURE HIGH LIMIT CUT-OFF

1. Disconnect power from unit.
2. Remove access cover.
3. Remove high limit cover screw and cover.

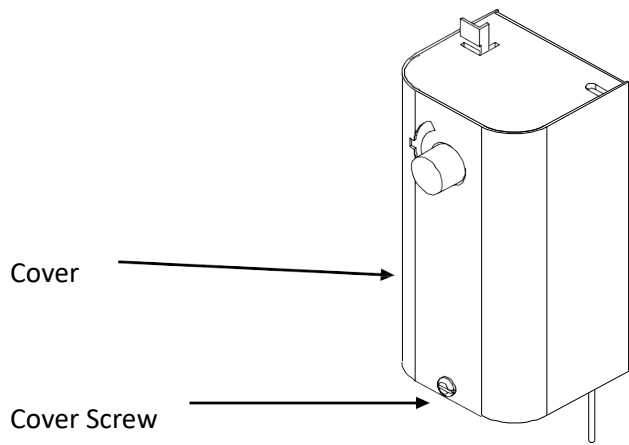

4. Disconnect the two (2) 14-gauge wires.

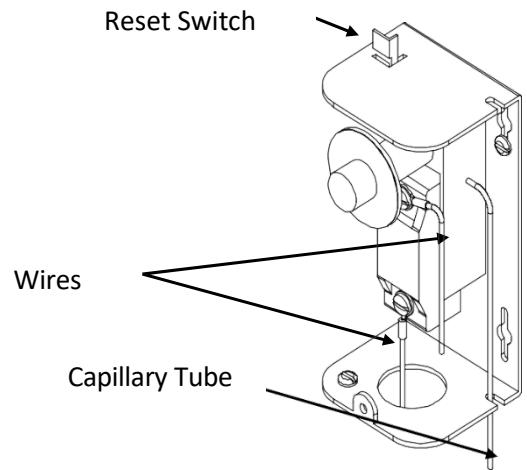

5. Remove capillary tube and bulb from thermowell.
6. Remove two (2) mounting screws.

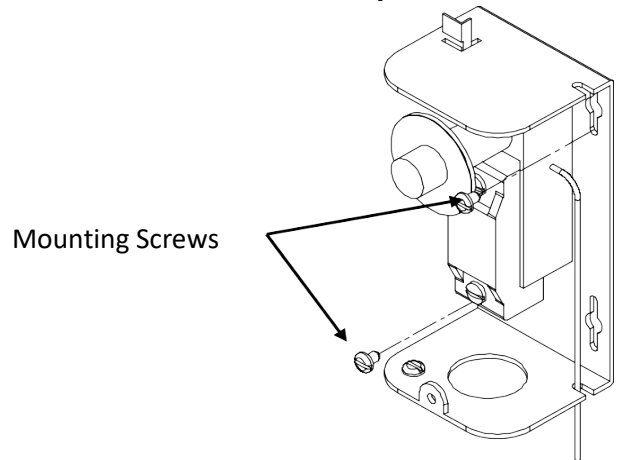

7. Remove control and install new high limit switch by performing above steps in reverse order. (Note: Be sure to place capillary tube into slot in base prior to installing cover).

IMMERSION THERMOSTAT

1. Disconnect power from unit.
2. Remove access cover and locate thermostat.
3. Remove high limit cover screw and cover.

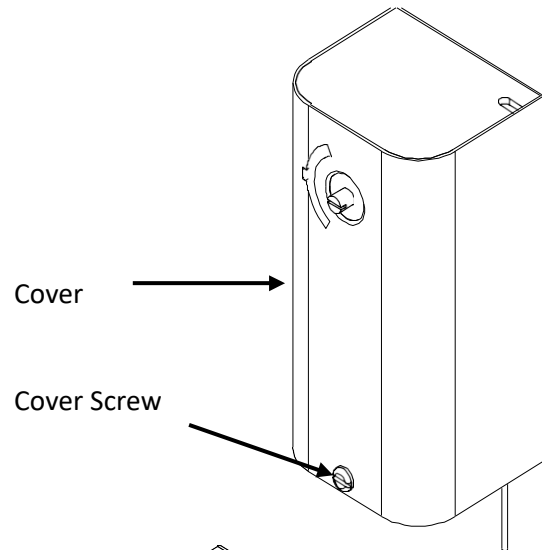

4. Disconnect the two (2) 14-gauge wires.

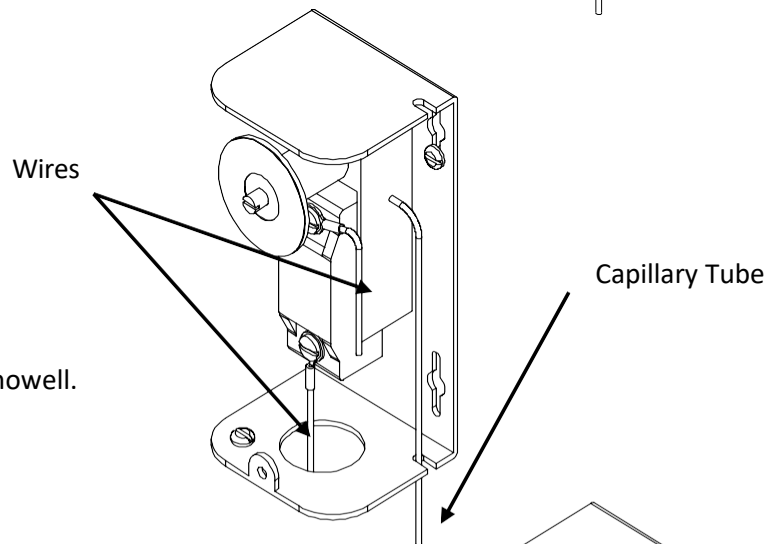

5. Remove capillary tube and bulb from thermowell.
6. Remove two (2) mounting screws.

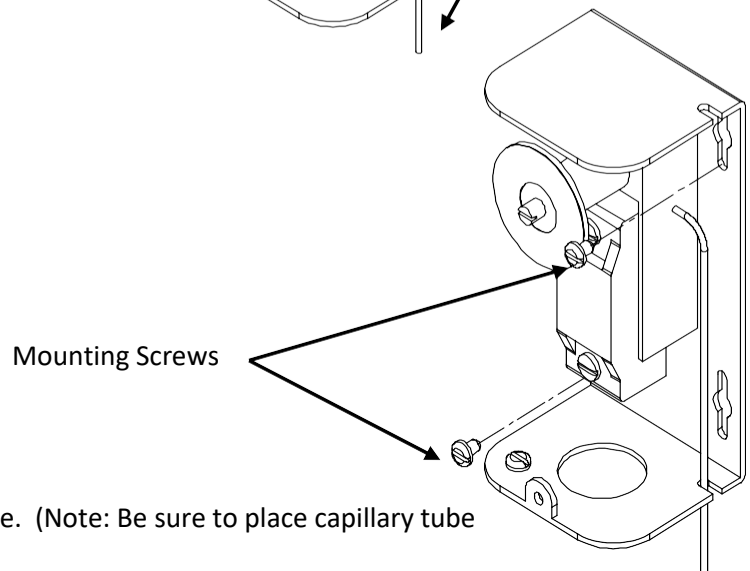

7. Replace thermostat using reverse procedure. (Note: Be sure to place capillary tube into slot in base prior to installing cover.)

HEATING ELEMENT

1. Disconnect power from unit.
2. Shut off incoming water supply.
3. Attach hose to drain connection.
4. Lift manual release lever on relief valve to let air into system or break union on outgoing water line.
5. Drain water from tank.
6. Remove element housing cover.
7. Disconnect the wires from the heating element terminals.
8. Disconnect conduit from coupling.

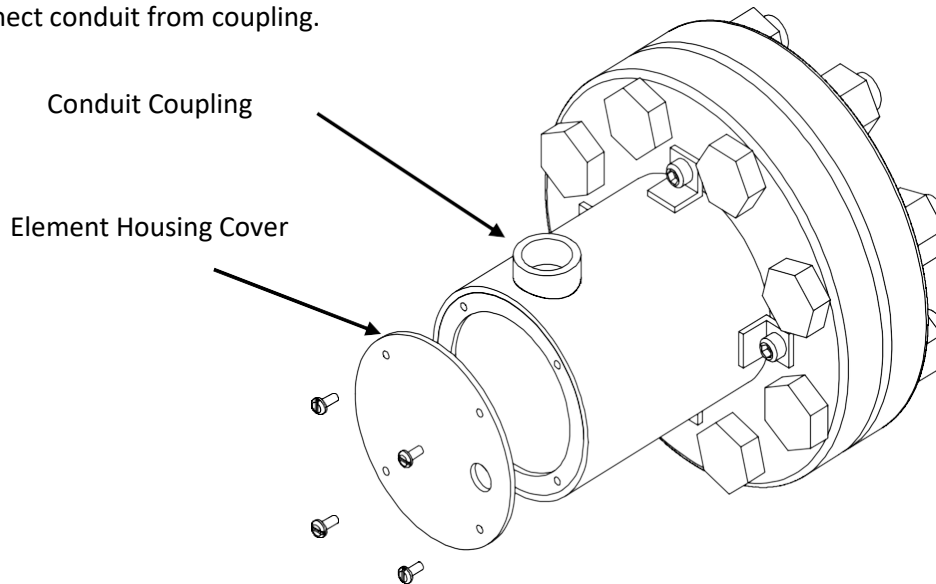

9. Remove nuts and bolts from flanges.
10. Withdraw element assembly and remove gasket.

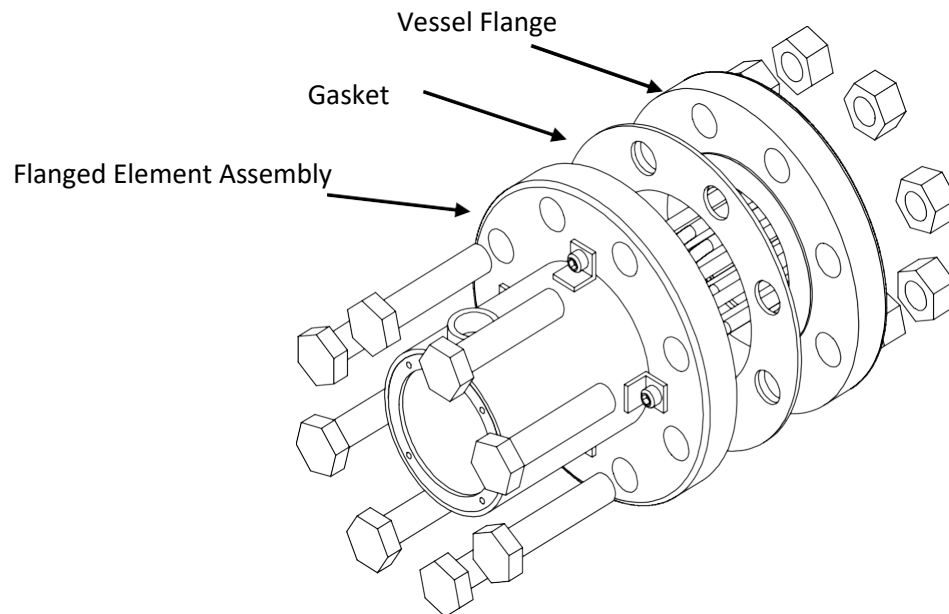

11. Install a new gasket and insert a new heating element.
12. Rewire element according to the voltage and phase rating of the unit as shown below.
13. Fill the tank and check around the gasket for any leaks.

RELIEF VALVE

1. Disconnect power from unit.
2. Shut off incoming water supply.
3. Lift test lever on relief valve to relieve pressure in tank.
4. Disconnect overflow piping.
5. Unscrew relief valve, remove assembly, and replace with new one.
6. Connect overflow piping.
7. Turn on incoming water supply and check for leaks.
8. Turn the safety switch to ON position.

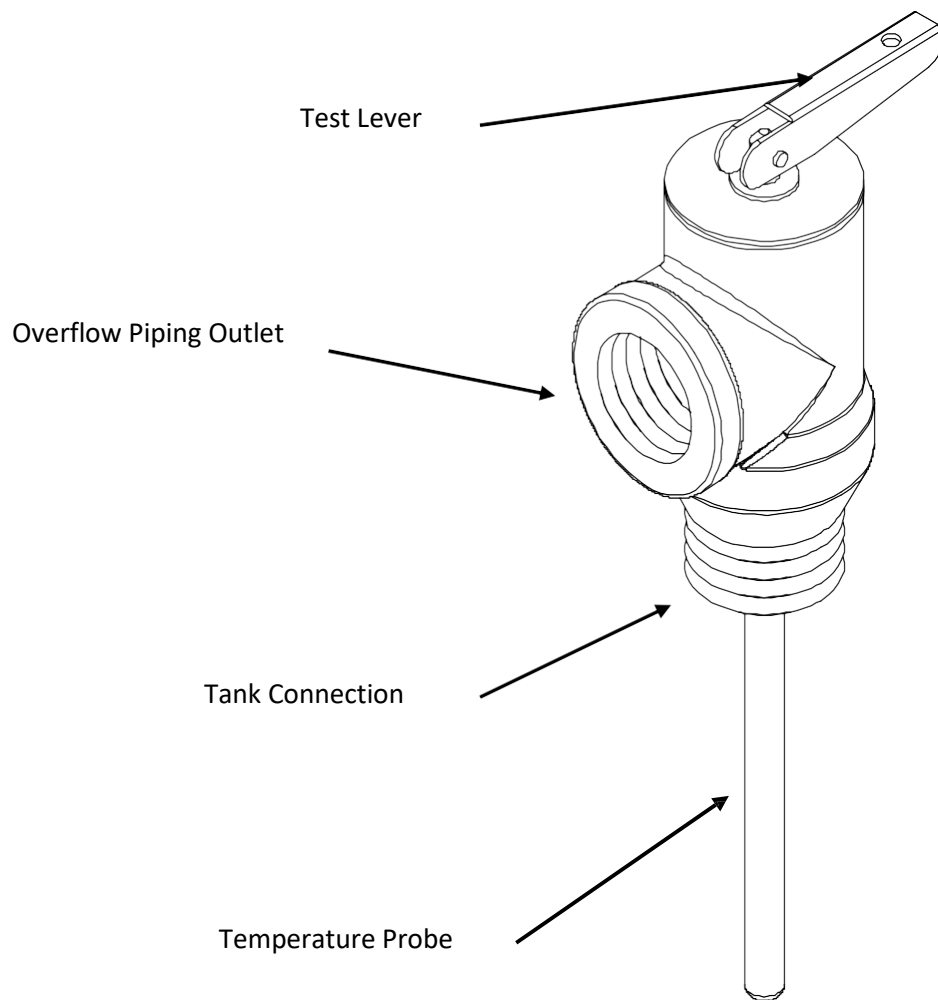

SECTION VI – MISCELLANEOUS CHARTS AND FORMULAS

NEMA ENCLOSURES

Type	Intended Use and Description
1	Enclosures are intended for indoor use primarily to provide a degree of protection against contact with the enclosed equipment or locations where unusual service conditions do not exist.
2	Enclosures are intended for indoor use primarily to provide a degree of protection against limited amounts of falling water and dirt.
3	Enclosures are intended for outdoor use primarily to provide a degree of protection against windblown dust, rain, and sleet; undamaged by the formation of ice on the enclosure.
4	Enclosures are intended for indoor or outdoor use primarily to provide a degree of protection against windblown dust and rain, splashing water, and hose-directed water; undamaged by the formation of ice on the enclosure.
4X	Enclosures are intended for indoor or outdoor use primarily to provide a degree of protection against corrosion, windblown dust and rain, splashing water, and hose-directed water; undamaged by the formation of ice on the enclosure.
12	Enclosures are intended for indoor use primarily to provide a degree of protection against dust, falling dirt, and dripping noncorrosive liquids.
13	Enclosures are intended for indoor use primarily to provide a degree of protection against dust, spraying of water, oil, and noncorrosive coolant.

The preceding descriptions are not intended to be complete representations of National Electrical Manufacturers Association standards for enclosures.

Table 1. COMPARISON OF SPECIFIC APPLICATIONS OF ENCLOSURES FOR INDOOR NON-HAZARDOUS LOCATIONS

Provides a Degree of Protection Against the Following Environmental Conditions	Type of Enclosure										
	1*	2*	4	4X	5	6	6P	11	12	12K	13
Incidental contact with the enclosed equipment	X	X	X	X	X	X	X	X	X	X	X
Falling dirt	X	X	X	X	X	X	X	X	X	X	X
Falling liquids and light splashing		X	X	X		X	X	X	X	X	X
Dust, lint, fibers, and flyings†			X	X	X	X	X		X	X	X
Hosedown and splashing water			X	X		X	X				
Oil and coolant seepage									X	X	X
Oil or coolant spraying and splashing											X
Corrosive agents				X			X	X			
Occasional temporary submersion						X	X				
Occasional prolonged submersion							X				

*These enclosures may be ventilated. However, Type 1 may not provide protection against small particles of falling dirt when ventilation is provided in the enclosure top.

†These fibers and flyings are nonhazardous materials and are not considered the Class III type ignitable fibers or combustible flyings. For Class III type ignitable fibers or combustible flyings see the National Electrical Code®, Section 500-6(a).

Table 2. COMPARISON OF SPECIFIC APPLICATIONS OF ENCLOSURES FOR OUTDOOR NON-HAZARDOUS LOCATIONS

Provides a Degree of Protection Against the Following Environmental Conditions	Type of Enclosure						
	3	3R**	3S	4	4X	6	6P
Incidental contact with the enclosed equipment	X	X	X	X	X	X	X
Rain, snow, and sleet§	X	X	X	X	X	X	X
Sleet††			X				
Windblown dust	X		X	X	X	X	X
Hosedown				X	X	X	X
Corrosive agents					X		X
Occasional temporary submersion						X	X
Occasional prolonged submersion							X

§External operating mechanisms are not required to be operable when the enclosure is ice covered.

††External operating mechanisms are operable when the enclosure is ice covered.

** These enclosures may be ventilated.

Electrical Data

ELECTRICAL DATA

Wattage Change with Voltage Change

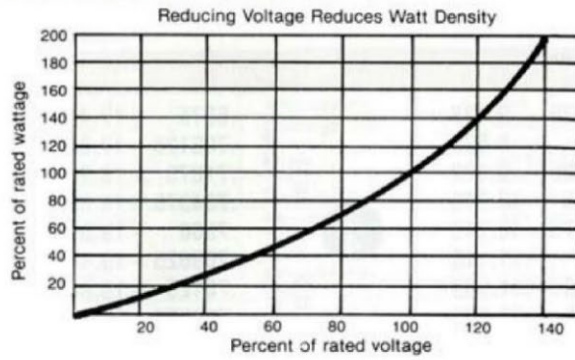

PERCENT RATED WATTS ON REDUCED VOLTAGE

230-volt heater on 208 volts—82%
 240-volt heater on 208 volts—75%
 480-volt heater on 277 volts—33%
 480-volt heater on 440 volts—84%
 480-volt heater on 318 volts—44%
 550-volt heater on 480 volts—76%

$$W_2 = W_1 \times \left(\frac{e_2}{e_1}\right)^2$$

Where:

w_2 = New wattage output
 w_1 = Rated wattage
 e_2 = Applied voltage
 e_1 = Rated voltage

ohms Law

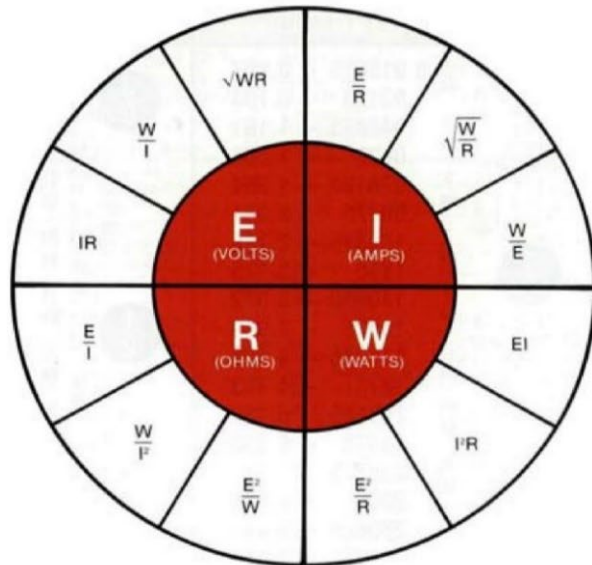

ELECTRICAL DATA

Three Phase Circuits

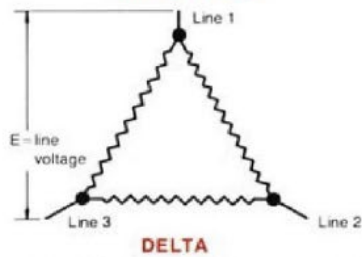
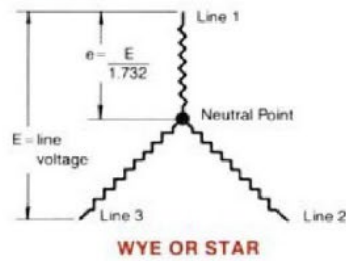

If elements are designed for 3-phase Delta connection, wattage output may be reduced to $\frac{1}{3}$ by reconnecting to 3-phase WYE

For current in 3-phase circuits
$$I = \frac{W}{E \times 1.732}$$

For resistance in 3 phase circuit (across any two terminals)

$$R = \frac{E^2}{\frac{1}{2}W}$$

Amperage Conversion Table

Watts	Volts, Single Phase			Volts 3 Phase Balanced Load		Watts
	120	240	480	240	480	
100	.83	.42	.21	.24	.13	100
150	1.25	.63	.31	.36	.18	150
200	1.67	.83	.42	.49	.25	200
250	2.08	1.04	.52	.61	.30	250
300	2.50	1.25	.63	.73	.37	300
350	2.92	1.46	.73	.85	.43	350
400	3.33	1.67	.84	.97	.49	400
450	3.75	1.88	.93	1.10	.55	450
500	4.17	2.08	1.04	1.20	.60	500
600	5.00	2.50	1.25	1.45	.73	600
700	5.83	2.92	1.46	1.70	.85	700
800	6.67	3.33	1.67	1.93	.97	800
900	7.50	3.75	1.87	2.17	1.09	900
1000	8.33	4.17	2.10	2.41	1.21	1000
1100	9.17	4.58	2.30	2.65	1.33	1100
1200	10.0	5.00	2.51	2.90	1.45	1200
1250	10.4	5.21	2.61	3.10	1.55	1250
1300	10.8	5.42	2.71	3.13	1.57	1300
1400	11.7	5.83	2.91	3.38	1.69	1400
1500	12.5	6.25	3.12	3.62	1.82	1500
1600	13.3	6.67	3.34	3.86	1.93	1600
1700	14.2	7.08	3.54	4.10	2.05	1700
1800	15.0	7.50	3.75	4.34	2.17	1800
1900	15.8	7.92	3.96	4.58	2.29	1900
2000	16.7	8.33	4.17	4.82	2.41	2000
2200	18.3	9.17	4.59	5.30	2.65	2200
2500	20.8	10.4	5.21	6.10	3.05	2500
2750	23.0	11.5	5.73	6.63	3.32	2750
3000	25.0	12.5	6.25	7.23	3.62	3000
3500	29.2	14.6	7.30	8.45	4.23	3500
4000	33.3	16.7	8.33	9.64	4.82	4000
4500	37.5	18.8	9.38	10.84	5.42	4500
5000	41.7	20.8	10.42	12.1	6.1	5000
6000	50.0	25.0	12.50	14.50	7.25	6000
7000	58.3	29.2	14.59	16.9	8.5	7000
8000	66.7	33.3	16.67	19.3	9.65	8000
9000	75.0	37.5	18.75	21.7	10.85	9000
10000	83.3	41.7	20.85	24.1	12.1	10000

System Element Ohms Chart

System Element Ohms Chart				
Recovery		Ohms Ranges		
kW	Voltage	L1-L2	L2-L3	L1-L3
	208	3.2 - 3.7	3.2 - 3.7	3.2 - 3.7
	240	4.3 - 4.9	4.3 - 4.9	4.3 - 4.9
25	380	10.9 - 12.2	10.9 - 12.2	10.9 - 12.2
	415	13.0 - 14.5	13.0 - 14.5	13.0 - 14.5
	480	17.5 - 19.4	17.5 - 19.4	17.5 - 19.4
	208	1.8 - 2.1	1.8 - 2.1	1.8 - 2.1
	240	2.4 - 2.7	2.4 - 2.7	2.4 - 2.7
45	380	6.0 - 6.8	6.0 - 6.8	6.0 - 6.8
	415	7.2 - 8.1	7.2 - 8.1	7.2 - 8.1
	480	9.7 - 10.8	9.7 - 10.8	9.7 - 10.8
	208	1.4 - 1.6	1.4 - 1.6	1.4 - 1.6
	240	1.8 - 2.1	1.8 - 2.1	1.8 - 2.1
58	380	4.7 - 5.3	4.7 - 5.3	4.7 - 5.3
	415	5.6 - 6.3	5.6 - 6.3	5.6 - 6.3
	480	7.5 - 8.4	7.5 - 8.4	7.5 - 8.4
	208	1.1 - 1.3	1.1 - 1.3	1.1 - 1.3
	240	1.5 - 1.7	1.5 - 1.7	1.5 - 1.7
72	380	3.8 - 4.3	3.8 - 4.3	3.8 - 4.3
	415	4.5 - 5.1	4.5 - 5.1	4.5 - 5.1
	480	6.0 - 6.8	6.0 - 6.8	6.0 - 6.8
	208	0.9 - 1.1	0.9 - 1.1	0.9 - 1.1
	240	1.2 - 1.4	1.2 - 1.4	1.2 - 1.4
90	380	3.0 - 3.4	3.0 - 3.4	3.0 - 3.4
	415	3.6 - 4.1	3.6 - 4.1	3.6 - 4.1
	480	4.8 - 5.4	4.8 - 5.4	4.8 - 5.4
	208	0.6 - 0.8	0.6 - 0.8	0.6 - 0.8
	240	0.9 - 1.1	0.9 - 1.1	0.9 - 1.1
120	380	2.2 - 2.6	2.2 - 2.6	2.2 - 2.6
	415	2.7 - 3.1	2.7 - 3.1	2.7 - 3.1
	480	3.6 - 4.1	3.6 - 4.1	3.6 - 4.1
	208	0.5 - 0.7	0.5 - 0.7	0.5 - 0.7
	240	0.7 - 0.9	0.7 - 0.9	0.7 - 0.9
150	380	1.8 - 2.1	1.8 - 2.1	1.8 - 2.1
	415	2.1 - 2.5	2.1 - 2.5	2.1 - 2.5
	480	2.9 - 3.3	2.9 - 3.3	2.9 - 3.3
	208	0.4 - 0.6	0.4 - 0.6	0.4 - 0.6
175	240	0.6 - 0.7	0.6 - 0.7	0.6 - 0.7
	380	1.5 - 1.8	1.5 - 1.8	1.5 - 1.8

	415	1.8 - 2.1	1.8 - 2.1	1.8 - 2.1
	480	2.5 - 2.8	2.5 - 2.8	2.5 - 2.8
	208	0.4 - 0.5	0.4 - 0.5	0.4 - 0.5
	240	0.5 - 0.7	0.5 - 0.7	0.5 - 0.7
200	380	1.3 - 1.6	1.3 - 1.6	1.3 - 1.6
	415	1.6 - 1.9	1.6 - 1.9	1.6 - 1.9
	480	2.1 - 2.5	2.1 - 2.5	2.1 - 2.5
	208	0.3 - 0.5	0.3 - 0.5	0.3 - 0.5
	240	0.4 - 0.6	0.4 - 0.6	0.4 - 0.6
225	380	1.2 - 1.4	1.2 - 1.4	1.2 - 1.4
	415	1.4 - 1.7	1.4 - 1.7	1.4 - 1.7
	480	1.9 - 2.2	1.9 - 2.2	1.9 - 2.2
	208	0.3 - 0.4	0.3 - 0.4	0.3 - 0.4
	240	0.4 - 0.3	0.4 - 0.3	0.4 - 0.3
250	380	1.0 - 1.3	1.0 - 1.3	1.0 - 1.3
	415	1.3 - 1.5	1.3 - 1.5	1.3 - 1.5
	480	1.7 - 2.0	1.7 - 2.0	1.7 - 2.0
	208	0.2 - 0.4	0.2 - 0.4	0.2 - 0.4
	240	0.3 - 0.5	0.3 - 0.5	0.3 - 0.5
300	380	0.9 - 1.1	0.9 - 1.1	0.9 - 1.1
	415	1.0 - 1.3	1.0 - 1.3	1.0 - 1.3
	480	1.4 - 1.7	1.4 - 1.7	1.4 - 1.7
	208	0.2 - 0.4	0.2 - 0.4	0.2 - 0.4
	240	0.3 - 0.5	0.3 - 0.5	0.3 - 0.5
250	380	0.9 - 1.1	0.9 - 1.1	0.9 - 1.1
	415	1.0 - 1.3	1.0 - 1.3	1.0 - 1.3
	480	1.4 - 1.7	1.4 - 1.7	1.4 - 1.7
	208	0.2 - 0.3	0.2 - 0.3	0.2 - 0.3
	240	0.2 - 0.4	0.2 - 0.4	0.2 - 0.4
400	380	0.6 - 0.8	0.6 - 0.8	0.6 - 0.8
	415	0.8 - 1.0	0.8 - 1.0	0.8 - 1.0
	480	1.0 - 1.3	1.0 - 1.3	1.0 - 1.3
	208	0.1 - 0.2	0.1 - 0.2	0.1 - 0.2
	240	0.2 - 0.3	0.2 - 0.3	0.2 - 0.3
500	380	0.5 - 0.7	0.5 - 0.7	0.5 - 0.7
	415	0.6 - 0.8	0.6 - 0.8	0.6 - 0.8
	480	0.8 - 1.0	0.8 - 1.0	0.8 - 1.0
	208	0.1 - 0.2	0.1 - 0.2	0.1 - 0.2
	240	0.1 - 0.3	0.1 - 0.3	0.1 - 0.3
600	380	0.4 - 0.6	0.4 - 0.6	0.4 - 0.6
	415	0.5 - 0.7	0.5 - 0.7	0.5 - 0.7
	480	0.7 - 0.9	0.7 - 0.9	0.7 - 0.9
	208	0.1 - 0.2	0.1 - 0.2	0.1 - 0.2
700	240	0.1 - 0.2	0.1 - 0.2	0.1 - 0.2

	380	0.3 - 0.5	0.3 - 0.5	0.3 - 0.5
	415	0.4 - 0.6	0.4 - 0.6	0.4 - 0.6
	480	0.6 - 0.7	0.6 - 0.7	0.6 - 0.7
	208	0.0 - 0.2	0.0 - 0.2	0.0 - 0.2
	240	0.1 - 0.2	0.1 - 0.2	0.1 - 0.2
850	380	0.3 - 0.4	0.3 - 0.4	0.3 - 0.4
	415	0.3 - 0.5	0.3 - 0.5	0.3 - 0.5
	480	0.5 - 0.6	0.5 - 0.6	0.5 - 0.6
	208	0.0 - 0.1	0.0 - 0.1	0.0 - 0.1
	240	0.1 - 0.2	0.1 - 0.2	0.1 - 0.2
1000	380	0.2 - 0.4	0.2 - 0.4	0.2 - 0.4
	415	0.3 - 0.4	0.3 - 0.4	0.3 - 0.4
	480	0.4 - 0.5	0.4 - 0.5	0.4 - 0.5
	208	0.0 - 0.1	0.0 - 0.1	0.0 - 0.1
	240	0.0 - 0.2	0.0 - 0.2	0.0 - 0.2
1200	380	0.2 - 0.3	0.2 - 0.3	0.2 - 0.3
	415	0.2 - 0.4	0.2 - 0.4	0.2 - 0.4
	480	0.3 - 0.5	0.3 - 0.5	0.3 - 0.5
	208	0.0 - 0.1	0.0 - 0.1	0.0 - 0.1
	240	0.0 - 0.1	0.0 - 0.1	0.0 - 0.1
1400	380	0.1 - 0.3	0.1 - 0.3	0.1 - 0.3
	415	0.2 - 0.3	0.2 - 0.3	0.2 - 0.3
	480	0.3 - 0.4	0.3 - 0.4	0.3 - 0.4
	208	0.0 - 0.1	0.0 - 0.1	0.0 - 0.1
	240	0.0 - 0.1	0.0 - 0.1	0.0 - 0.1
1600	380	0.1 - 0.2	0.1 - 0.2	0.1 - 0.2
	415	0.2 - 0.3	0.2 - 0.3	0.2 - 0.3
	480	0.2 - 0.4	0.2 - 0.4	0.2 - 0.4

Formulas

Recovery

$$\text{GPH} \times \text{_____} \text{ } ^\circ\text{F } \Delta\text{T} \times 0.00244 = \text{KW}$$

$$\text{KW} \times 410 \div \text{GPH} = \text{_____} \text{ } ^\circ\text{F } \Delta\text{T}$$

$$\text{KW} \times 410 \div \text{_____} \text{ } ^\circ\text{F } \Delta\text{T} = \text{GPH}$$

Note: 1 KW will heat 4.1 GPH at a 100°F ΔT

Electrical

$$\frac{\text{KW} \times 1000}{\text{Volts}} \div 1.73 = \text{Amps } 3\Phi$$

$$\frac{\text{KW} \times 1000}{\text{Volts}} = \text{Amps } 1\Phi$$

Metric Conversion

$$\text{Liters} \times 0.2641 = \text{Gallons}$$

$$\text{Gallons} \times 3.79 = \text{Liters}$$

$$\text{Gallons} \times 0.003785 = \text{m}^3$$

$$\text{m}^3 \times 264.2 = \text{Gallons}$$

$$1^\circ\text{C } \Delta\text{T} = 1.8^\circ\text{F } \Delta\text{T}$$

$$^\circ\text{F} = (^\circ\text{C} \times 1.8) + 32$$

$$^\circ\text{C} = (^\circ\text{F} - 32) \times 0.556$$

$$\text{psi} \times 0.06896 = \text{Bar}$$

$$\text{Bar} \times 14.5 = \text{psi}$$

$$\text{psi} \times 6.86 = \text{kPa}$$

$$\text{kPa} \times 0.1456 = \text{psi}$$

$$\text{Lbs} \times 0.4536 = \text{Kg}$$

$$\text{Kg} \times 2.2 = \text{Lbs}$$

$$\text{Watts/Sq.Cm.} \times 6.4 = \text{Watts/Sq.In.}$$

$$\text{Watts/Sq.In.} \times 0.155 = \text{Watts/Sq.Cm.}$$

Torque Values

BOLT SIZE	18-8 S/S IN.-LBS.	BRASS IN.-LBS.	SILICON BRONZE IN.-LBS.	ALUMINUM 2024-T4 IN.-LBS.	316 S/S IN.-LBS.	MONEL IN.-LBS.
4-40	5.2	4.3	4.8	2.9	5.5	5.3
4-48	6.6	5.4	6.1	3.6	6.9	6.7
5-40	7.7	6.3	7.1	4.2	8.1	7.8
5-44	9.4	7.7	8.7	5.1	9.8	9.6
6-32	9.6	7.9	8.9	5.3	10.1	9.8
6-40	12.1	9.9	11.2	6.6	12.7	12.3
8-32	19.8	16.2	18.4	10.8	20.7	20.2
8-36	22.0	18.0	20.4	12.0	23.0	22.4
10-24	22.8	18.6	21.2	13.8	23.8	25.9
10-32	31.7	25.9	29.3	19.2	33.1	34.9
1/4-20	75.2	61.5	68.8	45.6	78.8	85.3
1/4-28	94.0	77.0	87.0	57.0	99.0	106.0
5/16-18	132	107	123	80	138	149
5/16-24	142	116	131	86	147	160
3/8-16	236	192	219	143	247	266
3/8-24	259	212	240	157	271	294
7/16-14	376	317	349	228	393	427
7/16-20	400	327	371	242	418	451
1/2-13	517	422	480	313	542	584
1/2-20	541	443	502	328	565	613
9/16-12	682	558	632	413	713	774
9/16-18	752	615	697	456	787	855
5/8-11	1110	907	1030	715	1160	1330
5/8-18	1244	1016	1154	798	1301	1482
3/4-10	1530	1249	1416	980	1582	1832
3/4-16	1490	1220	1382	958	1558	1790
7/8-9	2328	1905	2140	1495	2430	2775
7/8-14	2318	1895	2130	1490	2420	2755
1-8	3440	2815	3185	2205	3595	4130
1-14	3110	2545	2885	1995	3250	3730



HUBBELL ELECTRIC HEATER COMPANY

45 SEYMOUR STREET

STRATFORD, CT 06615

PHONE: (203) 378-2659

FAX: (203) 378-3593

Hubbellheaters.com