



## Tepid Water Delivery System

Specifically designed to provide high volume tepid water for emergency fixtures. Configurable using electric, gas, steam or hydronic

**Long lasting.** HydraStone cement lining improves the longevity of the tank.

**Dependable.** The factory piped and packaged mixing valve is specifically designed for emergency safety drench systems and helps simplify installation.

**Cost efficient.** With 3" foam insulation, stand-by heat loss is reduced by over 24%, providing a highly efficient and economical solution.

**Peace of mind.** The dial gauge provides visual indication of water temperature and pressure.

- Reduces the risk of Legionella because water is stored at an elevated temperature
- Copper-silicon alloy tappings and high impact composite jacket cannot rust or corrode

### Applications

Designed specifically for tepid water delivery to an emergency drench system, typically used in industrial facilities such as oil refineries, nuclear power plants, chemical/petrochemical facilities, fertilizer plants, manufacturing and wherever safety washing is required.



# EMV

SURETEMP SERIES

### A heavy duty, reliable source for tepid water delivery

The Hubbell Suretemp EMV water heater is a packaged system designed to meet the requirements of ANSI/ISEA Z358.1-2014 for tepid water delivery to an emergency drench system. The water heater is factory piped and packaged with a mixing valve specifically designed, tested and proven for use in emergency safety shower/face/eyewash applications.

### Over 100 years of water heating expertise

Hubbell water heaters are the right choice for your commercial and industrial applications. We have water heating solutions for most energy sources with storage capacities from 6–10,000 gallons — all designed, engineered, and manufactured for reliability and longevity coupled with unparalleled support and service.

ASME option available.



## Heater Specifications

Tank	HydraStone cement lined Steel
Storage Capacity	119 Gallons (see note)
Orientation	Vertical
Voltages	120 thru 600 volt
Phase	1Φ or 3Φ
Cold Water Inlet Size	1-½" Female NPT
Tepid Water Outlet Size	1-¼" Female NPT
Drain Size	¾" GHT
Relief Valve Size	¾" Female NPT
Relief Valve Type	T&P, 210°F, 150 psi
Tank Set	Factory temp set 170°F Outflow Temp set 85°F *Other temps available
Piping	Copper Tubing
Mixing Valve Cv	10.0
Pressure Drop at 20 GPM	4 psi
Minimum Supply Pressure	30 psi
HI-Limit	190°F
Design WP	150 psi
Design TP	300 psi
Elements	Copper Sheathed
Insulation	3" Polyurethane foam
Tank Warranty	
Standard	5 year Non Pro-Rated
Optional	10 year Non-Pro Rated
Electrical	1 Year
Jacket	High Impact Colorized Composite
Color	White with Black Trim

**Note:** Alternate storage capacities are available for smaller or larger requirements. Please consult factory for sizing requirements.

## The Importance of Tepid Water

### Benefits of a tepid water safety shower/eyewash station

An emergency tepid water shower and/or eye wash are critical and required in most industrial facilities. Tepid water, which is water that is neither too hot nor too cold, is defined as water between 60°F (16°C) and 100°F (38°C) and recommended by safety standards such as ANSI Z358.1-2014.

In an emergency, once an employee is exposed to chemicals or other hazardous materials, using water that is too hot or too cold for decontamination can exacerbate the situation:

- If the water is too hot, it can scald the person, causing additional injury and pain.
- If the water is too cold, it can cause shock and hypothermia, which can also be dangerous.

Tepid water helps ensure that a person can remain under the shower or eye wash for the recommended amount of time, which is typically 15 minutes. If the water is too hot or too cold, the person may not be able to tolerate it for the recommended time, which can result in incomplete decontamination.

Overall, the use of tepid water in an industrial emergency shower and eye wash is essential for ensuring the safety and well-being of the person using it. It helps to prevent further injury, allows for adequate decontamination, and complies with multiple safety standards.



## Safety Standards

### OSHA 29 CFR 1910.151<sup>®</sup> Requirements

When the eyes or body of any person may be exposed to injurious corrosive materials, suitable facilities for quick drenching or flushing of the eyes and body shall be provided within the work area for immediate emergency use.

### ANSI/ISEA Z358.1-2014 Standard

This standard establishes universal minimum performance and use requirements for eyewash and drench shower equipment used for the treatment of the eyes, face, and body of a person who has been exposed to hazardous materials and chemicals. Delivered flushing fluid temperature in an emergency system should be tepid. The standard defines a tepid water range of 60°–100°F. This standard also establishes minimum flow requirements at 30–90 PSI and use requirements for eyewash and shower equipment for the emergency treatment of the eyes or body of a person who has been exposed to injurious materials.

- The shower must have a minimum of 20 GPM at 30 psi for 15 minutes of controlled flow
- The eyewash must have a minimum of 0.4 GPM at 30 psi for 15 minutes of controlled flow
- The eye/face wash must have a minimum of 3.0 GPM at 30 psi for 15 minutes of controlled flow
- Units must meet all individual performance requirements when all components are operated simultaneously

### The Hubbell Suretemp EMV satisfies OSHA and ANSI/ISEA tepid water requirements

- The EMV provides high volume tepid water for safety drench systems by integrating a specially designed mixing valve with a high-quality cement lined electric storage water heater.
- The EMV is designed to maintain 119 gallons of water at 170°F. This volume of water at this temperature is necessary to achieve the final flow rate of 23 GPM for 15 minutes of tepid water.
- When an emergency drench apparatus is used, the integrated mixing valve blends 170°F water from the tank with incoming cold water to achieve a continuous flow of 85°F tepid water. For 30 GPM shower heads the Hubbell EMV will provide 75°F water for 15 minutes.



## Mixing Valve Features

Packaged with the Hubbell Suretemp EMV is a triple redundant, thermostatic pressure balanced valve designed specifically for emergency safety shower/face/eyewash applications. The valve is factory mounted and piped to the water heater.

### Operational Features

- The mixing valve meets OSHA and ANSI requirements and provides constant 85°F tepid temperature output, regardless of inlet pressure and temperature variations. 85°F is ideal because it is not warm enough to open skin pores and not cold enough to deter usage.
- The EMV can achieve the high-volume demand required for a safety drench system by mixing the 170°F water in the tank with incoming cold water.
- The temperature setting is tamper proof and cannot be inadvertently adjusted in the field.
- The valve provides a full range of flows from the smallest flow of 0.4 GPM for an eyewash, to the combined 23 GPM flow for a simultaneous demand of shower, eyewash, and face wash system.

### Safety Features

The mixing valve incorporates a pressure sensing controller with a valve actuator that senses the water pressure on both the hot and cold water inlet connections.

- If hot water pressure is not present, then the actuator overrides the mixing valve, and a flow of cold water is allowed.
- If no cold-water pressure is available at the mixing valve inlet, then the hot water port will close to prevent overheated water from exiting the mixing valve.
- The valve also includes a safety override feature that continuously senses the final mixed water temperature.
- If the final water temperature is overheated, the valve automatically closes the hot water port and fully opens the cold water port.

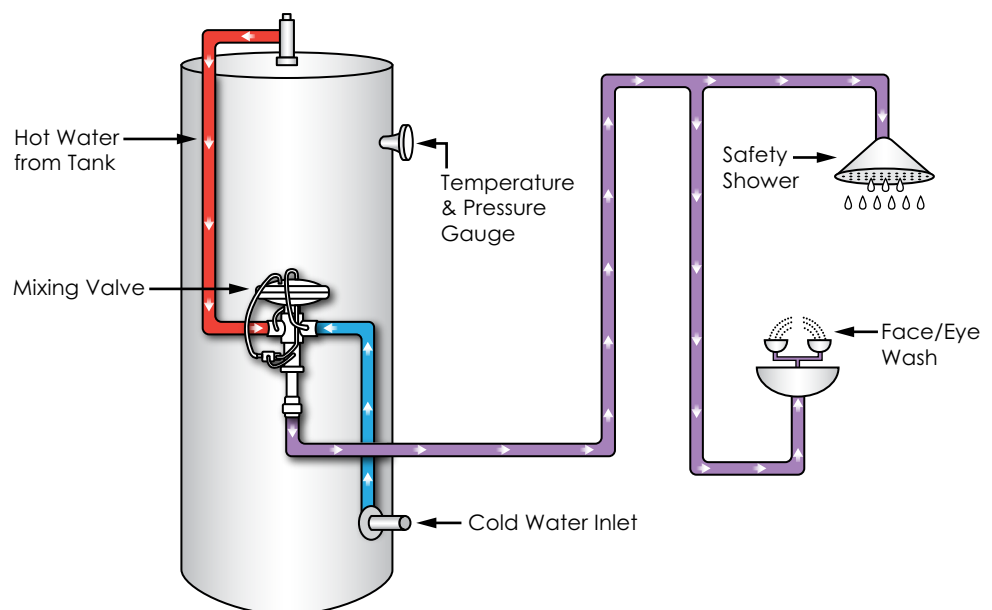

## Dimensions

Shipping weight 875 lbs.

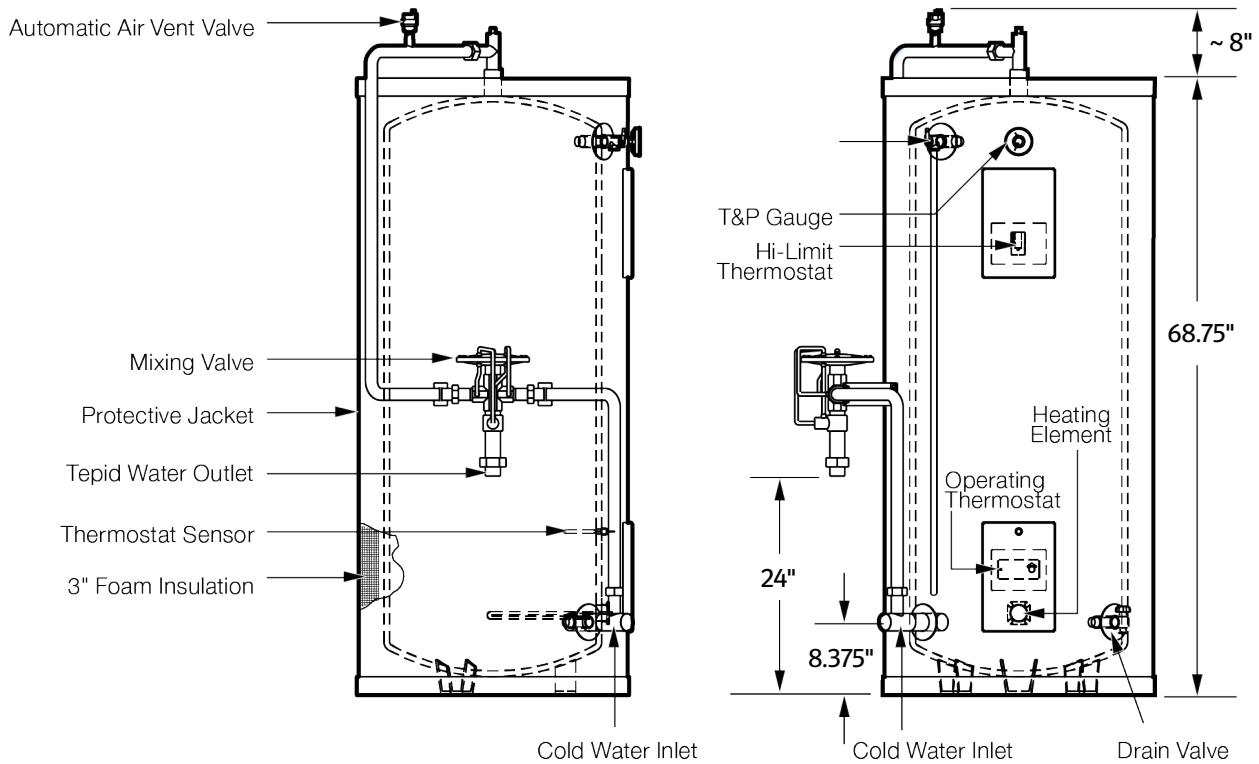
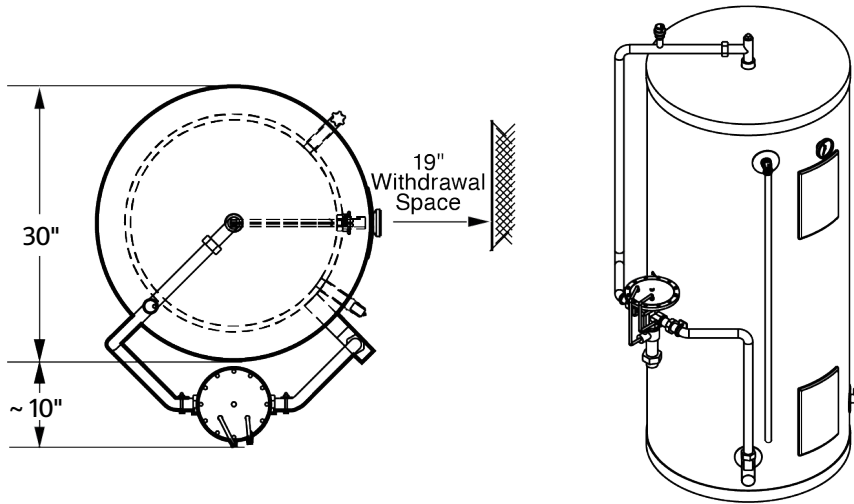

**Note:** Alternate storage capacities are available for smaller or larger requirements. Please consult factory for sizing requirements.

All information is subject to change without notice. Consult factory for submittal drawings.

## kW and Amperage Selection Chart

**120 Gallon** (Amperage shown in chart below indicates available models)

kW	Recovery (100°F dT)	1 Phase Voltages					3 Phase Voltages				
		120	208	240	277	480	208	240	380	480	575
0.5	2	4	2								
1	4		5	4	4						
1.5	6	13	7	6	5						
2	8	17	10	8	7	4	6				
2.5	10	21	12	10	9	5					
3	12		14	13		6	8	7	5		
3.5	14		17	15	13	7					
4	16		19	17	14	8	11	10	6	5	
4.5	18		22	19	16	9					
5	21		24	21	18	10	14	12	8	6	
6	25		29	25	22	13	17	14			6
7	29				25	15			11	8	
8	33		38	33	29	17	22	19	12	10	8
9	37		43				25				
10	41			42		21		24	15		10
11	45		53		40		31			13	
12	49			50				29	18		
13	53					27					13
14	57		67	58	51		39	34		17	
15	62					31					
16	66				58				24	19	
17	70		82				47				
19	78			79	69			46	29	23	
23	94			96				55			

**Note:** Standard tanks only, additional kW available.

### Formulas to Solve For:

#### To Solve for Tepid Water Pressure Drop:

$\frac{\text{GPM}^2}{\text{Cv}^2} = \Delta P$  **Example:** Determine pressure drop across Hubbell model EMV with a 20 GP flow

$$\frac{20^2}{10^2} = \frac{400}{100} = 4 \text{ psi pressure drop}$$

**Note:** The Hubbell EMV Valve maintains the same pressure drop even when the valve is in cold water bypass mode

#### To Solve for the Percentage of Hot Water to Final Mixed Water:

$$\frac{M-C}{H-C} = \% \text{ of hot to mixed water}$$

**Example:** Determine the percent of 170°F hot water required for a mixed temperature of 85°F when cold water is 50°F

$$\frac{85-50}{170-50} = \frac{35}{120} = 29\% \quad \text{Therefore, 29\% of the mixed 85°F water stream must be 170°F}$$

M = Mixed water temperature  
C = Cold water temperature  
H = Hot water temperature

All information is subject to change without notice. Consult factory for submittal drawings.

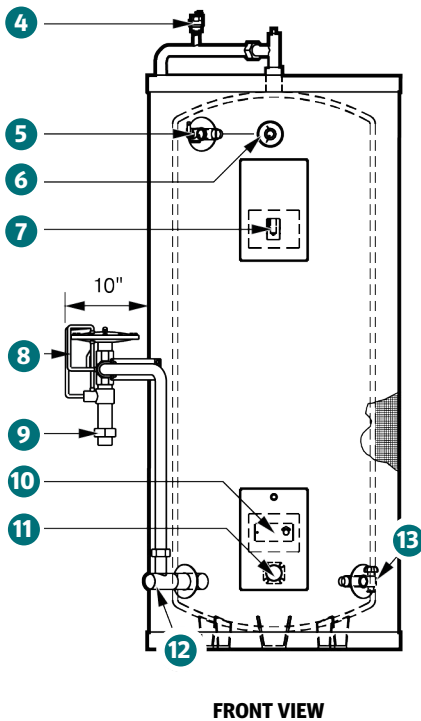
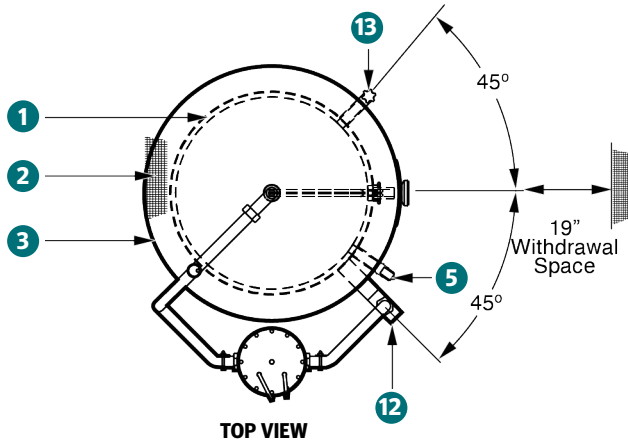
**Diagram Key**

PC Number	Description
1	HydraStone Cement Lined Tank
2	3" Polyurethane Foam Insulation
3	Corrosion Resistant Jacket
4	Air Vent Valve
5	Relief Valve Connection
6	Dial Temperature Pressure Gauge
7	Hi-Limit Thermostat
8	Mixing Valve
9	Tepid Water Outlet
10	Tank Operating Thermostat
11	Heating Element
12	Cold Water Inlet
13	Drain Connection

**Tepid Water Delivery**

\_\_\_\_\_ GPM for \_\_\_\_\_ min @ 85°F

**Recovery Rating**

GPH from \_\_\_\_\_ to \_\_\_\_\_ ( \_\_\_\_\_ °F ΔT )

**Important Notes:**

1. Storage tank Rate for 150 psi WP.
2. ASME rated T&P relief valve factory installed and piped to 12" from floor.
3. All Electrical controls are factory wired and tested.
4. Mixing valve (pc. 8) is factory set, calibrated and tested to deliver 85°F water.



## Suretemp EMV Model Number Designation

MODEL	MODEL NUMBER	STYLE	TEPID WATER TEMPERATURE**	STANDARD kW RATINGS	TANK TYPE	VOLTAGE / PHASE	ALTERNATE HEATING SOURCE	OPTIONAL EQUIPMENT
<b>EMV</b>	120*	<i>Leave blank for standard</i> <b>A = ASME</b>	85°F (Standard set temperature) Optional 75°F	0.5–23 <i>See chart on page 6 for available options</i>	<b>SL</b> = HydraStone cement lined tank <b>SS</b> = Stainless steel 316L	<b>A</b> = 120/1 <b>RS</b> = 208/1 <b>S</b> = 240/1 <b>W</b> = 277/1 <b>T4S</b> = 480/1  <b>Balanced 3Φ only</b> <b>R</b> = 208/3 <b>T</b> = 240/3 <b>T4</b> = 480/3 <b>T6</b> = 600/3	<b>GS</b> = Gas <b>ST</b> = Steam <b>BW</b> = Hydronic	Write/type optional equipment code in the gray box below in alphabetical order. For multiple options separate codes with a dash (-).

EMV

### Important Notes

\*Optional storage capacities available, consult factory.

\*\*Mixing valves are not field adjustable.

### Example: EMV120-85-3SLS-V20

Suretemp EMV emergency tepid water delivery system with a storage capacity of 119 gallons, 85°F set point of the mixing valve and a 3 kW rating. Storage tank is lined with HydraStone cement and operates at 240 volts single-phase power, with optional integrally welded seismic attachment points.

### Available Accessories

(Fill out form below to order accessories.)

**10-year Warranty:** 10-year non pro-rated tank warranty, specify part number "VESSEL WARRANTY"

#### Accessories Name

Part #

## Optional Equipment Note: Optional equipment must be called out in the written specifications, use the codes below.

### Controller

- C55** Low temperature alarm dry contacts (alarm temperature is adjustable from 30-110°F).
- C56** Hi temperature alarm dry contacts (alarm temperature is the hi-limit set point, which is adjustable from 100-240°F).
- C57** Flow alarm indication dry contact to signal that there is tepid water flow (minimum flow rate to activate 7GPM).

### General

- G9** Explosion resistant construction for installation in a hazardous location. Standard is Class 1, Division 2, Group BT5. If application requires other, please specify Class, Division, Group, and temperature rating required.
- G21** NEMA 4 X enclosure provides added protection for the mixing valve in outdoor environments.

- G25** Outdoor weather package includes a 304 stainless steel outer protective jacket, weather resistant NEMA 4X electrical housing, NEMA 4X enclosure surrounding the mixing valve and 6" high 304 stainless steel tank legs to raise the entire unit off the floor.
- G35** All hot and cold-water piping on the heater package is to be heat traced from the factory for freeze protection, to include an insulation jacket for the thermostatic mixing valve. Please note that all external piping to the heater needs to be heat traced in the field.

### Vessel

- V20** Integrally welded seismic attachment points.

**Please note:** Optional equipment may impact overall dimensions and weight. Please request submittal drawing from factory.