



## Explosion Resistant Water Heater

**10-119 gallon capacity standard,  
up to 10,000 gallon available,  
1.5-58 kW, single or three phase**

**Built for safe operation in hazardous locations**

**UL and CSA listed housing rated for operation  
in Class I, Division 1 & 2, Groups B, C, & D  
(Class I, Zones 1 & 2, Groups II B&H, II B & II A)  
Class II, Division 1 & 2, Groups E, F, & G  
(Zones 21 & 22, Groups III C & III B)**

**HydraStone cement lining provides  
long tank life**

- Copper-silicon alloy tappings and high impact composite jacket cannot rust or corrode
- All controls factory selected and wired for efficient installation and operation
- Ready for electrical and plumbing service connections

### Applications

Refineries, drilling platforms, paper and pulp mills, industrial facilities, and much more.



RESISTANCE SERIES

ER

### A long-lasting water heater for your hazardous location

The Hubbell Resistance ER (explosion resistant) water heater is specifically made for applications in hazardous locations. Operating controls are housed within a heavy-duty explosion resistant electrical enclosure to ensure safe operation. The electrical conduit is factory sealed to meet specific class and division code. The water heater also includes an explosion resistant heating element, and the entire unit is sealed and covered for locations with high hazard vapors or dust.

### Over 100 years of water heating expertise

Hubbell water heaters are the right choice for your commercial and industrial applications. We have water heating solutions for most energy sources with storage capacities from 6–10,000 gallons – all designed, engineered, and manufactured for reliability and longevity coupled with unparalleled support and service.

ASME option available.



## The Difference: HydraStone Cement Lining

**Cement lined tanks offer significant longevity, trouble-free operation and a lower lifetime cost.**

**The type of protective lining** is the single most important feature when determining the quality of any water heater. The ability of a lining to protect the steel tank is primarily based on its thickness and complete coverage of all steel surfaces.

**A glass lined tank uses only .005 inches of glass** which does not cover all internal surfaces. To compensate, all glass lined tanks require a sacrificial anode rod which must be periodically inspected and replaced.

**Our tanks are lined with a minimum of .5 inches of high density HydraStone cement – 100 times thicker than glass lining.** Full coverage is achieved by injecting the precise amount of HydraStone cement into each tank and then centrifugally spinning it at 250 RPM to ensure complete and uniform coverage. This process provides maximum protection from the corrosive effects of hot water. Additionally, cement lined tanks do not require a sacrificial anode, eliminating periodic inspections and replacement costs associated with glass lined tanks.

**Our water heater tanks are constructed with solid non-ferrous copper-silicon tank tappings** which are impervious to the corrosive effects of hot water. Glass-lined tanks have regular steel tappings which are vulnerable to corrosion.

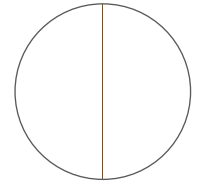
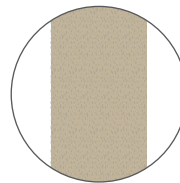
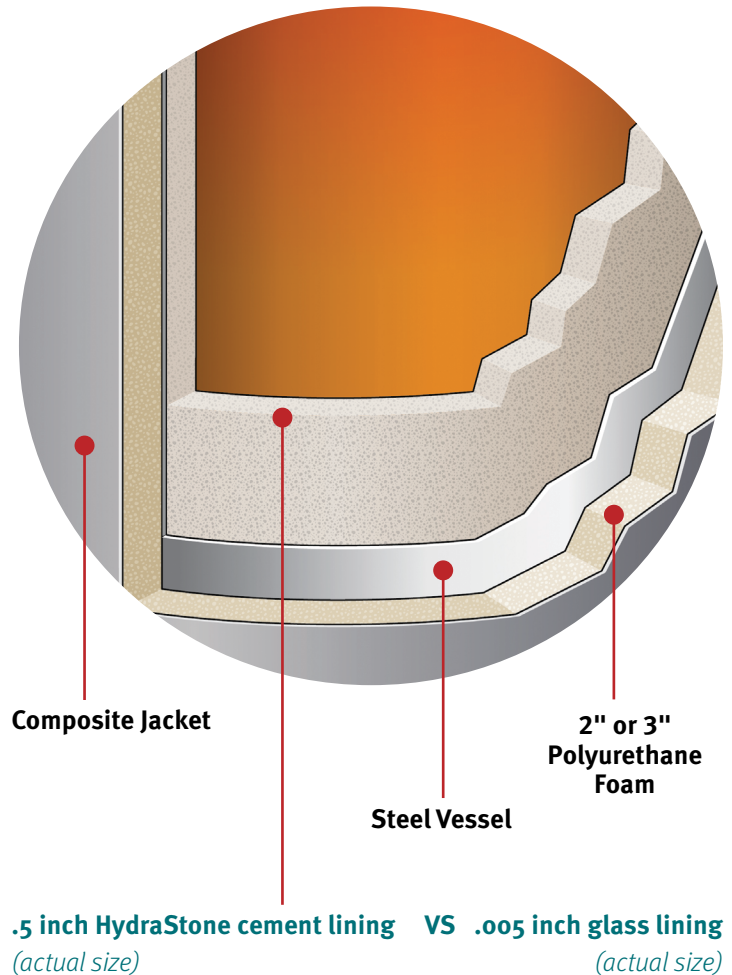

## Heater Specifications

<b>Tank</b>	HydraStone Cement Lined Steel
<b>Capacities</b>	10–119 Gallons Standard up to 10,000 Gallons available
<b>Orientation</b>	Vertical or Horizontal
<b>Voltages</b>	120–600 V
<b>Phase</b>	1 or 3 Phase
<b>Inlet Size</b>	¾" Female NPT
<b>Outlet Size</b>	¾" Male NPT
<b>Drain Size</b>	¾" GHT
<b>Relief Valve Opening</b>	¾" Female NPT
<b>Relief Valve Type</b>	T&P, 210°F, 150 psi
<b>Thermostat Type</b>	Adjustable
<b>Thermostat Range</b>	110–170°F
<b>Hi-Limit</b>	190°F
<b>Design Pressure</b>	150 psi WP, 300 psi TP
<b>Elements</b>	High Quality Immersion Electric
<b>Insulation</b>	2" or 3" Polyurethane Foam
<b>Tank Warranty</b>	3 Years Non-Pro-Rated
<b>Electrical Warranty</b>	1 Year
<b>Jacket</b>	High Impact Colorized Composite
<b>Finish</b>	White and Black

**Note:** For alternative voltages, kW sizes and/or storage capacities above 119 gallons please consult factory.

## Standard Features

### Up to 119 gallon

- Hazardous location electrical enclosure rated for operation in a
  - Class I, Division 1 & 2, Groups B, C, & D (Class I, Zones 1 & 2, Groups II B & H, II B & II A)
  - Class II, Division 1 & 2, Groups E, F, & G (Zones 21 & 22, Groups III C & III B) listed for hazardous area locations
- Heavy Duty ½" thick HydraStone cement lined storage tank for long service life
- Non-ferrous solid copper-silicon tank openings
- Built-in heat trap to improve operating efficiency
- High-quality long-lasting immersion heating elements
- Magnetic contactor (3 Φ only)
- Adjustable temperature controller (110–170°F)
- 2" Polyurethane foam insulation for minimum standby heat loss
- High impact colorized composite protective jacket
- ASME/CSA rated combination temperature and pressure relief valve set at 150 psi, 210°F
- ¾" Male NPT inlet and outlet connections (except 45 and 54kW)
- Units 45 kW and over are supplied with 1-1/2" Male NPT inlet/outlet connections and immersion hi-limit.



All information is subject to change without notice. Consult factory for submittal drawings.

## Dimensions

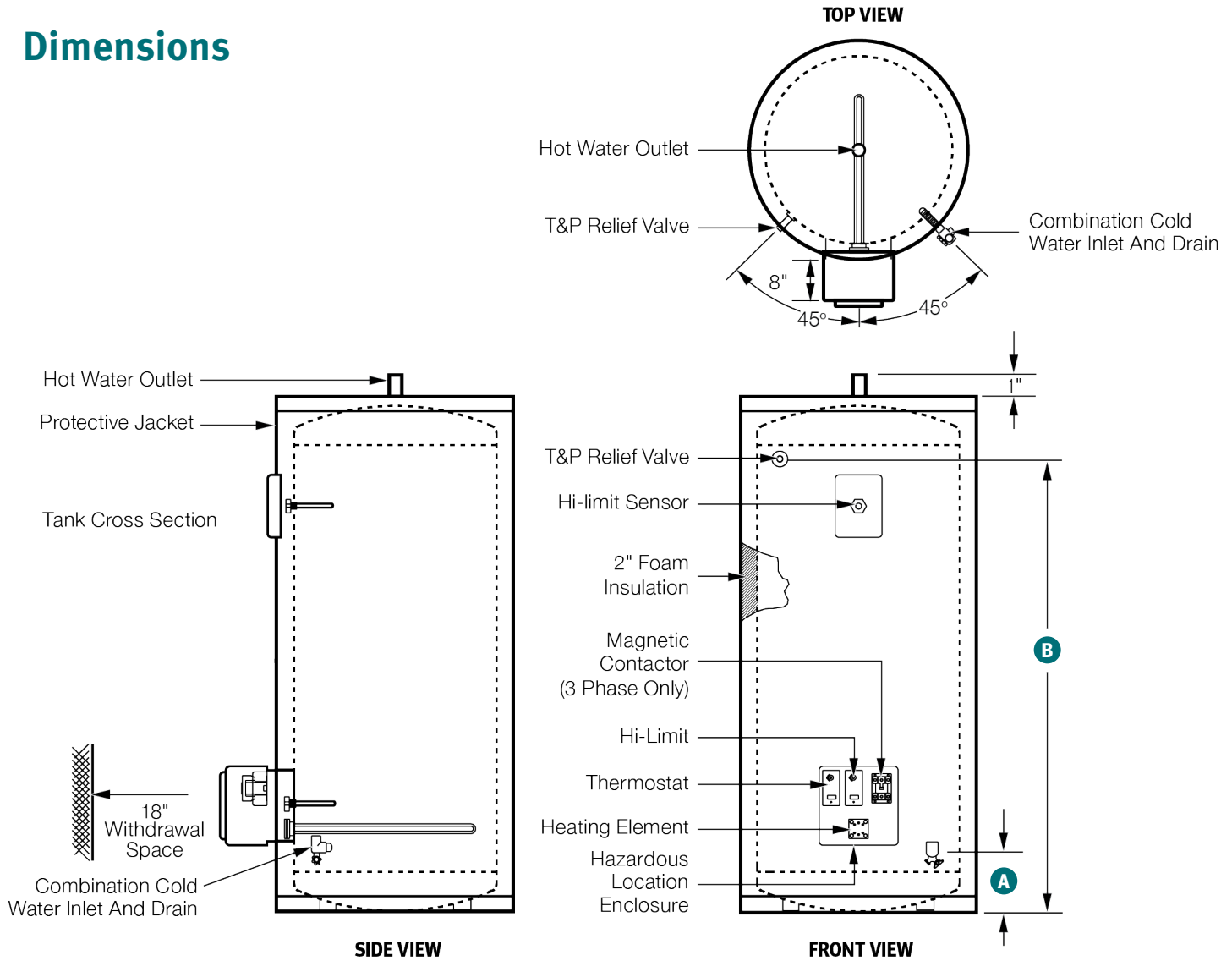

## Resistance ER Dimensional Data

Storage Capacity (Gal)	Dimensions (Inches)				Shipping Weight (lbs.)
	Overall Diameter	Overall Height	Inlet "A"	T&P Valve "B"	
10	16	21	7	15	160
19	16	33	7	27	200
30	16	41.5	7	34	230
40	16	58.75	7	51	280
50	19	51	7	43	295
65	19	48	8	40	360
80	22	58	8	51	395
100	22	69.5	8	62	425
119	24	69.25	8	62	475

**Note:** For alternative voltages, kW sizes and/or storage capacities above 119 gallons please consult factory.

All information is subject to change without notice. Consult factory for submittal drawings.

## kW and Amperage Selection Charts

### 10 & 20 Gallon (2" Insulation), 30, 40, & 50 Gallon (3" Insulation)

(Amperage shown in chart below indicates available models)

kW	1 Phase Voltages					3 Phase Voltages				Recovery (GPH)
	120	208	240	277	480	208	240	277	480	
1.5	13									6
2		10	8	7	4					8
2.5		12	10	9	5					10
3		14	13	11	6	8	7	6	4	12
3.5		17	15	13	7					14
4		19	17	14	8	11	10	8	5	16
4.5		22	19	16	9					18
5		24	21	18	10	14	12	10	6	21
5.5		26	23	20	11					23
6		29	25	22	13	17	14	13	7	25
8						22	19	17	10	33
10						28	24	21	12	41

\* 10 and 20 gallon are 2" Insulation

### 65, 80, 100, and 120 Gallon (2" Insulation)

(Amperage shown in chart below indicates available models)

kW	3 Phase Voltages				Recovery (GPH)
	208	240	277	480	
3	8	7	6	4	12
4	11	10	8	5	16
5	14	12	10	6	21
6	17	14	13	7	25
8	22	19	17	10	33
10	28	24	21	12	41
12	33	29	25	14	49
12.5	35	30	26	15	51
15	42	36	31	18	62
20	56	48	42	24	82
30	83	72	63	36	123
35	97	84	73	42	144
40	111	96	83	48	164
45	125	108	94	54	185
54	150	130	113	65	221
58	161	140	121	70	238

#### Notes

1. Recovery calculated is at 100 °F ΔT Rise
2. Units 45 kW and over are supplied with 1-1/2" Male NPT inlet/outlet connections and immersion hi-limit.
3. For alternative voltages, including 220, 415, 440, 460 volt, please consult factory for available kW selection.

#### Formulas to Solve For:

##### kW Required

$$\text{GPH} \times \text{_____} \text{ } ^\circ\text{F } \Delta\text{T} \times 0.00244 = \text{kW}$$

##### Temperature Rise

$$\text{kW} \times 410 \div \text{GPH} = \text{_____} \text{ } ^\circ\text{F Rise}$$

##### Recovery

$$\text{kW} \times 410 \div \text{_____} \text{ } ^\circ\text{F } \Delta\text{T Rise} = \text{GPH}$$

##### Amperage

$$\text{1 PHASE: } \text{kW} \times 1000 \div \text{Voltage} = \text{Amps } 1\phi$$

$$\text{3 PHASE: } \text{kW} \times 1000 \div \text{Voltage} \div 1.73 = \text{Amps } 3\phi$$

**Notes:** 1kW will heat 4.1 GPH at a 100°F Rise

All information is subject to change without notice.

Consult factory for submittal drawings.

## Resistance ER Model Number Designation

MODEL	MODEL NUMBER*	HORIZONTAL	kW SELECTION	TANK	VOLTAGE / PHASE	OPTIONAL EQUIPMENT
ER	10	<i>Leave blank for standard</i> <b>A = ASME</b>	1.5 – 58**	<b>SL</b> = HydraStone cement lined	<b>A</b> = 120-1 <b>RS</b> = 208-1 <b>S</b> = 240-1 <b>W</b> = 277-1 <b>T4S</b> = 480-1 <b>R</b> = 208-3 <b>T</b> = 240-3 <b>T3</b> = 380-3 <b>T7</b> = 415-3 <b>T5</b> = 440-3 <b>T4</b> = 480-3 <b>T6</b> = 600-3	Write/type optional equipment code in the gray box below in alphabetical order. For multiple options separate codes with a dash (-)
	20			<b>CN</b> = Copper-Nickel		
	30			<b>SS</b> = Stainless steel 316L		
	40					
	50					
	65					
	80					
	100					
120						

ER

\* For larger vessel capacity, consult factory.

\*\* Higher kW available. Consult factory.

### Example: ER10-1.5SLA-G25

Is a hazardous location Resistance ER water heater with 10 gallons of storage and 1.5 kW heating element. It is a cement lined steel vessel and has an electrical rating of 120 volt, single phase, 60 Hz, with optional outdoor weather package.

**Note:** For alternative voltages, kW sizes and/or storage capacities above 119 gallons please consult factory.

## Optional Equipment *Optional equipment must be called out in the written specifications, use the codes below.*

### Controller

**C5** Low water cut-off

### General

**G25** Outdoor Weather Package (304 SS Jacket and 6" Legs, NEMA 4X Electrical Housing)

### Vessel

**V3** 3" Polyurethane foam insulation

**V10** 1-½" Male NPT brass inlet and outlet water connections

**V20** Integrally welded seismic attachment points

**Please note:** Optional equipment may impact overall dimensions and weight. Please request submittal drawing from factory.

## Available Accessories *(Fill out form below to order accessories.)*

**10-year Warranty:** 10-year non pro-rated tank warranty, specify part number "VESSEL WARRANTY"

Accessories Name

Part #