



Commercial Condensing Gas Water Heater

65–119 gallons, up to 110,000 BTU/HR 94% thermal efficiency

High efficiency fully modulating and removable 316L SS heat exchanger

94% thermal efficiency

Available in 55,000 and 110,000 BTU/HR input

- HydraStone™ cement lined tank
- Digital temperature controller
- 7-year non-prorated tank warranty
- 5-year non-prorated heat exchanger warranty

Applications

Hotels, restaurants, medical centers, schools, apartments, athletic clubs, stadiums, office buildings, laundromats, shopping centers, and more.



PRIME SERIES
GSE

Industry's only cement lined condensing gas storage water heater

The Hubbell Prime GSE condensing gas storage water heater features a fully integrated burner and field removable 316L SS heat exchanger. The modular heat exchanger allows for easy cleaning and serviceability, which ultimately provides maximum longevity and sustained peak performance. High efficiency polyurethane foam insulation reduces standby heat loss, while the modulating air/gas combustion blower improves combustion efficiency and reduces short-cycling. The Prime has a thermal efficiency rating of 94% and is available in storage capacities ranging from 40–119 gallons.

ASME option available.



The Difference: HydraStone™ Cement Lining

Cement lined tanks offer significant longevity, trouble-free operation and a lower lifetime cost.

The type of protective lining is the single most important feature when determining the quality of any water heater. The ability of a lining to protect the steel tank is primarily based on its thickness and complete coverage of all steel surfaces.

A glass lined tank uses only 5/1000 inches of glass (the thickness of a sheet of paper) which does not cover all internal surfaces. To compensate, all glass lined tanks require a sacrificial anode rod which must be periodically inspected and replaced.

Our tanks are lined with a minimum of 1/2 inches of high density HydraStone cement – 100 times thicker than glass lining. Full coverage is achieved by injecting the precise amount of HydraStone cement into each tank and then centrifugally spinning it at 250 RPM to ensure complete and uniform coverage. This process provides maximum protection from the corrosive effects of hot water. Additionally, cement lined tanks do not require a sacrificial anode, eliminating periodic inspections and replacement costs associated with glass lined tanks.

Our water heater tanks are constructed with solid non-ferrous stainless steel tank tappings which are impervious to the corrosive effects of hot water. Glass-lined tanks have steel tappings which are vulnerable to corrosion.

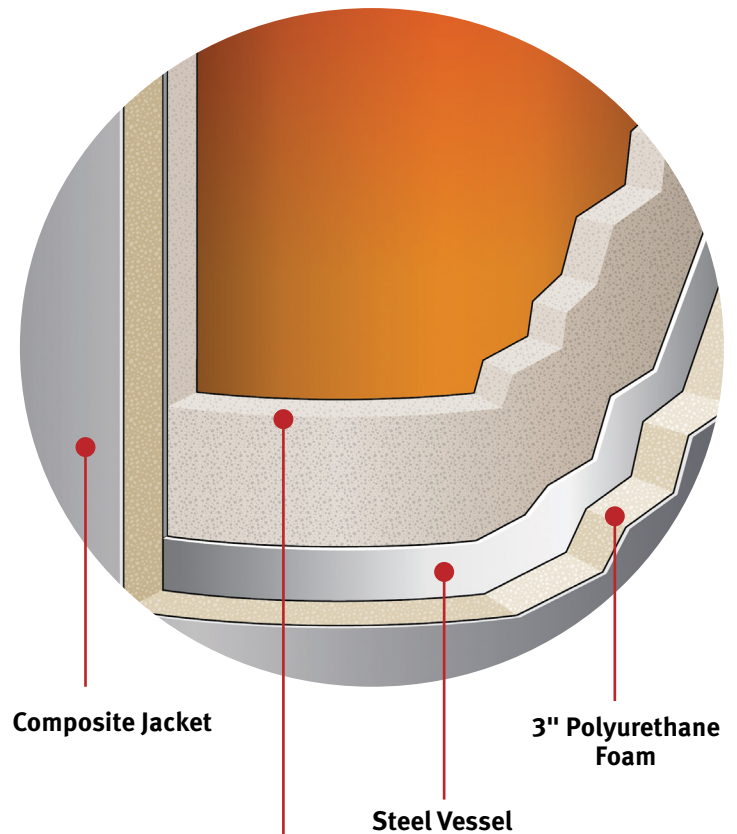

1/2 inch HydraStone™ cement lining

VS

5/1000 inch glass lining

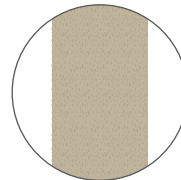

(actual size)

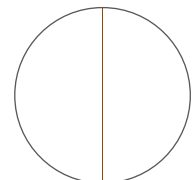

(actual size)

The Hubbell Prime GSE Advantage

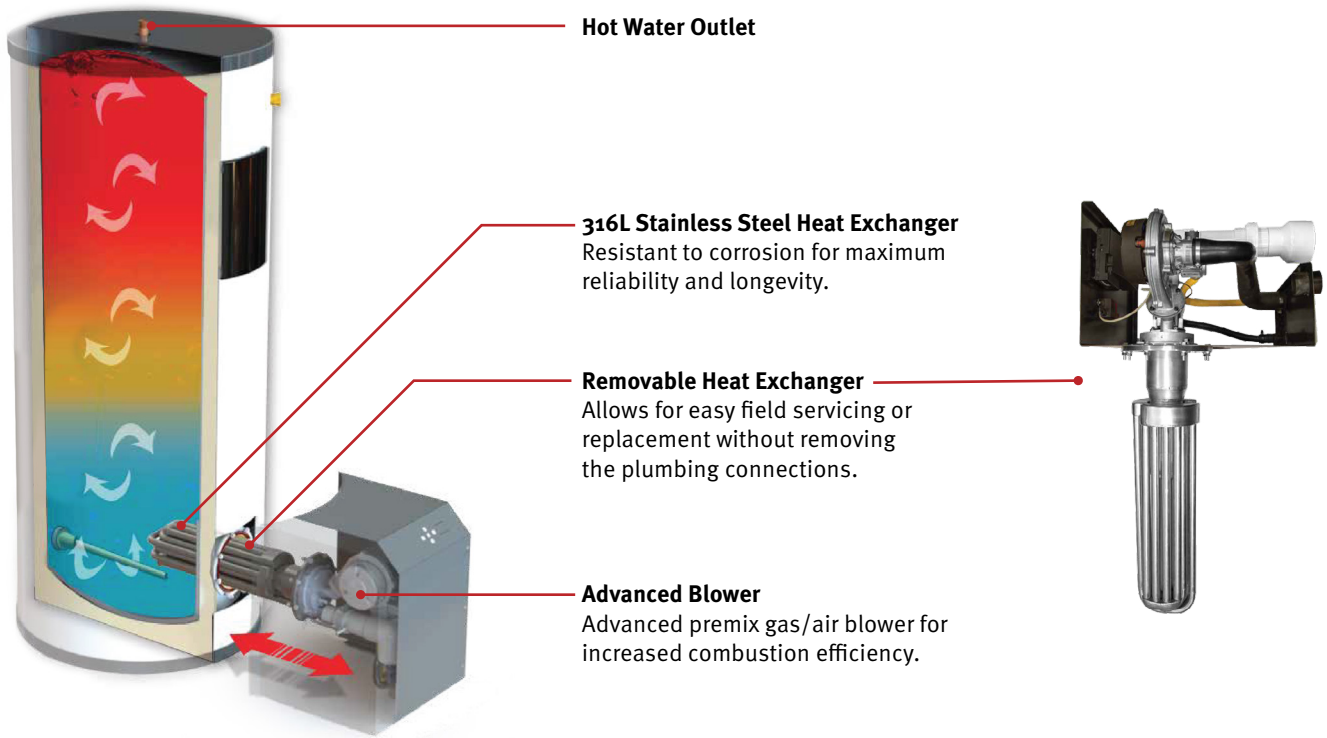

The Hubbell Prime GSE heat exchanger versus other heat exchangers

Hubbell Prime GSE Heat Exchanger	Other Heat Exchangers
Modular construction	Permanently welded to outer vessel
Fully removable heat exchanger	Not removable
Easily serviced in the field	Not serviceable
Heat exchanger can be replaced without water heater removal or replacement	Heat exchanger failure requires water heater replacement
Repairable	Not repairable
Cleaning is quick and easy	Cleaning is difficult, time-consuming, and costly
Minimal welded area reduces the probability of failure	Significant welded surface area increases the probability of failure

Dimensions GSE55-C

Sample dimensions are for a GSE55-C which includes 3/4" Inlet/Outlet. GSE55-C-1.5 with 1-1/2" Inlet/Outlet is also available in 65, 80, 100 and 119 gallon capacities.

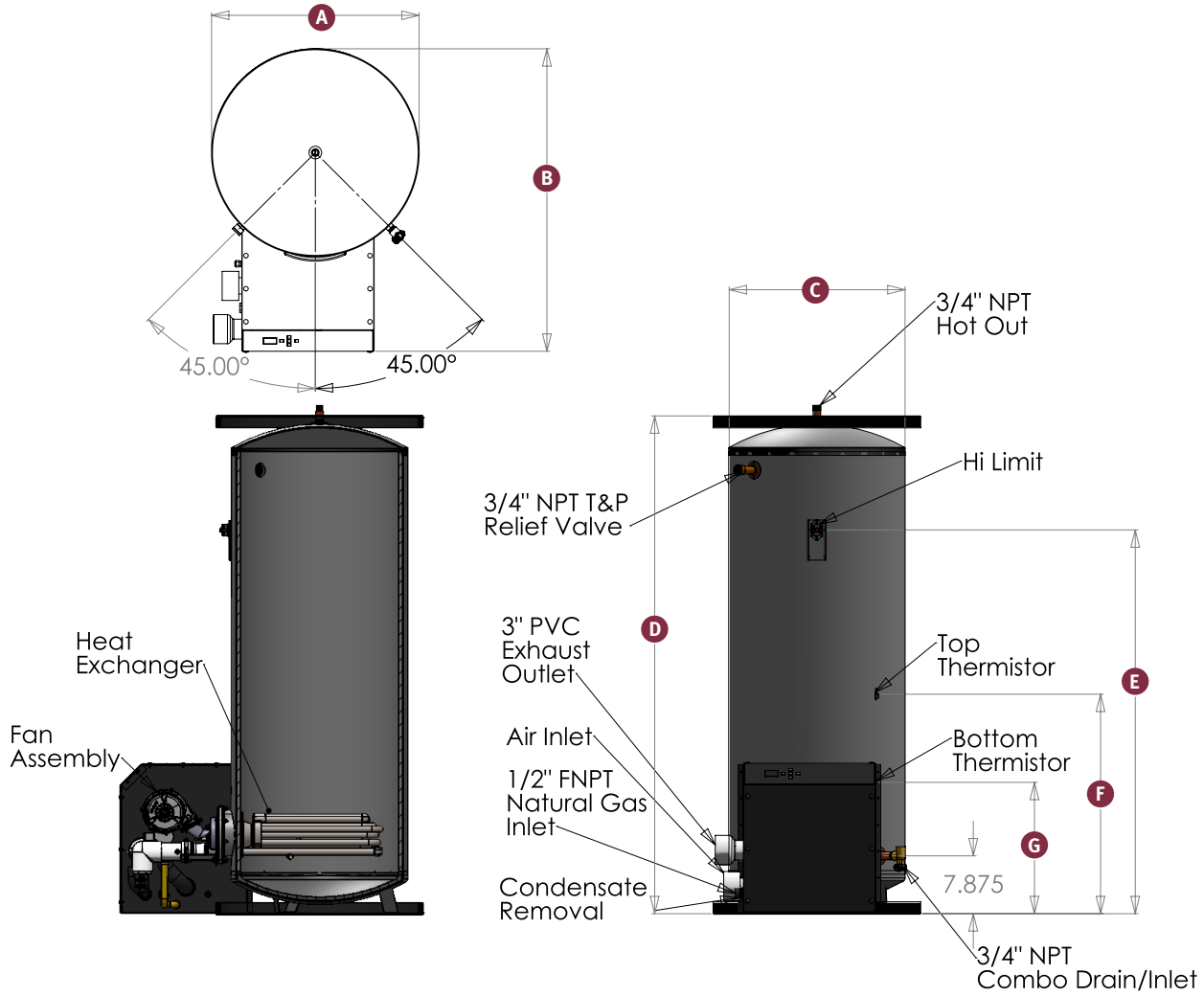

Base Model	Storage Capacity (Gallons)	Overall Dimensions (Inches)							Shipping Weight
		A	B	C	D	E	F	G	
GSE55-C-65SL	65	26	38.625	22	46.25	36.75	25.75	13.75	350
GSE55-C-80SL	80	26	38.625	22	57.25	45.25	25.75	13.75	430
GSE55-C-100SL	100	26	38.625	22	67.50	52.75	25.75	13.75	490
GSE55-C-120SL	119	28	40.625	24	67.75	52.75	29	17.00	520

All information is subject to change without notice. Consult factory for submittal drawings.

Dimensions GSE110-C

Sample dimensions are for a GSE110-C which includes 3/4" Inlet/Outlet. GSE110-C-1.5 with 1-1/2" Inlet/Outlet is also available in 65, 80, 100 and 119 gallon capacities.

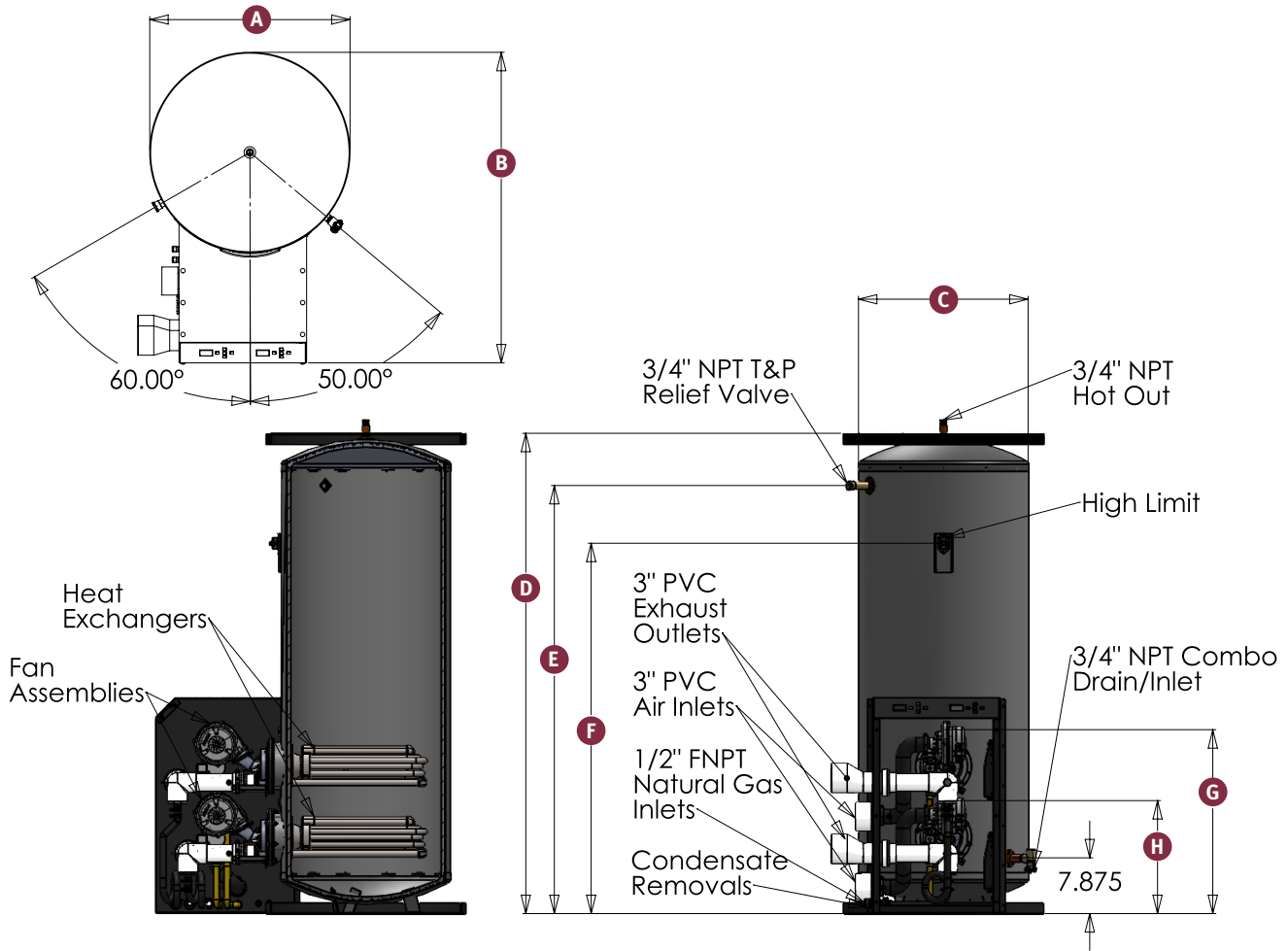

Base Model	Storage Capacity (Gallons)	Overall Dimensions (Inches)								Shipping Weight
		A	B	C	D	E	F	G	H	
GSE110-C-65SL	65	26	38.625	22	46.25	39.375	36.75	24.75	14.75	415
GSE110-C-80SL	80	26	38.625	22	57.25	49.875	45.25	24.75	14.75	495
GSE110-C-100SL	100	26	40.25	22	67.50	60.375	52.75	24.75	14.75	555
GSE110-C-120SL	119	28	41.25	24	67.75	60.375	52.75	24.75	14.75	585

All information is subject to change without notice. Consult factory for submittal drawings.

Performance

Base Model	BTU/Hour Input	Continuous Recovery 40-140°F (Gallons)	First Hour Recovery 40-140°F (GPH)
GSE55-C-65SL	55,000	62	102
GSE55-C-80SL	55,000	62	132
GSE55-C-100SL	55,000	62	153
GSE55-C-120SL	55,000	62	171
GSE110-C-65SL	110,000	124	164
GSE110-C-80SL	110,000	124	197
GSE110-C-100SL	110,000	124	218
GSE110-C-120SL	110,000	124	236

Standard Equipment

- 1/2" thick HydraStone cement lining
- 316L Stainless steel heat exchanger
- Digital temperature controller
- ASME temperature and pressure relief valve set at 150 PSI and 210°F
- 2" thick Polyurethane Foam insulation meets or exceeds the requirements of ANSI/ASHRAE/IESNA 90.1
- High impact non-corroding colored composite protective jacket
- Cold water inlet diffuser with drain valve



