



Deionized (RO/DI) ASME Water Heater

For heating ultra pure and mildly corrosive water. Point-of-use heater up to 88 kW in single or three phase voltages

Type 316L stainless steel construction resists corrosion

Heating elements are all 316L SS to ensure long operating life

Packaged with all electrical operating controls for trouble-free installation, service and operation

Small reserve capacity lowers peak power demand and reduces operating costs

- Easy to service – when replacing a part no other part needs to be removed
- High grade construction materials provide maximum longevity
- Most models are easily upgradable to handle future expansion
- Full range of sizes available to meet your exact heating needs

Applications

Industrial finishing and cleaning systems for electronic and fabricated metal parts such as PC boards, microchips, capacitors, metal parts, jewelry, aerospace quality bearings, cosmetic and drug packaging systems, glass products, ultrasonic cleaning systems, food processing systems, water purification and RO systems.



ULTRAPURE SERIES

A reliable deionized water heater

The Hubbell UltraPure HD is a dependable water heater for continuous, cyclical, or variable flow systems in a wide range of applications that require DI/RO water. The UltraPure HD has a 316L stainless steel ASME stamped pressure vessel that resists the corrosive effects of hot deionized water and provides maximum longevity. Only the highest quality materials and components are used to ensure reliable operation in even the most demanding application. The UltraPure HD is ready for immediate installation and service and all electrical operating controls are factory selected, sized and wired.

Over 100 years of water heating expertise

Hubbell water heaters are the right choice for your commercial and industrial applications. We have water heating solutions for most energy sources with storage capacities from 1–10,000 gallons – all designed, engineered, and manufactured for reliability and longevity coupled with unparalleled support and service.



Why Install A Hubbell Ultrapure HD RO/DI Water Heater?

Reliability

The Hubbell HD tank is all 316L stainless steel construction and engineered, constructed, and stamped in strict conformance to ASME Section VIII.

Lower Operating Costs

Environmentally friendly CFC/HCFC free closed cell foam insulation minimizes stand-by heat loss. This high-quality insulation reduces heat loss by more than half when compared to fiberglass type insulation.

Reduced service and maintenance costs

- The digital display controller provides exact set point temperature (there is no calibration necessary), as well as visual error indication.
- Controller is adjustable from 32–194°F (0°–90°C) with adjustable temperature differential.
- Includes a float type low water cut off to prevent the heating elements from dry firing.
- All components are removable without disturbing any other component, making maintenance easy.
- The heating elements and sensing probe are straight thread screw types that utilize an O-ring to minimize leakage.

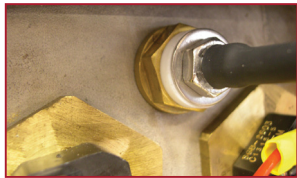

All sensing functions are integrated into ONE probe which can be replaced without draining the tank

Brushed stainless steel exterior increases life and looks great

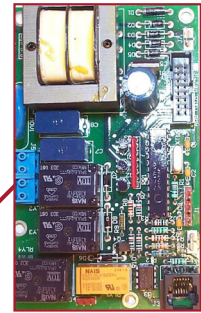

Electronic control module integrates all control functions into one component

Magnetic contactor provides load switching

Resettable circuit breakers (on units over 120 amps) replace one-shot fuses

Closed cell foam insulation lowers operating costs

Single point power connection

Leak detection system notifies the user if water is detected inside the control area

ASME stamped all stainless steel tank for extended life

Screw plug elements simplify service

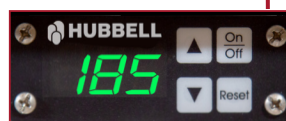
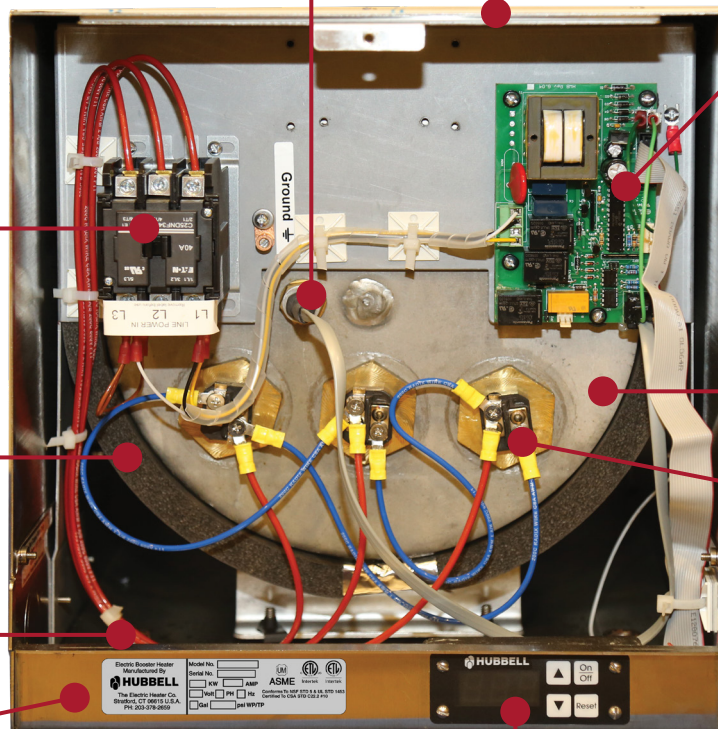

Digital display provides visual set point and fault conditions. Operator controls are easily accessible including ON/OFF, reset, and temperature adjustment

Heater Specifications

Vessel	316L stainless steel
Storage Capacity	6 or 16 gallons
Voltage	120–600 volt
Phase	1Φ or 3Φ
Connections (1.5-58kW)	
Material	316L stainless steel
Inlet	¾" Male NPT
Outlet	¾" Male NPT
Relief Valve	¾" Female NPT
Connections (64-88kW)	Available for HD16 only
Material	316L stainless steel
Inlet	1-½" Male NPT
Outlet	1-½" Male NPT
Relief Valve	1" Female NPT
Temperature Controller	
Type	Solid state
Style	Immersion
Range	32–194°F (0–90°C)
Hi-Limit	
Type	Solid state
Style	Immersion
Reset	Manual
Range	205°F (fixed)

Pressure Drop	HD6	HD16 (¾")	HD16 (1-½")
5 GPM	0.11 psi	0.15 psi	<1psi
10 GPM	0.43 psi	0.58 psi	<1psi
25 GPM	2.6 psi	3.6 psi	<1psi
50 GPM	10.5 psi	14.4 psi	<1psi

Heating Element	
Type	Screw plug with Viton O-ring
Style	Tubular
Sheathing	316L stainless steel passivated and electropolished
Controller	
Degrees	°F or °C (default °F)
Differential	1°–20° (default 2°)
Display	Shows set point or actual temperature (default set point)
Low Water Sensing	On or Off (Default: On)
Low Water Reset	Manual or Automatic (Default: Automatic)
Staging	Up to 3 stages
Magnetic Contactor	
Type	Definite purpose
Control Circuit	208/240 volt
Internal Wiring	Tefzel 750 200°C
Digital Display	3-digit 7 segment LED display
Fault Indicators	Hi-temperature No probe Leak detection
Low Water Type	Float 316L stainless steel
Design WP	150 psi
Design TP	225 psi
Relief Valve	
Approvals	ASME/CSA
Temperature	210°F
Pressure	150 psi
Material	316L stainless steel
Insulation	CFC/HCFC free Closed cell foam
Outer Jacket	316L stainless steel
Warranty	
Vessel	3 years
Electrical	1 year

UltraPure HD and HDF kW and Amperage Selection Charts

6 Gallon (Amperage shown in chart below indicates available models)

kW	1 Phase Voltages			3 Phase Voltages			
	120	208	240	208	240	480	600
1.5	13						
2.5	21						
4		19	17				
6		29	25	17	14	7	6
7		34	29	19	17	8	7
9		43	38	25	22	11	9
10		48		28			
12		58	50	33	29	14	12
13.5		65	56	38	33	16	13
18		87	75	50	43	22	17
24		115	100	67	58	29	23
27		130	113	75	65	33	26
36		173	150	100	87	43	35
40.5		195		113			39
45			188	125	108	54	
54				150	130	65	52
58.5				163	141	70	56

Note: The 6, 7 and 9kW models in 208 and 240 volt can be field converted from either 1 phase to 3 phase or from 3 phase to 1 phase.

HDF 6 Gallon (Clean-in-Place, see page 8) (Amperage shown in chart below indicates available models)

kW	1 Phase Voltages			3 Phase Voltages			
	120	208	240	208	240	480	600
1.5	13						
2.5	21						
4		19	17				
6		29	25	17	14	7	6
7		34	29	19	17	8	7
9		43	38	25	22	11	9
10		48		28			
12		58	50	33	29	14	12
13.5		65	56	38	33	16	13
18		87	75	50	43	22	17
24		115	100	67	58	29	23
27		130	113	75	65	33	26
36		173	150	100	87	43	35
40.5		195		113			39
45			188	125	108	54	
54				150	130	65	52
58.5				163	141	70	56

Note: Dimensionally all HDF6 models are identical to model HD6 (24 – 58.5 kW). See page 6 for dimensional details.

All information is subject to change without notice. Consult factory for submittal drawings.

kW and Amperage Selection Charts

16 Gallon with ¾" inlet and outlet (1.5 to 58.5kW)

(Amperage shown in chart below indicates available models)

kW	1 Phase Voltages				3 Phase Voltages			
	120	208	240	480	208	240	480	600
1.5	13							
2.5	21			8				
4		19	17					
6		29	25		17	14	7	6
7		34	29		19	17		7
9		43	38		25	22	11	9
10		48			29			
12		58	50		33	29	14	12
13.5		65	56		38	33	16	13
18		87	75		50	43	22	17
24		115	100		67	58	29	23
27		130	113		75	65	33	26
36		173	150		100	87	43	35
40.5		195			113			39
45			188		125	108	54	
54					150	130	65	52
58.5					163	141	70	56
64					178			
68							82	
81					225		98	
86					239			83
88							106	

16 Gallon with 1-½" inlet and outlet (64 to 88kW)

(Amperage shown in chart below indicates available models)

kW	3 Phase Voltages			
	208	240	480	600
64	178			
68		164	82	
81	225	195	98	
86	239			83
88		212	106	

All information is subject to change without notice. Consult factory for submittal drawings.

Dimensions

UltraPure HD6 – (1.5 to 58.5kW) Sample dimensions are for a HD69R

Shipping Weight: 110 lbs

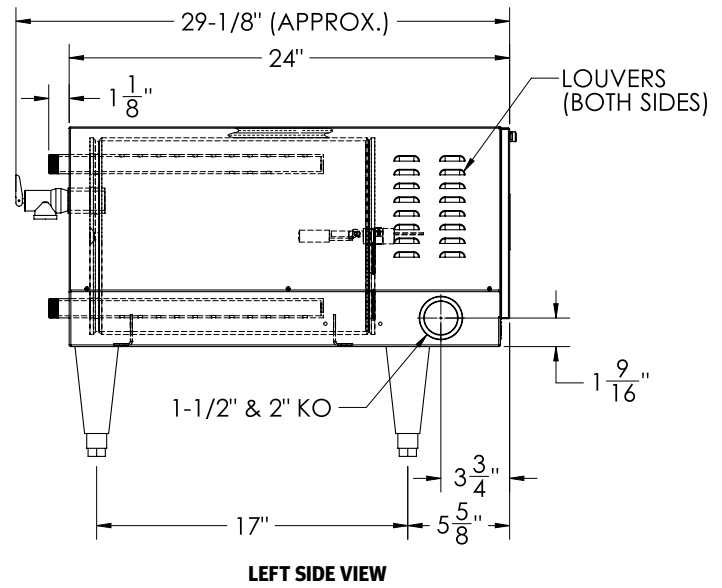
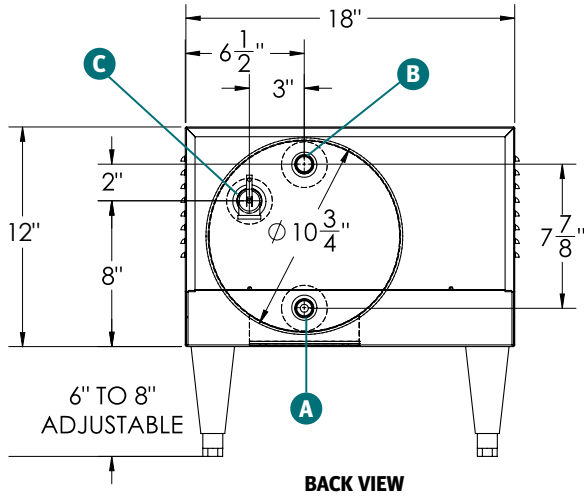

HD6 1.5 to 58.5kW Connections

A	Inlet	3/4" MNPT
B	Outlet	3/4" MNPT
C	Relief Valve	3/4" MNPT

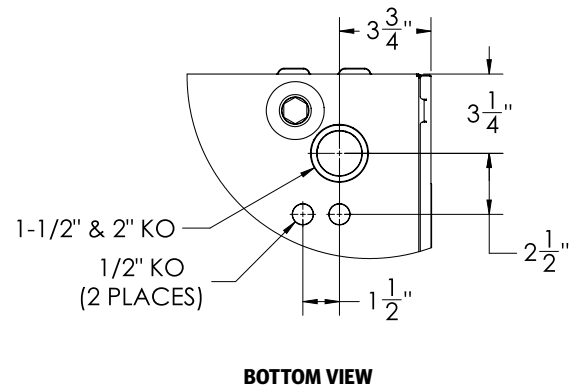

All information is subject to change without notice. Consult factory for submittal drawings.

Dimensions

UltraPure HD16 – (1.5 to 88kW) Sample dimensions are for a HD1666T7

Shipping Weight 1.5 to 58.5kW: 160 lbs

Shipping Weight 64 to 88kW: 175 lbs

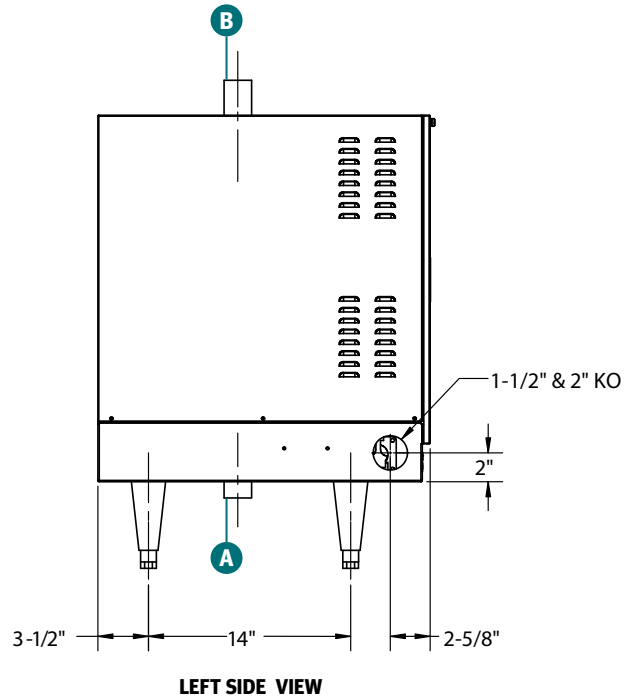
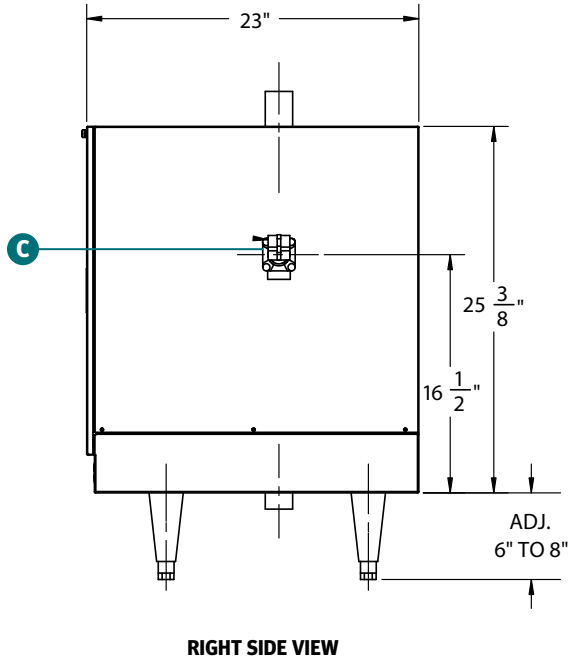

HD16 1.5 to 58.5kW Connections		
A	Inlet	3/4" MNPT
B	Outlet	3/4" MNPT
C	Relief Valve	3/4" MNPT

HD16 64 to 88kW Connections		
A	Inlet	1-1/2" MNPT
B	Outlet	1-1/2" MNPT
C	Relief Valve	1" MNPT

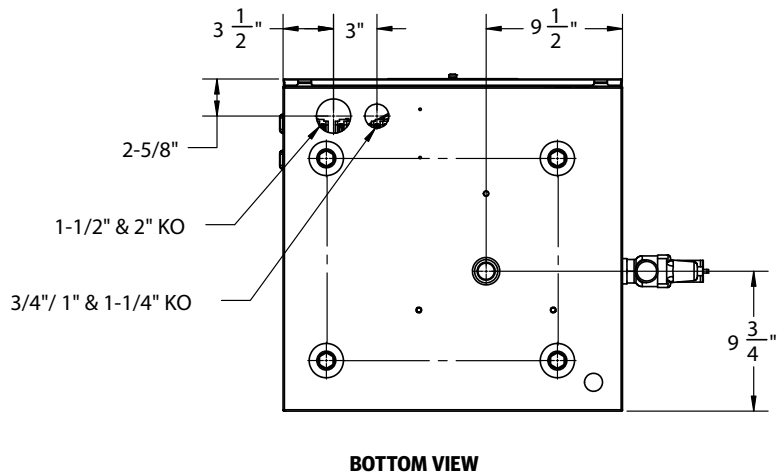

All information is subject to change without notice. Consult factory for submittal drawings.

The UltraPure HDF6 Optional Clean-in-Place Design

The ability for a piece of equipment to be CIP (Cleaned-In-Place) or SIP (Sterilized-In-Place) is a critical feature important to many industries including the food, dairy, beverage, biotechnology, pharmaceutical, cosmetic, and medical industries. In these industries there are hot water applications which require the water heating equipment to be designed and constructed for use in a hygienic environment. To meet this need, Hubbell offers, as an optional feature, an electro polished and

passivated vessel design which includes a removable rear flange to facilitate inspection, cleaning and sterilization of the interior of the water heater vessel with minimal disruption to the production process. This optional feature, designated as the Hubbell UltraPure HDF6 base model, is available in 6-gallon capacity and power ratings ranging from 1.5 to 58.5 KW. The drawing below depicts the removable flange feature, and the selection chart on page 4 provides details on available sizes.

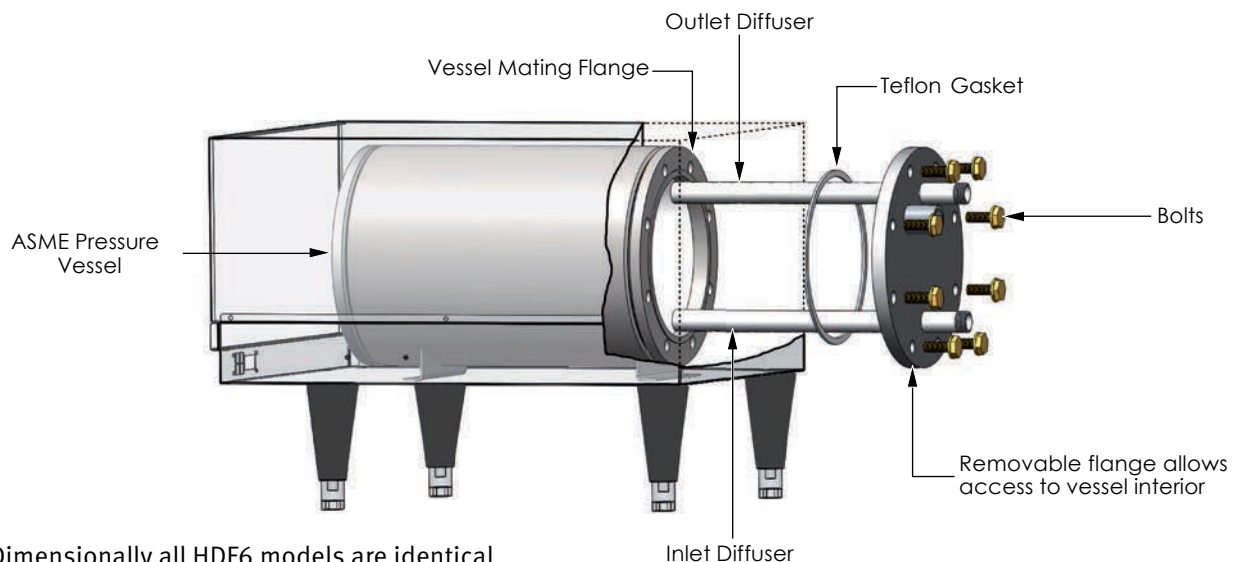

Note: Dimensionally all HDF6 models are identical to model HD6, see page 6 for dimensional details.

Packaged System Option

Fully Packaged Systems

- Engineered and built to meet your exact needs
- Factory integrated system simplifies installation
- Factory selected components ensures reliable performance as a system

Contact Factory Sales Engineer to discuss your Packaged System

Photo shows a 58kW 480V 3Φ packaged system with dual hot water pumps and integrated SCR heater and pump control panel. Factory wired, piped, skid mounted and tested.



Recovery ratings in GPM

kW Rating	Recovery Rate in GPM for °F Temperature Rise Listed Below (°FΔT)									
	20°	30°	40°	60°	70°	80°	100°	110°	120°	140°
1.5	0.51	0.51	0.51	0.51	0.51	0.51	0.51	0.51	0.51	0.51
2.5	0.68	0.68	0.68	0.68	0.68	0.68	0.68	0.68	0.68	0.68
4	1.36	0.91	0.68	0.45	0.39	0.34	0.27	0.25	0.23	0.19
6	2.05	1.36	1.02	0.68	0.58	0.51	0.41	0.37	0.34	0.29
7	2.39	1.59	1.19	0.80	0.68	0.60	0.48	0.43	0.40	0.34
9	3.07	2.05	1.54	1.02	0.88	0.77	0.61	0.56	0.51	0.44
10	3.58	2.39	1.79	1.19	1.02	0.90	0.72	0.65	0.60	0.51
12	4.09	2.73	2.05	1.36	1.17	1.02	0.82	0.74	0.68	0.58
13.5	4.61	3.07	2.30	1.54	1.32	1.15	0.92	0.84	0.77	0.66
18	6.14	4.09	3.07	2.05	1.75	1.54	1.23	1.12	1.02	0.88
24	8.19	5.46	4.09	2.73	2.34	2.05	1.64	1.49	1.36	1.17
27	9.21	6.14	4.61	3.07	2.63	2.30	1.84	1.67	1.54	1.32
36	12.28	8.19	6.14	4.09	3.51	3.07	2.46	2.23	2.05	1.75
40.5	13.82	9.21	6.91	4.61	3.95	3.45	2.76	2.51	2.30	1.97
45	15.35	10.24	7.68	5.12	4.39	3.84	3.07	2.79	2.56	2.19
54	18.42	12.28	9.21	6.14	5.26	4.61	3.68	3.35	3.07	2.63
58.5	19.96	13.31	9.98	6.65	5.70	4.99	3.99	3.63	3.33	2.85
64	21.84	14.56	10.92	7.28	6.24	5.46	4.37	3.97	3.64	3.12
68	23.20	15.47	11.60	7.73	6.63	5.80	4.64	4.22	3.87	3.31
81	27.64	18.42	13.82	9.21	7.90	6.91	5.53	5.02	4.61	3.95
86	29.34	19.56	14.67	9.78	8.38	7.34	5.87	5.34	4.89	4.19
88	30.03	20.02	15.01	10.01	8.58	7.51	6.01	5.46	5.00	4.29

Voltage De-Rating Factors

Rated Voltage	Applied Voltage	De-Rating Factor
600	575	92%
600	550	84%
480	460	92%
480	440	84%
240	230	92%
240	220	84%

When the actual supply voltage (applied voltage) is different than the design voltage (rated voltage) the resulting kW output will be affected. Please see the chart for typical voltage de-rating factors, or use the following formula.

$$\frac{\text{Applied Voltage}^2}{\text{Rated Voltage}^2} \times \text{Rated kW} = \text{kW output at applied voltage}$$

All information is subject to change without notice. Consult factory for submittal drawings.

UltraPure HD Sizing Information

Versatile and Cost reducing design

In a continuous flow application...

with a constant flow of water the HD model operates similar to an instantaneous, on-demand heater with the kW sized to meet the full GPM flow rate and temperature rise of the system.

In an Intermittent flow application...

with an ON/OFF cyclical demand (as in wash and rinse systems) the HD model will heat to the desired GPM flow

rate and temperature while reducing your peak power load. This is achieved due to the small reserve capacity of the Hubbell HD model which continues to be heated during the cycle OFF period in order to meet the full demand during the cycle ON period. This feature results in a significant reduction in your peak power consumption rate, increased temperature accuracy, and lower installation and operating costs when compared to an instantaneous heater.

IF the application is a continuous demand at a constant GPM then go directly to the recovery rate chart on page 8 and choose the appropriate kW which equals the flow rate at the desired temperature rise.

IF the application is an intermittent on / off cyclical system, the following steps will help determine the appropriate size HD model

Variables to Solve For:

Step 1: Determine the variables listed below.

Variables

1. Hot Water Flow Rate: _____ GPM
2. Time hot water at above rate is required: _____ Minutes
3. Time between usages: _____ Minutes
4. Total Cycle Time (Add #2 and #3) _____ Minutes
5. Total Gallons used per cycle (#1 x #2) _____ Gallons
6. Water Temperature:
_____ °F Incoming Cold
_____ °F Outgoing Hot

Step 2: If variable #5 is between:

- 1–9 gallons then select HD6 model and Y=5
- 10–35 gallons then select HD16 model and Y=13
- Over 35 gallons see model D brochure for storage type or model CR brochure for large instantaneous Type DI water heaters.

Step 3:

$$\frac{\text{Gallons per cycle – Y}}{\text{(Variable 5)}} \times 1.15 = \text{RGPM}$$
$$\frac{\text{Time On} \times 0.80}{\text{(Variable 2)}}$$

Step 4:

$$\frac{\text{(RGPM} \times \text{Total Cycle Time)}}{\text{(Variable 4)}} - \frac{\text{Gallons Per Cycle}}{\text{(Variable 5)}} \geq 0$$

If true, then go to Step 6

If false, then continue to Step 5

Step 5: If 0 then use the following formula:

$$\frac{\text{Gallons per cycle (Variable 5)}}{\text{Total Cycle Time (Variable 4)}} \times 1.15 = \text{RGPM}$$

Step 6: Take the RGPM value solved for either in Step 3 or Step 5 above and go to the recovery rating GPM chart. Choose the appropriate temperature rise column and find a GPM rating equal or greater than RGPM. Select the appropriate model for the voltage and phase available.

All information is subject to change without notice. Consult factory for submittal drawings.

Example: A parts wash station requires 4 GPM of 160°F DI water. The entering cold water is 60°F. The rinse cycle is on for 5 minutes at full flow and then off for 10 minutes. The power available is 480-volt 3 phase.

Step 1

Solve for variables

1. Flow Rate: 4 GPM
2. Cycle Time On: 5 Minutes
3. Cycle Time Off: 10 Minutes
4. Total Cycle Time: 15 Minutes
5. Gallons Per Cycle: 20 Gallons
6. Cold Water: 60°F
7. Hot Water: 160°F

Step 2: Gallons per cycle is 20, therefore the HD16 Base Model is used and variable Y=13

Step 3: $20 - 13 = 7 \div (5 \times .80) = 1.75 \times 1.15 = 2.0 \text{ GPM}$

Step 4: $2.0 \times 15 = 30 - 20 = 10 > 0$

Step 5: Not required because step 4 is true

Step 6: From the recovery rating selection chart go to the 100°FΔT column and select the kW that will provide at least 2.0 GPM as determined in Step 3.

In this case, select the 36 kW size and the HD16 Model as determined in Step 2.

Specify Model HD1636T4

Note: In comparison an instantaneous design would require a 58 kW heater.



Manifold Assembly Option:

- Single point connection
- High demand applications
- Multiple units for redundancy
- Contact Sales to specify

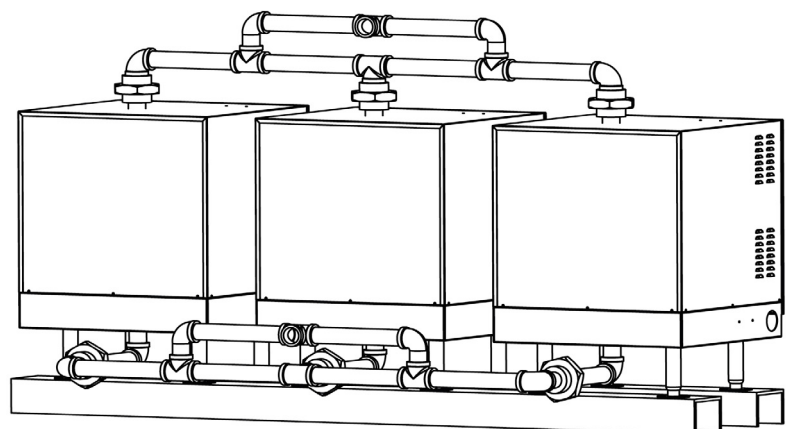

UltraPure HD Model Number Designation

MODEL	See charts on pages 4 & 5	VOLTAGE / PHASE		OPTIONAL EQUIPMENT
	kW Rating			
HD6	1-88	A = 120/1	R = 208/3	Write/type optional equipment code in the gray box below in alphabetical order. For multiple options separate codes with a dash (-)
HDF6		RS = 208/1	T = 240/3	
HD16		S = 240/1	T3 = 380/3/50	
	W = 277/1	T7 = 415/3/50		
	T4S = 480/1	T5 = 440/3		
		T4 = 480/3	T6 = 600/3	

Example: HD645T4-C55

A deionized water heater model HD with 6 gallons storage capacity, 45 kW rated at 480 volt 3 phase 60Hz power, with optional low temp alarm dry contact.

Note: For voltages not shown on pages 4 and 5, consult factory.

Optional Equipment

Note: Optional equipment must be called out in the written specifications, use the codes below.

Controller

- C21** Alarm contact for fault condition (specify N.O. or N.C.)
- C35** BACnet communication
- C49** Solid state power controllers for increased temperature accuracy
- C51** Remote Control Display allows the heater to be installed in a remote location. The 3" x 5" NEMA 4 display enclosure can be located up to 25' from the heater
- C55** Low temp alarm dry contact
- C58** Pump interlock terminal block to prevent energizing (when pump is not on)

General

- G22** 316L Stainless Steel Temperature and Pressure relief valve
- G42** Flanged toe adjustable legs stainless steel

Vessel

- V15** 3/4" additional tank tapping
- V16** 1-1/2" additional tank tapping (HD16 only)
- V40** Flanged inlet and outlet connections (ANSI Class 150, please specify size)
- V41** Alternate threaded inlet/outlet connections size
- V42** Sanitary connections (specify size)

Please note: Optional equipment may impact overall dimensions and weight. Please request submittal drawing from factory.

Available Accessories

10-year Warranty: 10-year non pro-rated tank warranty, specify part number "VESSEL WARRANTY"

Slide Brackets: For mounting the heater under a counter, specify part number "SLIDE BRACKETS"

Protective Cover: Water resistant rip-stop 18 oz. grey FR vinyl coated polyester scrim cover. Removable and form-fitted with Velcro fasteners and clear window showing digital display. **HD6** specify part number "J6-SHROUD," **HD16** specify part number "J16-SHROUD"

Fill out form below to order accessories.

Accessories Name Part #

Accessories Name Part #

Accessories Name Part #

All information is subject to change without notice. Consult factory for submittal drawings.

H1083-B-20240916