



COMMERCIAL and INDUSTRIAL BUFFER TANKS



HYDRONIC BUFFER TANKS

Capacities up to 5000 Gallons

Efficient Management of Thermal Energy

The primary function of a buffer tank is to prevent short cycling of a boiler or chiller. Buffer tanks store energy produced in a boiler or chiller and release this energy as required into the system. Typical systems operate well below design loads and the use of a buffer tank introduces this stored energy in lieu of cycling the boiler or chiller, this reduction in cycling increases equipment longevity.

Hubbell offers traditional two and four port design configurations with a range of connection sizes as referenced in our submittal data sheets. To meet the wide scope of job site specific connection sizes, the Hubbell buffer tank can also be configured with owner specific requirements.

Specifications

- Designed and constructed per ASME Section VIII, Division 1
- Construction: Carbon Steel with Exterior red oxide primer finish
- Maximum Design Pressure and Temperature: 160 psi @ 375°F
- Registered with the National Board of Pressure Vessel Manufacturers
- Warranty 5 Years

Optional Features

- 304 SS or 316L SS construction
- Higher design pressures and temperatures
- Alternate Connection sizes available
- Insulation and Jacketing



CRN

Hubbell Buffer Tanks - Outline Dimensions

2 Port Buffer Tank

INLET	OUTLET
2" FNPT	2" FNPT
3" FNPT	3" FNPT
4"-150# FL'G	4"-150# FL'G
5"-150# FL'G	5"-150# FL'G
6"-150# FL'G	6"-150# FL'G

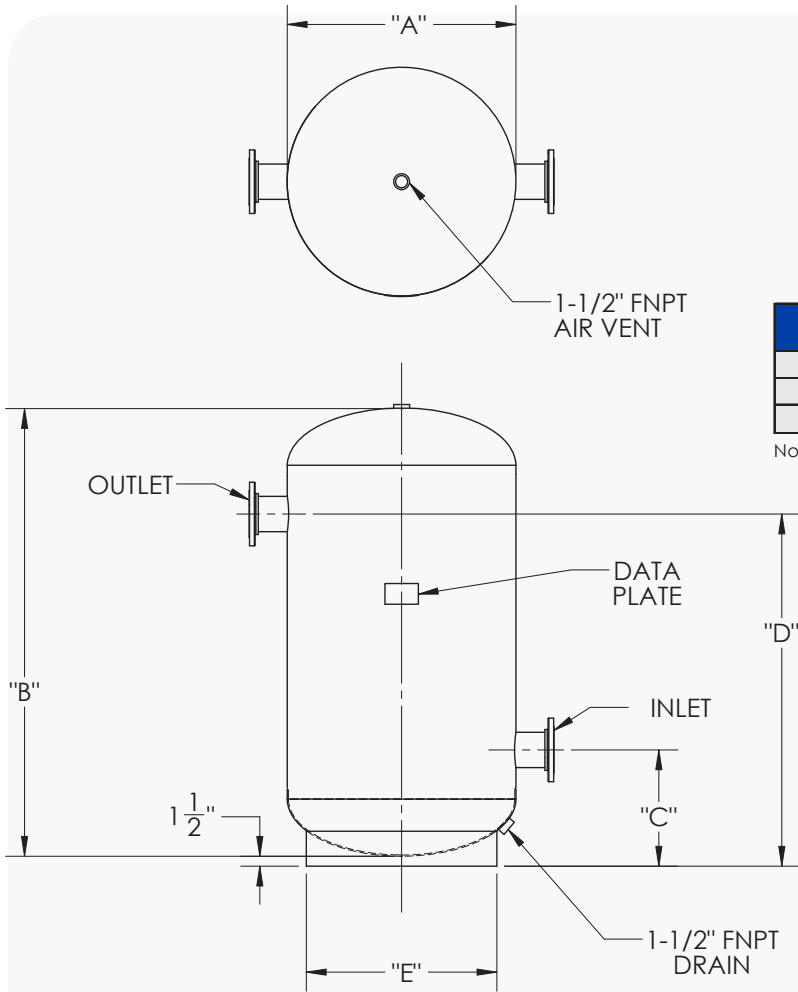

VOLUME	A	B	C	D	E	WEIGHT (LBS.)	
						DRY	WET
120 GAL.	24"	58 1/2"	13"	48 1/2"	20"	398	1398
210 GAL.	30"	73 1/2"	15"	61 1/2"	24"	563	2312
300 GAL.	36"	70 1/2"	18 1/4"	55 1/2"	30"	715	3214

Note: Additional sizes available up to 5,000 gallons
Horizontal configuration available, please consult factory

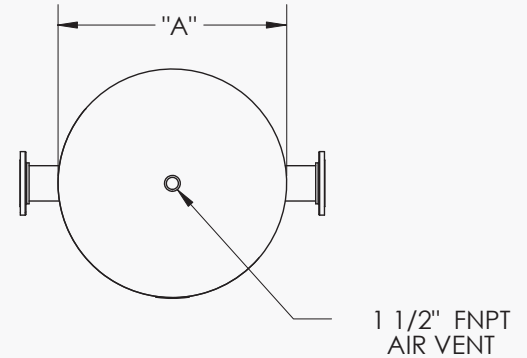

4 Port Buffer Tank

INLET	OUTLET
2" FNPT	2" FNPT
3" FNPT	3" FNPT
4"-150# FL'G	4"-150# FL'G
*5"-150# FL'G	*5"-150# FL'G
*6"-150# FL'G	*6"-150# FL'G

VOLUME	A	B	C	D	E	WEIGHT (LBS.)	
						DRY	WET
120 GAL.	24"	58 1/2"	13"	48 1/2"	20"	398	1398
210 GAL.	30"	73 1/2"	15"	61 1/2"	24"	563	2312
300 GAL.	36"	70 1/2"	18 1/4"	55 1/2"	30"	715	3214

Note: Additional sizes available up to 5,000 gallons
Horizontal configuration available, please consult factory
*Secondary inlet/outlet dimensions need to specified

