



OPERATING AND MAINTENANCE MANUAL

SEAFARE MSE

11/28/23



-IMPORTANT-

Always reference the full model number and serial number when calling the factory.

HUBBELL ELECTRIC HEATER COMPANY
45 SEYMOUR STREET
STRATFORD, CT 06615

PHONE: (203) 378-2659

FAX: (203) 378-3593

Hubbellheaters.com

Table of Contents

SECTION I - GENERAL DESCRIPTION AND CONSTRUCTION	4
GENERAL DESCRIPTION.....	5
Standard Tank Construction	5
Optional Tank Construction	5
TANK CONNECTIONS.....	5
HEATING ELEMENT	5
CONTROL THERMOSTAT	5
TEMPERATURE HIGH LIMIT SWITCH	6
MAGNETIC CONTACTOR	6
OUTER SHELL AND INSULATION	6
OPTIONS.....	6
Built-in Circuit Breaker.....	7
Electro-Mechanical Timer	7
SECTION II – INSTALLATION	8
WATER HEATER PLACEMENT	8
SECURING OF HEATER.....	8
PIPING INSTALLATION.....	9
FILLING THE HEATER	9
ELECTRICAL INSTALLATION	10
FINAL CHECKS.....	10
SECTION III – SCHEDULED MAINTENANCE AND OPERATION	11
MAINTENANCE AND OPERATION	11
FREEZING.....	11
QUARTERLY INSPECTION	11
ANNUAL INSPECTION	11
SECTION IV – TROUBLESHOOTING	12
SECTION V - SERVICING & REPLACEMENT OF PARTS	13
SURFACE TEMPERATURE HIGH LIMIT CUT-OFF	13
IMMERSION TEMPERATURE HIGH LIMIT CUT-OFF	13
HEATING ELEMENT	14
SURFACE MOUNTED THERMOSTAT	15
IMMERSION THERMOSTAT	16
MAGNETIC CONTACTOR	17

RELIEF VALVE	17
SECTION VI – MISCELLANEOUS CHARTS AND FORMULAS	18
ELEMENT CHART	18
FORMULAS	18
TORQUE VALUES	19
SECTION VII – ABS TYPE APPROVAL PROGRAM	20

WARNING / CAUTION

1. Tank is to be completely filled with water and all air is to be vented before energizing.
2. Due to the rigors of transportation, all connections should be checked for tightness before the heater is placed in operation.
3. Safety relief valve must be installed in tapping provided.
4. The refractory material used in heating elements may absorb some moisture during transit, periods of storage, or when subjected to a humid environment. This moisture absorption results in a cold insulation resistance of less than one (1) megohms. If this heater has been subjected to the above condition, each heating element must be checked for insulation resistance before energizing. A low megohm condition can be corrected by removing the terminal hardware and baking the element in an oven at 300°F -500°F for several hours or until the proper megohm reading is obtained.
5. **KEEP AWAY FROM LIVE ELECTRICAL CIRCUITS.**
Do not perform any maintenance, make any adjustments, or replace any components inside the control panel with the high voltage power supply turned on. Under certain circumstances, dangerous potentials may exist even when the power supply is off. To avoid casualties, always turn the power supply safety switch to off, turn the charge or ground the circuit before performing any maintenance or adjustment procedure.
6. The unit is designed to operate at pressure not more than 100 psi.
7. Generalized instructions and procedures cannot anticipate all situations. For this reason, only qualified installers should perform the installations. A qualified installer is a person who has licensed training and a working knowledge of the applicable codes, regulations, tools, equipment, and methods necessary for safe installation of an electric resistance water heater. If questions regarding installation arise, check your local plumbing and electrical inspectors for proper procedures and codes. If you cannot obtain the required information, contact the company.

SECTION I - GENERAL DESCRIPTION AND CONSTRUCTION

MODEL MSE DIMENSIONAL DATA

Storage Capacity (Gallons)	Maximum KW Input	Dimensions (Inches)			
		Diameter	Height	Floor to Inlet	Floor to T&P
6	3	14	17.5	5	12
10	10	20	21	7	15
20	10	20	33	7	27
30	20	20	41.5	7	34
40	20	20	58.75	7	51
50	58	22.75	51	7	43
65	58	26	48	8	40
80	58	26	58	8	51
100	58	26	69.5	8	62
120	58	28	69.25	8	62
40	58	26	33	7	24

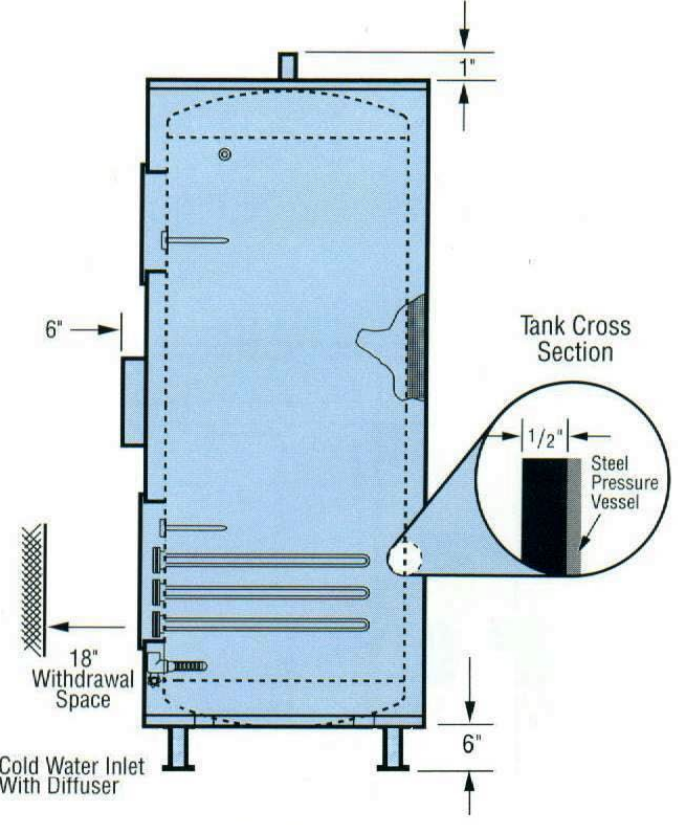
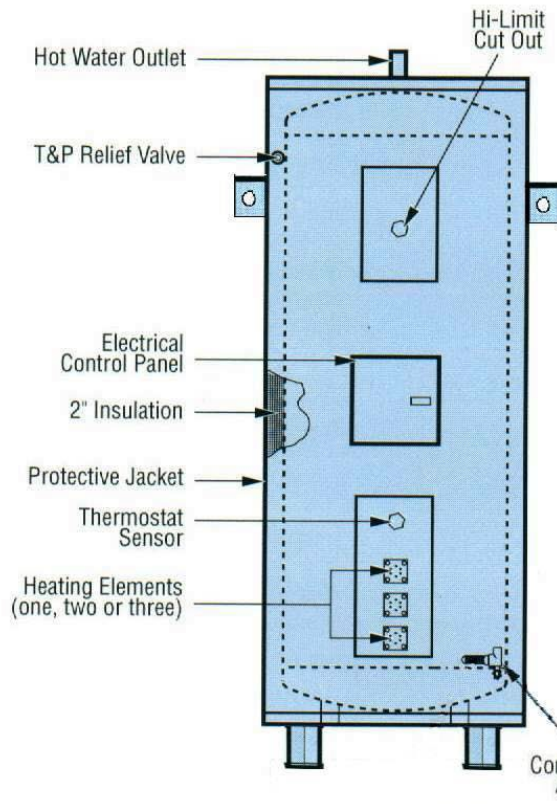
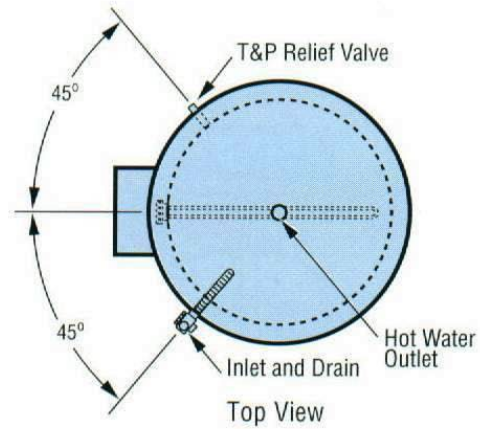

GENERAL DESCRIPTION

This book describes a packaged electric water heater, approved by ABS Americas (A Division of the American Bureau of Shipping) and the USCG (United States Coast Guard), which is a stationary, self-contained unit and is designed and constructed specifically for marine applications on board a surface vessel. The complete assembly consists of the storage tank, immersion electric heating element(s), thermostat, safety relief valve, safety high temperature cut out, magnetic contactor(s), and any other required electrical operating control. Optional equipment may be supplied with your unit. Please consult the product drawing for details specific to your assembly. The unit is factory assembled, insulated, jacketed, wired, tested, and ready for electrical and plumbing service connections.

CONSTRUCTION

Standard Tank Construction:

The standard storage tank is constructed of steel and internally lined with specially formulated HydraStone cement to a ½-inch minimum thickness. The tank is designed for a maximum allowable working pressure of 100 psi (150 psi TP).

Optional Tank Construction:

Optionally, the storage tank may be constructed of all welded solid copper-silicon alloy (ASTM B-96) or type 316L stainless steel for maximum tank longevity. For these options, no internal lining is required due to the non-ferrous materials used in the construction of the pressure vessel. The tank is designed for a maximum allowable working pressure of 100 psi (150 psi TP).

TANK CONNECTIONS

The heater is supplied with separate cold water and hot water connections. Water entering the cold-water inlet is deflected by means of a baffle within the tank. The hot water outlet includes a built-in heat trap to prevent hot water from radiating out from the heater. A ¾-inch FNPT connection is located on the side of the heater for mounting a combination safety temperature and pressure relief valve. An overflow line should be installed from the relief valve outlet to a floor drain. A ¾-inch GHT connection is supplied for draining. See the drawing for locations and sizes.

HEATING ELEMENT

The water heater is supplied with an electric immersion heating element assembly(s), composed of incoloy sheathed elements that are brazed into a brass flange. Each assembly is fastened to a corresponding tank flange using a gasket and four (4) 3/8-16 x 1-inch-long hex head steel bolts and nuts. See the drawing for voltage and power ratings.



CONTROL THERMOSTAT

The water heater is supplied with either a surface mounted or immersion thermostatic switch that is installed and wired at the factory. See the drawing for specific details. The surface mounted thermostat can be adjusted through a range of 110° - 170° F. The immersion thermostat can be adjusted through a range of 100° - 190° F. Both thermostats are adjustable with a flat tip screwdriver.



Surface Mounted Thermostat



Immersion Thermostat

TEMPERATURE HIGH LIMIT SWITCH

As a safety device, either a surface mounted high temperature cut-off switch with manual reset, factory set at 190° F, or an immersion high temperature cut-off switch with manual reset, factory set at 180° F, is provided. In the event of an over-temperature condition, the thermostat will disengage the operating coils in the magnetic contactor(s). The high limit must be manually reset thereafter to restart the heater.



Surface Mounted High Temperature Cut-Off Switch

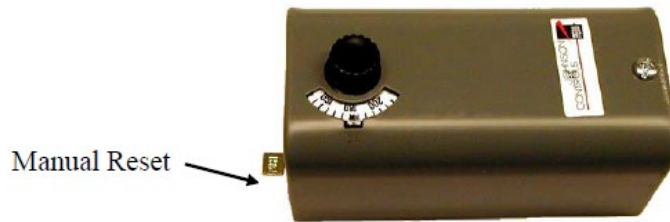

Immersion High Temperature Cut-Off Switch

MAGNETIC CONTACTOR

The magnetic contactor(s) is a heavy-duty resistive load type rated for 100,000 cycles. The contactor supplies power to the heating element(s) and is sized based on the resistive load (non-inductive) rating of the circuit. The contactor supplies power only when the thermostatic switch is engaged, thereby pulling in the contacts until the desired temperature is reached. At this point, the contacts will drop out, which in turn disconnects power from the elements.



OUTER SHELL AND INSULATION

The tank is encapsulated in 2-inch-thick polyurethane foam insulation. The insulation is protected by a high impact non-corroding colorized composite protective jacket.

OPTIONS

The following optional features may be included in your water heater. Reference the included drawing specific to your heater for further details.

Low Water Cut-Off

Used as a safety device, the electronic low water cut-off is used to detect a low water situation and disengage the operating coils in the magnetic contactor(s). Once the condition is remedied, the low water cut-off switch is automatically reset.



Low Water Cut-Off Probe



Low water Cut-Off Relay

Fused Low Voltage Transformer

A fused low voltage transformer may be supplied. This option is used to step down higher voltages to 120-volt for the control circuit.



Dial Temperature and Pressure Gauge

A combination temperature (70° - 250° F) and pressure (0 – 200 psi) gauge with 2½-inch dial may be supplied for in-line installation (shipped loose) or factory installed in the tank.



Vacuum Relief Valve A vacuum relief valve may be provided with the unit to reduce the risk of back siphonage and back pressure of the system. The valve will be shipped loose for in-line installation. Instructions for installation are provided with the valve.



On/Off Switch A built-in non-fused On/Off disconnect switch may be supplied with the control panel to disconnect power to the control panel control and power circuit wiring.

Individually Fused Elements To prevent the possibility of damage to circuits and elements in case of electrical overloads, fuses may be supplied for each circuit. Two types of fuses may be used; a type NON for voltages less than 250-volt or type JJS for voltages less than 600-volt.



Built-in Circuit Breaker

A built-in circuit breaker may be provided with or without shunt trip protection for protection from circuit overload.

Electro-Mechanical Timer

An electro-mechanical 7-day time clock with battery back-up may be supplied for specific timing operations. A set of instructions will be supplied with the timer.



SECTION II – INSTALLATION

WARNING / CAUTION

DO NOT TURN ON THE ELECTRIC POWER SUPPLY to this equipment until the heater is completely filled with water and all air has been released. *If the heater is NOT filled with water when the power is turned on, the heating elements will burn out.*

For protection against excessive pressures and temperatures, code requires the installation of a temperature-and-pressure (T&P) relief valve certified by a nationally recognized laboratory that maintains periodic inspection of production of listed equipment of materials, as meeting the requirements for Relief Valves and Automatic Gas Shutoff for Hot Water Supply Systems. ANSI Z21.22-1971. THE CUSTOMER IS RESPONSIBLE TO PROTECT PROPERTY AND PERSONNEL FROM HARM WHEN THE VALVE FUNCTIONS.

All water heaters have a risk of leakage at some unpredictable time. IT IS THE CUSTOMER'S RESPONSIBILITY TO PROVIDE A CATCH PAN OR OTHER ADEQUATE MEANS, SO THAT THE RESULTANT FLOW OF WATER WILL NOT DAMAGE PROPERTY.

WATER HEATER PLACEMENT

1. Place the heater on a solid foundation in a clean, dry location nearest to the point of most frequent hot water use.
2. The water heater should be protected from freezing and waterlines insulated to reduce energy and water waste.
3. Leave a minimum of 18" clearance for element withdrawal, if necessary.
4. Do not install in an area where flammable liquids or combustible vapors are present.

SECURING OF HEATER

1. The heater is supported by four 2-inch x 2-inch x ¼-inch thick angle iron legs each with a 3-inch x 3-inch x ¼-inch thick steel base pad. Each leg is provided with one 9/16-inch diameter bolt hole for one ½-inch bolt which should be used to secure heater to the deck.
2. In addition to the leg supports, two 3-inch x 3-inch x ¼-inch thick brackets with removable 7/8-inch diameter mounting holes are attached to the upper portion of the heater. These brackets should be attached to bulkhead secured tie-rods thus ensuring further support of the heater for shipboard installation.

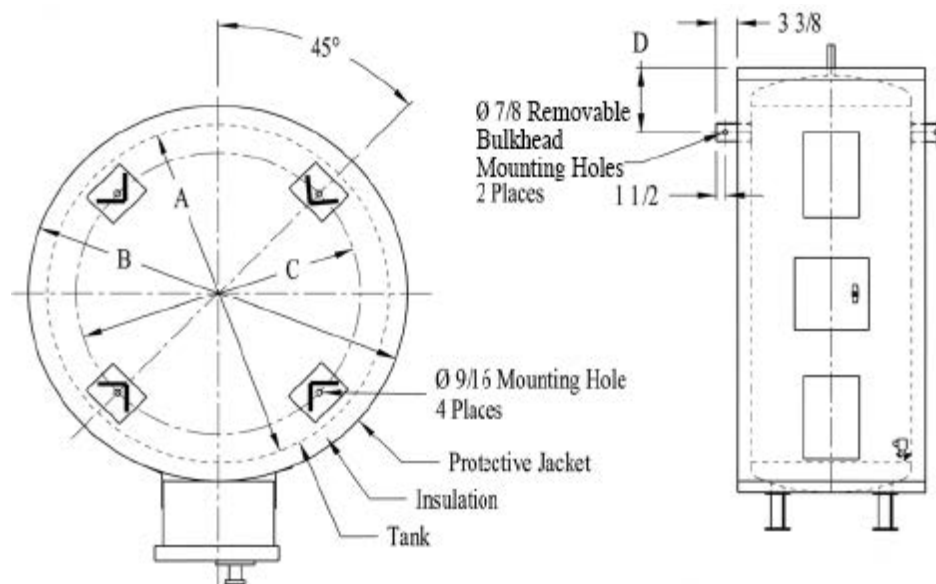

Mounting Dimensions

Tank Diameter "A"	Overall Diameter "B"	Bolt Circle "C"	Bulkhead Mounting Dimension "D"	Gallon Capacity
16	20	12	None	10
16	20	12	None	20
16	20	12	None	30
16	20	12	12	40
18 3/4	22 3/4	16	12	50
22	26	16	12	65
22	26	16	12	80
24	28	18	12	100
24	28	18	12	120

PIPING INSTALLATION

NOTE: The most effective means for preventing deterioration from accelerated corrosion due to galvanic and stray current is the installation of dielectric fittings/unions. The installation of these fittings is the responsibility of the installation contractor.

1. Connect the cold-water inlet and hot water outlet to the appropriate connections as shown; refer to the drawing for location and sizes.
2. Install in-line vacuum breaker, if supplied.
3. Install in-line pressure and temperature gauge, if supplied.
4. Install the combination temperature and pressure safety relief valve in the tapping provided. Note that this is required by law for safety considerations.

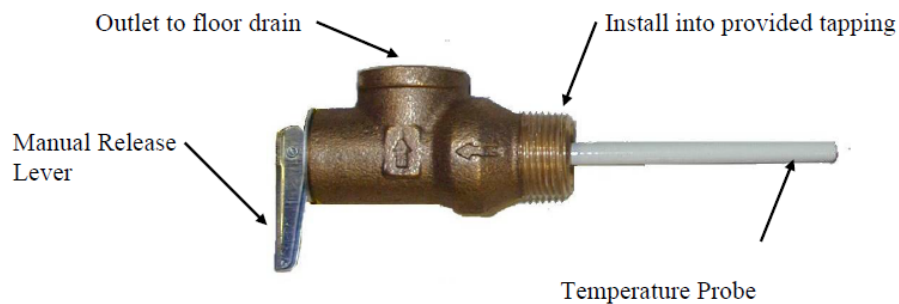

Temperature and Pressure Relief Valve

5. Install a relief valve overflow pipe to a nearby floor drain. **CAUTION:** No valve of any type should be installed between the relief valve and tank or in the drain line.

FILLING THE HEATER

1. Completely close the drain valve.
2. Open the highest hot water faucet to allow all air to escape from piping.
3. Open the valve to the cold-water inlet and allow the heater and piping system to completely fill, as indicated by a steady flow of water from the open faucet.

ELECTRICAL INSTALLATION

1. Enter electric enclosure with properly sized feeder leads. Be sure to properly ground the water heater.
2. Install these power leads into the box lugs on the terminal block or magnetic contactor.
3. Torque screws per torque chart included in Section VI.
4. All other electrical connections are made at the factory; therefore, no other electrical connections are necessary.

FINAL CHECKS

1. Check all connections for tightness.
2. Ensure that all the above steps are completed.
3. After the water is heated for the first time, monitor the water temperature as described in Section III, Quarterly Inspection.

SECTION III – SCHEDULED MAINTENANCE AND OPERATION

WARNING / CAUTION

Before performing any maintenance procedure, make certain power supply is **OFF** and cannot accidentally be turned on.

MAINTENANCE AND OPERATION

The water heater is automatic in its operation. It will maintain a full tank of water at the temperature setting of the thermostat. The water heater should not be turned on without first making sure that the tank is full of water and that all air has been released.

FREEZING

The tank should be fully drained in the event the electricity has been turned off and if there is danger of freezing.

QUARTERLY INSPECTION

1. Monitor thermostat
 - a. Let the water heater completely heat to a designated thermostat setting.
 - b. After the thermostat satisfies (that is, when the thermostat actually clicks off), draw water from heater.
 - c. Compare the water temperature of drawn water to the temperature setting of the thermostat when it satisfies. Normal variation between the two points is approximately $\pm 5^{\circ}\text{F}$.
 - d. If these two readings do not coincide within acceptable tolerances and verification has been made of the accuracy of the temperature-reading gauge, replace the thermostat.
2. Lift test lever on relief valve and let water run through valve for a period of approximately 10 seconds. This will help flush away any sediment that might build up in water passageways.
3. Inspect element flange for leakage as follows:
 - a. Shut off Power Supply.
 - b. Remove element housing cover.
 - c. Visually inspect heating element gasket for evidence of leaks.
 - d. Rub finger around gasket that is between the heating element and tank flange for any evidence of moisture. If moisture is present or a water drip is observed, follow the procedure outlined in Section V.
4. Check for loose electrical connections. Tighten as necessary.

ANNUAL INSPECTION

1. Flush tank as follows:
 - a. Shut off the power supply.
 - b. Close valve on hot water outlet piping.
 - c. Open valve on drain piping.
 - d. Cold water inlet line pressure will be strong enough to flush sediment from the bottom of the tank out through the drain. Let the water run for 3-4 minutes.
 - e. Close drain valve.
 - f. Open hot water valve.
 - g. Turn the power supply ON.

SECTION IV – TROUBLESHOOTING

Symptom	Probable Cause	Corrective Action / Remedy
No hot water	Circuit breaker tripped at source	Reset circuit breaker
	On/Off switch in 'OFF' position, if installed.	Turn switch to 'ON' position.
	Circuit breaker at control cabinet tripped, if installed.	Reset circuit breaker.
	Blown fuse in element fuse block, if installed.	Replace fuse.
	Blown fuse in transformer, if installed.	Replace fuse.
	High limit switch tripped.	Reset high limit switch.
	Loose wires.	Tighten wires. Torque screws per torque chart included in Section VI.
	Heating element inoperable.	Check heating element operation by clamping an Amprobe around each wire to the element. The ampere reading should agree with the nameplate 'AMP' figure.
	Low line voltage.	Have source electrical system checked by an electrician.
	Faulty thermostat.	Move thermostat dial through full range. A definite 'click' should be heard. If not, replace thermostat.
Water temperature below settings at all times	Faulty low water cut-off, if installed.	Check to see if the tank is full of water. If not, fill the tank. If the problem continues and tank is full, check for continuity between the common and normally open contact of the relay board. If continuity is not observed, replace low water cut-off.
	Magnetic contactor does not energize.	Replace complete magnetic contactor. Because of the design of this particular contactor, it is more desirable to replace complete control rather than rebuilding coil, contacts and springs, etc.
	Faulty thermostat.	Check thermostat adjustment. Monitor thermostat as described in Section III, Quarterly Inspection. Replace if necessary.
	Blown fuse in element fuse block, if installed.	Replace fuse.
Relief valve discharges continuously	Heating element not working on all phases	Check to see that heating element is working on all phases, by checking the resistance (ohms) value for each element and comparing with the chart included in Section VI.
	Heater improperly sized	Verify heater is properly sized for the flow rate and temperature rise of your system. See formulas included in Section VI. Replace elements with proper size as necessary.
Relief valve discharges continuously	Excessive temperature or pressure in tank	Temperature and pressure relief valves are made to operate if the water temperature exceeds 210°F or water pressure exceeds the pressure rating of the safety relief valve. If trouble is excessive temperature, then thermostat is not shutting off at the right setting and thermostat must be replaced.

SECTION V - SERVICING & REPLACEMENT OF PARTS

WARNING / CAUTION

Before performing any maintenance procedure, make certain power supply is **OFF** and cannot accidentally be turned on.

SURFACE TEMPERATURE HIGH LIMIT CUT-OFF

1. Disconnect power from unit.
2. Remove access cover.
3. Disconnect the four (4) 14-gauge wires.

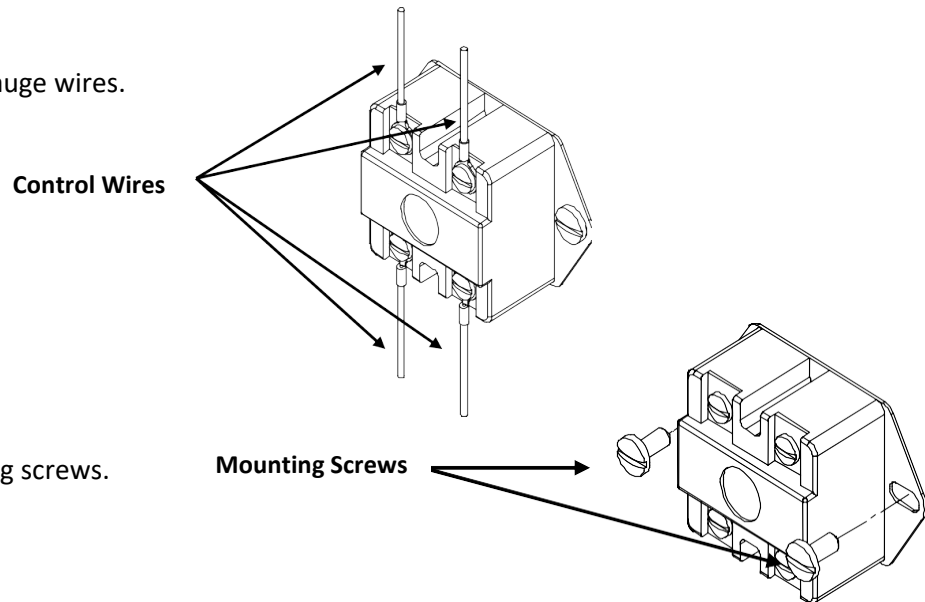

4. Remove the two (2) mounting screws.

5. Replace control and install new high limit switch by performing above steps in reverse order.

See wiring diagram included with drawing for assistance.

IMMERSION TEMPERATURE HIGH LIMIT CUT-OFF

1. Disconnect power from unit.
2. Remove access cover.
3. Remove high limit cover screw and cover.

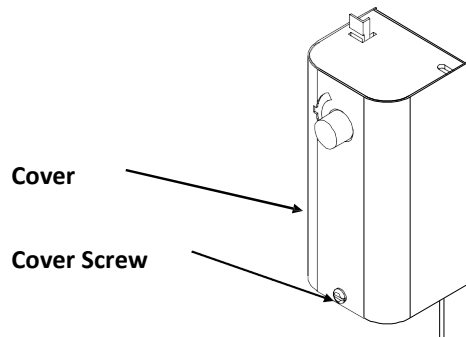

4. Disconnect the two (2) 14-gauge wires.

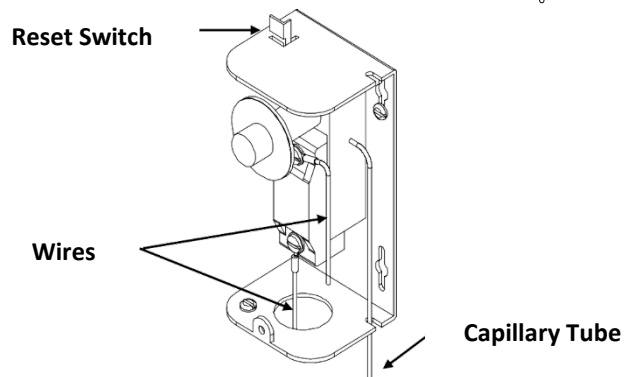

5. Remove capillary tube and bulb from thermowell .

6. Remove two (2) mounting screws.

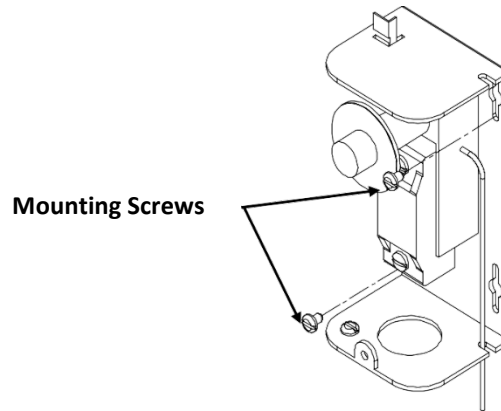

7. Remove control and install new high limit switch by performing above steps in reverse order. (Note: Be sure to place capillary tube into slot in base prior to installing cover.)

HEATING ELEMENT

1. Disconnect power from unit.
2. Shut off incoming water supply.
3. Attach hose to drain connection.
4. Lift manual release lever on relief valve to let air into system or break union on outgoing water line.
5. Drain water from tank.
6. Disconnect the wires from the heating element terminals.
7. Remove the 3/8-16 nuts.

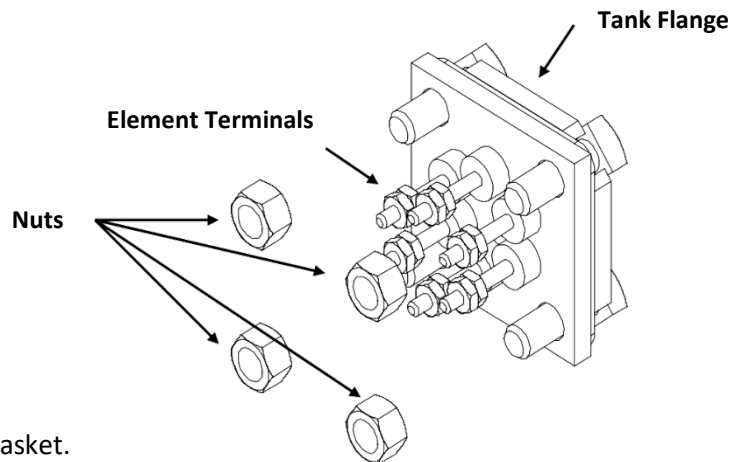

8. Withdraw element assembly and remove gasket.

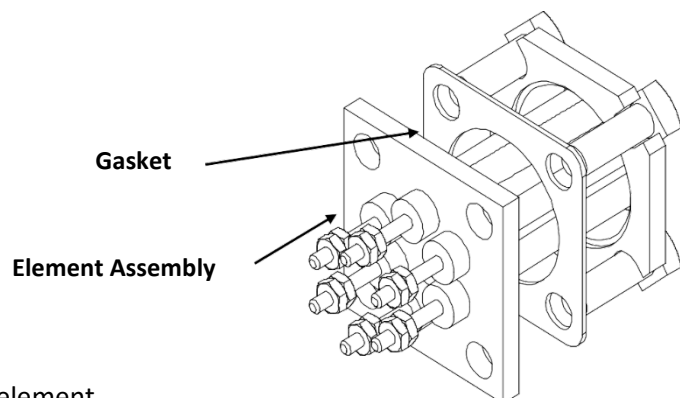

9. Install a new gasket and insert a new heating element.
10. Rewire element according to the voltage and phase rating of the unit as shown below.
11. Fill the tank and check around gasket for any leaks.

JUMPER CONFIGURATION

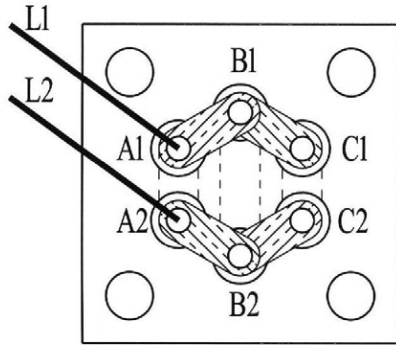

1 PHASE
208 OR 240 VOLT

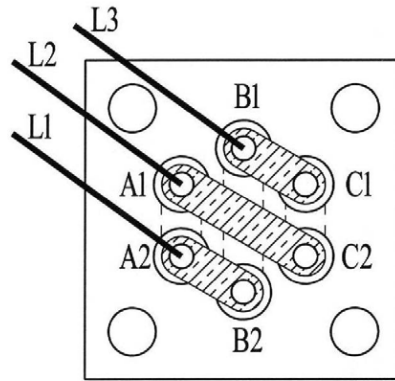

3 PHASE DELTA
208 OR 240 VOLT

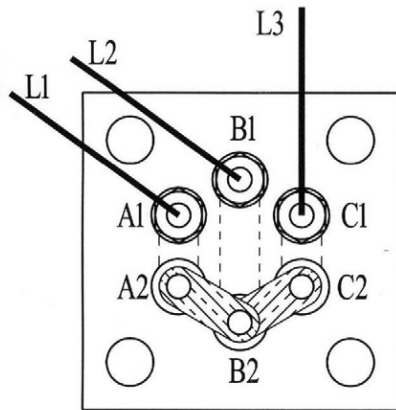

3 PHASE WYE
380 TO 575 VOLT

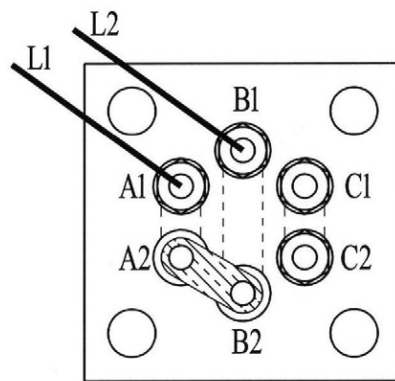

1 PHASE
480 VOLT

SURFACE MOUNTED THERMOSTAT

1. Disconnect power from unit.
2. Remove access cover and locate thermostat.
3. Disconnect the two (2) 14-gauge wires.

Control Wires

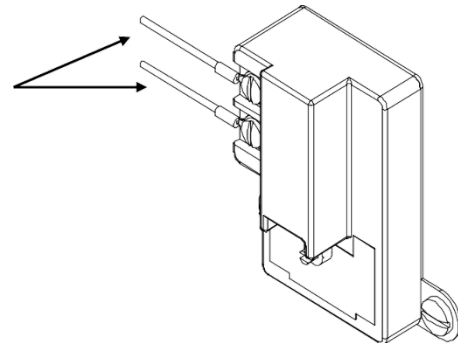

4. Remove two (2) mounting screws.

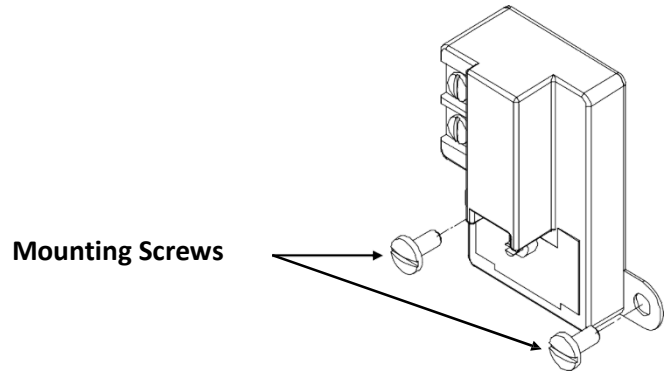

5. Replace thermostat using the reverse procedure.

IMMERSION THERMOSTAT

1. Disconnect power from unit.
2. Remove access cover and locate thermostat.
3. Remove high limit cover screw and cover.

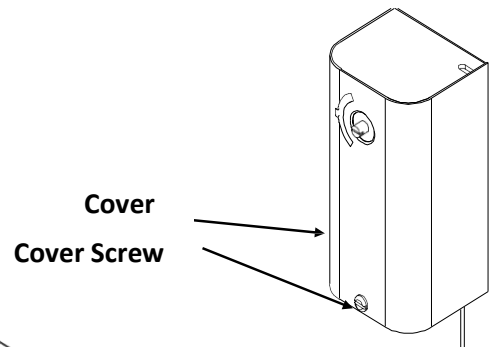

4. Disconnect the two (2) 14-gauge wires.

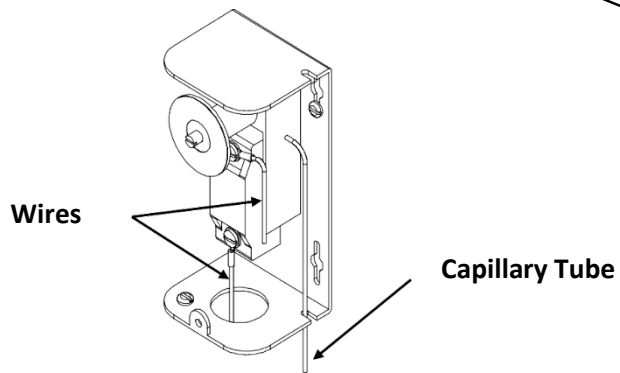

5. Remove capillary tube and bulb from thermowell.
6. Remove two (2) mounting screws.

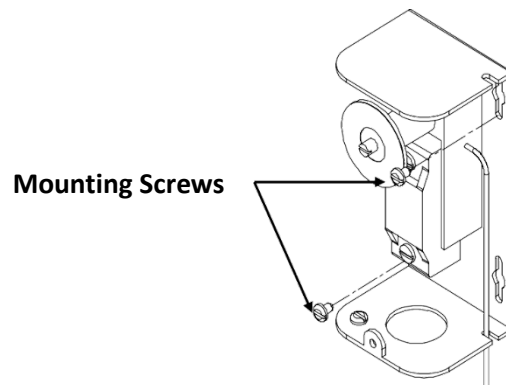

7. Replace thermostat using reverse procedure. (Note: Be sure to place capillary tube into slot in base prior to installing cover.)

MAGNETIC CONTACTOR

1. Disconnect power from unit.
2. Disconnect line and load wires to contactor.
3. Disconnect two (2) 14-gauge control circuit wires.

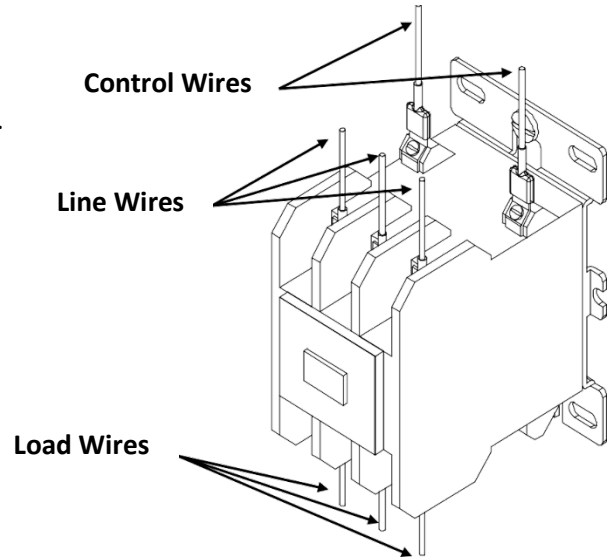

4. Loosen two (2) holding screws and remove contactor.

5. Replace with new contactor using reverse procedure.

**Mounting Screws
(Bottom screw not shown)**

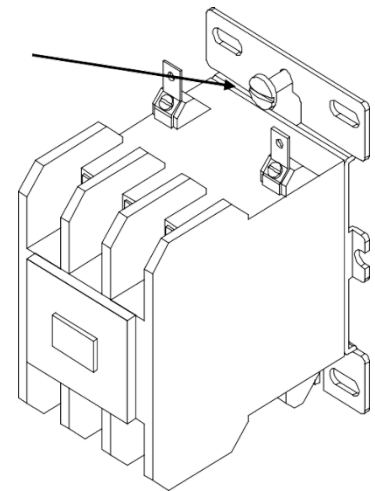

RELIEF VALVE

1. Disconnect power from unit.
2. Shut off incoming water supply.
3. Lift test lever on relief valve to relieve pressure in tank.
4. Disconnect overflow piping.
5. Unscrew relief valve, remove assembly and replace with new one.
6. Connect overflow piping.
7. Turn on incoming water supply and check for leaks.
8. Turn the safety switch to ON position.

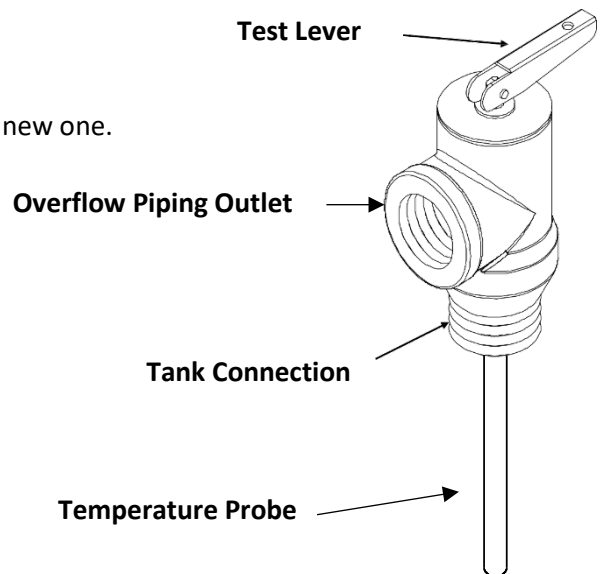

SECTION VI – MISCELLANEOUS CHARTS AND FORMULAS

ELEMENT CHART

Element Part #	Immersion Length	Resistance (Ohms)			
		Hairpin	1 Φ	3 Φ DELTA	3 Φ WYE
2-38683N	13"	57.6	19.2	57.6	38.6
3-38683N	13"	43.2	14.4	43.2	28.9
4-38683N	13"	34.4	11.5	34.4	23.0
5-38683N	13"	27.9	9.3	27.9	18.7
6-38683N	13"	21.6	7.2	21.6	14.5
7-38683N	13"	17.1	5.7	17.1	11.5
8-38683N	13"	14.4	4.8	14.4	9.6
9-38683N	15"	12.1	4.0	12.1	8.1
10-38683N	15"	9.1	3.0	9.1	6.1
11-38683N	15"	7.5	2.5	7.5	5.0

FORMULAS

RECOVERY

$$\text{GPH} \times \text{_____} \text{ } ^\circ\text{F } \Delta\text{T} \times 0.00244 = \text{KW}$$

$$\text{KW} \times 410 \div \text{GPH} = \text{_____} \text{ } ^\circ\text{F } \Delta\text{T}$$

$$\text{KW} \times 410 \div \text{_____} \text{ } ^\circ\text{F } \Delta\text{T} = \text{GPH}$$

Note: 1 KW will heat 4.1 GPH at a 100°F ΔT

ELECTRICAL

$$\frac{\text{KW} \times 1000}{\text{Volts}} \div 1.73 = \text{Amps } 3 \Phi$$

$$\frac{\text{KW} \times 1000}{\text{Volts}} = \text{Amps } 1 \Phi$$

METRIC CONVERSION

$$\text{Liters} \times 0.2641 = \text{Gallons}$$

$$\text{Gallons} \times 3.79 = \text{Liters}$$

$$\text{Gallons} \times 0.003785 = \text{m}^3$$

$$\text{m}^3 \times 264.2 = \text{Gallons}$$

$$1^\circ\text{C } \Delta\text{T} = 1.8^\circ\text{F } \Delta\text{T}$$

$$^\circ\text{F} = (^\circ\text{C} \times 1.8) + 32$$

$$^\circ\text{C} = (^\circ\text{F} - 32) \times 0.556$$

$$\text{psi} \times 0.06896 = \text{Bar}$$

$$\text{Bar} \times 14.5 = \text{psi}$$

$$\text{psi} \times 6.86 = \text{kPa}$$

$$\text{kPa} \times 0.1456 = \text{psi}$$

$$\text{Lbs} \times 0.4536 = \text{Kg}$$

$$\text{Kg} \times 2.2 = \text{Lbs}$$

$$\text{Watts/Sq.Cm.} \times 6.4 = \text{Watts/Sq.In.}$$

$$\text{Watts/Sq.In.} \times 0.155 = \text{Watts/Sq.Cm.}$$

TORQUE VALUES

BOLT SIZE	18-8 S/S IN.-LBS.	BRASS IN.-LBS.	SILICON BRONZE IN.-LBS.	ALUMINUM 2024-T4 IN.-LBS.	316 S/S IN.-LBS.	MONEL IN.-LBS.
4-40	5.2	4.3	4.8	2.9	5.5	5.3
4-48	6.6	5.4	6.1	3.6	6.9	6.7
5-40	7.7	6.3	7.1	4.2	8.1	7.8
5-44	9.4	7.7	8.7	5.1	9.8	9.6
6-32	9.6	7.9	8.9	5.3	10.1	9.8
6-40	12.1	9.9	11.2	6.6	12.7	12.3
8-32	19.8	16.2	18.4	10.8	20.7	20.2
8-36	22.0	18.0	20.4	12.0	23.0	22.4
10-24	22.8	18.6	21.2	13.8	23.8	25.9
10-32	31.7	25.9	29.3	19.2	33.1	34.9
1/4-20	75.2	61.5	68.8	45.6	78.8	85.3
1/4-28	94.0	77.0	87.0	57.0	99.0	106.0
5/16-18	132	107	123	80	138	149
5/16-24	142	116	131	86	147	160
3/8-16	236	192	219	143	247	266
3/8-24	259	212	240	157	271	294
7/16-14	376	317	349	228	393	427
7/16-20	400	327	371	242	418	451
1/2-13	517	422	480	313	542	584
1/2-20	541	443	502	328	565	613
9/16-12	682	558	632	413	713	774
9/16-18	752	615	697	456	787	855
5/8-11	1110	907	1030	715	1160	1330
5/8-18	1244	1016	1154	798	1301	1482
3/4-10	1530	1249	1416	980	1582	1832
3/4-16	1490	1220	1382	958	1558	1790
7/8-9	2328	1905	2140	1495	2430	2775
7/8-14	2318	1895	2130	1490	2420	2755
1-8	3440	2815	3185	2205	3595	4130
1-14	3110	2545	2885	1995	3250	3730

SECTION VII – ABS TYPE APPROVAL PROGRAM



CERTIFICATE NUMBER
19-HS1822437-PDA

DATE
06 Feb 2019

ABS TECHNICAL OFFICE
Houston ESD - Piping

CERTIFICATE OF Design Assessment

This is to certify that a representative of this Bureau did, at the request of

HUBBELL ELECTRIC HEATER COMPANY

assess design plans and data for the below listed product. This assessment is a representation by the Bureau as to the degree of compliance the design exhibits with applicable sections of the Rules. This assessment does not waive unit certification or classification procedures required by ABS Rules for products to be installed in ABS classed vessels or facilities. This certificate, by itself, does not reflect that the product is Type Approved. The scope and limitations of this assessment are detailed on the pages attached to this certificate.

Product: Heater, Water

Model: MSE Series, Shipboard Electric Water Heater

This Product Design Assessment (PDA) Certificate 19-HS1822437-PDA, dated 06/Feb/2019 remains valid until 05/Feb/2024 or until the Rules or specifications used in the assessment are revised (whichever occurs first).

This PDA is intended for a product to be installed on an ABS classed vessel, MODU or facility which is in existence or under contract for construction on the date of the ABS Rules or specifications used to evaluate the Product.

Use of the Product on an ABS classed vessel, MODU or facility which is contracted after the validity date of the ABS Rules and specifications used to evaluate the Product, will require re-evaluation of the PDA.

Use of the Product for non ABS classed vessels, MODUs or facilities is to be to an agreement between the manufacturer and intended client.

AMERICAN BUREAU OF SHIPPING

Tim Kimble
Engineer/Consultant

NOTE: This certificate evidences compliance with one or more of the Rules, Guides, standards or other criteria of ABS or a statutory, industrial or manufacturer's standards. It is issued solely for the use of ABS classed vessels, its clients or other authorized entities. Any significant changes to the aforementioned product without approval from ABS will result in this certificate becoming null and void. This certificate is governed by the terms and conditions as contained in ABS Rules 14.05.7.1.9.1 Terms and Conditions of the Request for Product Type Approval and Agreement (2017)

ABS256.01105

HUBBELL ELECTRIC HEATER COMPANY
45 SEYMOUR STREET
STRATFORD CT
United States 06615-0288
Telephone: 203-378-2659
Fax: 203-378-3593
Email: ARogers@hubbellheaters.com
Web: www.hubbellheaters.com

Tier: 5 - Unit Certification Required

Product: Heater, Water
Model: MSE Series, Shipboard Electric Water Heater
Intended Service: Marine Application - Designed to provide Potable Hot Water for Onboard Commercial Marine requirements (Non-Pleasure Craft). Units are designed for weather deck locations.
Description: Package Commercial Electric Type Water Heaters. Vertical or Horizontal, Jacketed, Insulated including all necessary and required operating controls.
Rating:
Model MSE with 14" to 26" O.D.
Maximum Working Pressure: 160 psig
Maximum Design Temperature: 190 °C (210 °F)
Storage Capacity: 5 to 120 Gallons (U.S.)
Volts Range: 120 thru 600 Volts
Thermostat Range: 110 - 170 °F (H Limit: 190 °F)
Relief Valve Type: T&P, 210 °F, 160 psi
Service Restriction:
- Unit Certification is required for the storage tank in accordance with the requirements of 4-4-1/7 of the Marine Vessels Rules.
- For weather deck locations, NEMA 4 or 4X enclosures to be employed.
Comments:
1. The Manufacturer has provided a declaration about the control of, or the lack of Asbestos in this product.
2. Welding is to be performed in accordance with approved procedures. Procedure qualification records, welder qualifications and production welds are to be maintained for records.
3. Overcurrent protection shall be supplied by the end user at the time of final installation.
4. Acceptance is based on Manufacturer's guarantee that the Electric Water Heater is constructed to the standard and conforms to the identifications to which it is marked.
5. Seating arrangements on board ship are to be to the attending Surveyor satisfaction, as per Marine Vessels Rules 4-4-1/9.1. For vertically mounted units, anti-rolling stays should be provided to minimize the loads applied to the lower head to shell weld due to the motions of the vessel.
Notes/Drawing/Documentation:
Dwg. No. 15-3944 Rev. -, Model MSE120-0-36SLT4 120 Gallon 36kW 480V 3 Phase 60Hz
ASME Certificate of Authorization "H", Certificate No. 33,772 dated 12 Dec. 2016, Expires 30 Jan. 2020
ASME Certificate of Authorization "U", Certificate No. 33,773 dated 12 Dec. 2016, Expires 30 Jan. 2020
ASME Certificate of Authorization "HLW", Certificate No. 37,239 dated 12 Dec. 2016, Expires 30 Jan. 2020
BDJS.E51660 Boiler Electric - UL Certification
KSDT.E70324 Household Water Heaters, Storage Tank - UL Certification
KSHZ.E70323 Commercial Storage Tank and Booster Water Heaters - UL Certification
Product Catalog, Model MSE Shipboard Electric Water Heater
Terms of Validity:
This Product Design Assessment (PDA) Certificate 19-HS1822437-PDA, dated 06/Feb/2019 remains valid until 05/Feb/2024 or until the Rules or specifications used in the assessment are revised (whichever occurs first).
This PDA is intended for a product to be installed on an ABS classed vessel, MODU or facility which is in existence or under contract for construction on the date of the ABS Rules or specifications used to evaluate the Product.

As of 06/Feb/2019 Type Approved Page 1 of 2

HUBBELL ELECTRIC HEATER COMPANY
45 SEYMOUR STREET
STRATFORD CT
United States 06615-0288
Telephone: 203-378-2659
Fax: 203-378-3593
Email: ARogers@hubbellheaters.com
Web: www.hubbellheaters.com

Tier: 5 - Unit Certification Required

Use of the Product on an ABS classed vessel, MODU or facility which is contracted after the validity date of the ABS Rules and specifications used to evaluate the Product, will require re-evaluation of the PDA.

Use of the Product for non ABS classed vessels, MODUs or facilities is to be to an agreement between the manufacturer and intended client.

STANDARDS

ABS Rules:
Rules for Conditions of Classification, Part 1, 2019 Marine Vessels Rules 1-1-4/7, 1-1-A3, 1-1-A4, which covers following:
Marine Vessels Rules (2019) 4-4-1/1.5, 4-4-1/17.1

National:
2017 ASME Boiler and Pressure Vessel Code Section IV - rules for construction of Heating Boilers

International:
NA

Government:
46CFR 53.01-03

EUMED:
NA

OTHERS:
NA

As of 06/Feb/2019 Type Approved Page 2 of 2

HUBBELL ELECTRIC HEATER COMPANY
45 SEYMOUR STREET
STRATFORD, CT 06615

PHONE: (203) 378-2659
FAX: (203) 378-3593
Hubbellheaters.com