



OPERATING AND MAINTENANCE MANUAL

Synergy PS

9/7/23



-IMPORTANT-

Always reference the full model number and serial number when calling the factory.

HUBBELL ELECTRIC HEATER COMPANY
45 SEYMOUR STREET
STRATFORD, CT 06615

PHONE: (203) 378-2659
FAX: (203) 378-3593
Hubbellheaters.com

Table of Contents

SECTION I - GENERAL DESCRIPTION AND CONSTRUCTION	4
GENERAL DESCRIPTION.....	4
TANK	4
STEAM HEATING COIL	4
OUTER SHELL, INSULATION, AND SUPPORTS.....	4
STEAM OPERATING CONTROLS.....	4
Strainers	4
Traps	5
OPTIONS.....	5
SECTION II – INSTALLATION	6
WATER HEATER PLACEMENT	6
PIPING INSTALLATION	8
ELECTRICAL INSTALLATION	8
FILLING THE HEATER	8
SECTION III – INSTALLATION AND OPERATION OF STERLCO TEMPERATURE CONTROL VALVES	9
TROUBLESHOOTING.....	10
SECTION IV – OPERATION	11
STARTUP.....	11
SHUTDOWN	11
SECTION V – SCHEDULED MAINTENANCE AND SERVICING	12
QUARTERLY INSPECTION	12
ANNUAL INSPECTION	12
SINGLE SAFETY SOLENOID SYSTEM.....	14
DOUBLE SAFETY SOLENOID SYSTEM	15
SECTION VI – TROUBLESHOOTING	16
SECTION VII – MISCELLANEOUS CHARTS AND FORMULAS	17
METRIC CONVERSIONS	17

 **WARNING / CAUTION**

1. Tank is to be completely filled with water and all air is to be vented before energizing.
2. Due to the rigors of transportation, all connections should be checked for tightness before the heater is placed in operation.
3. Safety relief valve must be installed in tapping provided.
4. **KEEP AWAY FROM LIVE ELECTRICAL CIRCUITS.**
Do not perform any maintenance or replace any components inside the control panel with the high voltage power supply turned on. Under certain circumstances, dangerous potentials may exist even when the power supply is off. To avoid casualties, always turn the power supply safety switch to off, turn the charge or ground the circuit before performing any maintenance or adjustment procedure.
5. Generalized instructions and procedures cannot anticipate all situations. For this reason, only qualified installers should perform the installations. A qualified installer is a person who has licensed training and a working knowledge of the applicable codes, regulations, tools, equipment, and methods necessary for safe installation of a steam fired water heater. If questions regarding installation arise, check your local plumbing and electrical inspectors for proper procedures and codes. If you cannot obtain the required information, contact the company.

MODEL PS

OUTLINE DIMENSIONS

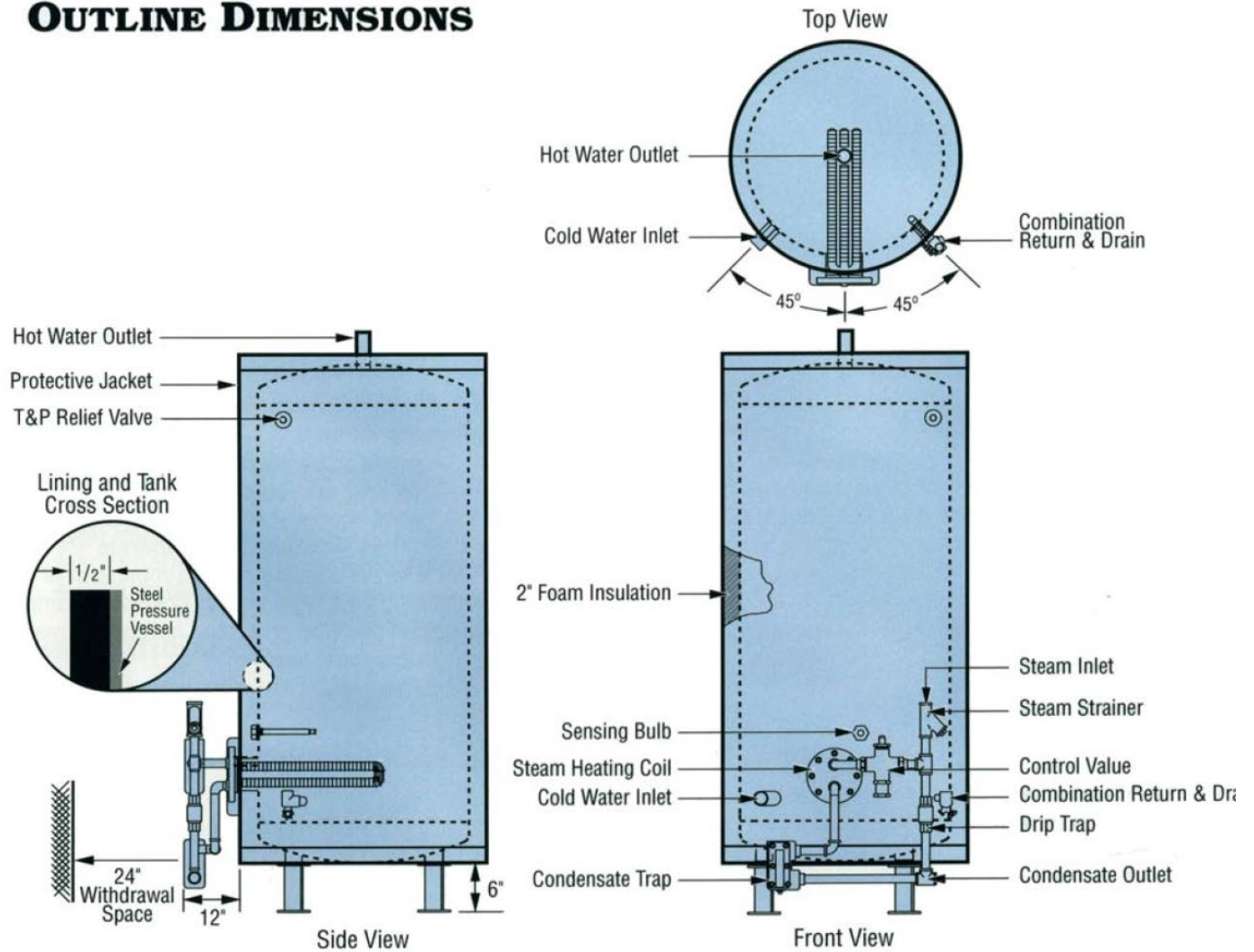

Base Model	Storage Capacity (Gallons)	Overall Diameter (Inches)	Overall Height (Inches)	Floor To: (Inches)					Shipping Weight (lbs.)
				Inlet	Outlet	Return	Relief Valve	Coil	
PS65	65	26	54	14	Top	15	46	16	325
PS80	80	26	64	14	Top	15	57	16	360
PS100	100	26	76	14	Top	15	68	16	390
PS120	120	28	76	14	Top	15	68	17	440

SECTION I - GENERAL DESCRIPTION AND CONSTRUCTION

GENERAL DESCRIPTION

This book describes a packaged steam powered water heater that is a stationary, self-contained unit.

The complete assembly on a standard unit consists of the storage tank, immersion heating coil, steam drip trap, condensate trap, steam strainer, and an ASME rated combination temperature and pressure safety relief valve. Optional equipment may be supplied with your unit. Please consult the product drawing for details specific to your assembly. The unit is factory assembled, insulated, jacketed, primed, painted, piped, tested, and ready for service connections. The maximum allowable rating for this unit is 200,000 BTU/Hr.

CONSTRUCTION

TANK

The storage tank is constructed of all welded carbon steel, and internally lined with specially formulated HydraStone cement to a ½-inch minimum thickness for superior protection and tank longevity. The tank is designed for a maximum allowable working pressure of 150 psi (225 psi TP).

TANK CONNECTIONS

The heater is supplied with separate cold water and hot water connections. Water entering the cold-water inlet is deflected by means of a baffle within the tank. A ¾-inch FNPT connection is provided for mounting a combination safety temperature and pressure relief valve. An overflow line should be utilized from the relief valve outlet to a floor drain. See the drawing specific to your unit for locations and sizes.

STEAM HEATING COIL

The water heater is supplied with a high-quality factory installed finned U-tube heating coil constructed from 7/8-inch O.D. single wall copper tubing designed for a maximum working pressure of 150 psi. The tubing is installed in a heavy-duty fabricated steel head with threaded ¾-inch MNPT steam and condensate connections. Each assembly is fastened to a corresponding tank flange using a rubber gasket "boot" and hex head steel bolts and nuts.



OUTER SHELL, INSULATION, AND SUPPORTS

The tank is encapsulated in 2-inch-thick polyurethane foam insulation. The insulation is protected by a high impact non-corroding colorized composite protective jacket. The entire vessel is supported on heavy-duty integrally welded steel supports for sturdy floor mounting.

STEAM OPERATING CONTROLS

The steam operating controls are factory selected, sized, piped, and tested to ensure reliable operation. Steam controls are shipped loose for in the field installation by others.

Steam Control Valves

A fully modulating self-contained control valve (sometimes referred to as a temperature regulator or a steam regulator) should be installed to regulate the flow of steam through the heating coil. No quick opening or snap-acting valve should be used as these can cause surges in pressure or thermal shock to the coil. The standard temperature range is 105° - 145° F. Optional ranges of 55° - 95° F, 80° - 170° F, 110° - 190° F, and 175° - 225° F are available.



Strainers

A cast iron 'Y' strainer with 20 mesh screen protects the steam controls and coil from dirt and debris in the steam supply.

Traps

Two traps should be utilized in the immediate steam piping system of the water heater. The first trap in the system is a thermostatic drip trap that is designed to collect condensate from the main steam line before entering the control valve. Additionally, a main condensate cast iron float and thermostatic trap should be located in the condensate line after the steam coil. This trap ensures that the steam remains in the coil and releases its energy before exiting the coil and traveling down the condensate line.

OPTIONS

The following optional features may be included in your water heater. Reference included drawing specific to your heater for further details.

Single Solenoid Safety System

A single solenoid safety system closes the steam supply to the control valve should the temperature in the tank reach the high limit set point. This option requires 120-volt, 5-amp electrical service.

Double Solenoid Safety System

A double solenoid safety system dumps over heated water in the storage tank to drain in addition to closing the steam supply to the control valve. This option requires 120-volt, 5-amp electrical service.

Backup Electric Heating Elements

Backup electric heating elements may be installed in various wattages and voltages to heat the water when the steam supply is turned off.

Circulating Pump Package An intra-tank circulation pump package with On/Off switch to continuously circulate water within the tank and thereby reduce stratification may be installed. An all-bronze circulator pump, rated 1/25 HP, 120V, 1Ph, is used.

Dial Temperature and Pressure Gauge

A combination temperature (70° - 270° F) and pressure (0 – 200 psi) gauge with 3-inch dial may be factory installed in the tank.



Steam Pressure Reducing Valve

An optional steam pressure reducing valve, to reduce the steam supply pressure to the control valve, may be included.

Double Wall Heating Coil

A Double Wall Heat Exchanger consists of two copper tubes, one inside the other, wound into a coil. The outer tube is soldered into the fitting that mates into the tank. The inner tube is soldered into the fitting that mates with the hot water supply. The gap between the two tubes is open to the air, allowing visible detection of any leaks, as well as preventing any leaks from mixing into the other liquid.

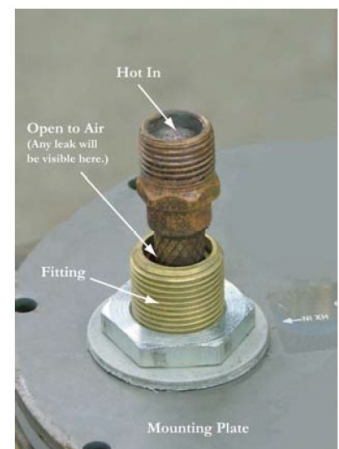

SECTION II – INSTALLATION



DO NOT TURN ON THE STEAM SUPPLY to this equipment until the heater is completely filled with water and all air has been released. *If the heater is NOT filled with water when the steam supply is turned on, damage to the heating coil may result.*

For protection against excessive pressures and temperatures, local codes require the installation of a temperature-and-pressure (T&P) relief valve certified by a nationally recognized laboratory that maintains periodic inspection of production of listed equipment of materials, as meeting the requirements for Relief Valves and Automatic Gas Shutoff for Hot Water Supply Systems. ANSI Z21.22-1971. THE CUSTOMER IS RESPONSIBLE TO PROTECT PROPERTY AND PERSONNEL FROM HARM WHEN THE VALVE FUNCTIONS.

All water heaters have a risk of leakage at some unpredictable time. IT IS THE CUSTOMER'S RESPONSIBILITY TO PROVIDE A CATCH PAN OR OTHER ADEQUATE MEANS, SO THAT THE RESULTANT FLOW OF WATER WILL NOT DAMAGE FURNISHINGS OR PROPERTY.

Never operate unit in excess of design conditions.

The tank should be fully drained in the event the steam has been turned off and if there is danger of freezing.

WATER HEATER PLACEMENT

1. Place the heater on a solid foundation in a clean, dry location nearest to the point of most frequent hot water use. If the heater is to be raised off the floor, the entire bottom of the heater should be supported by a solid surface.
2. Adequate space should be provided for removal of the heating element.
3. Unit should be level to permit proper drainage.

INSTALL THE HEAT EXCHANGER COIL

1. Remove the access panel.
2. Apply the included O-ring lubricant to O-rings.
3. Insert the O-rings into the grooves on the plastic O-ring housing.
4. Insert heat exchanger and align holes in cover plate with holes in flange.
5. **WARNING: Plastic O-ring housing must be properly installed. Failure to do this will void the warranty.**
6. Insert and secure the bolts to the nuts one at a time in the following manner:
 - Place the nut behind the flange opening.
 - Hold the nut in place with one hand – insert the bolt with washer with the other.
 - Thread the bolt through the washer and into the nut and tighten.
 - **NOTE: Be sure to place bolts in all the openings.**

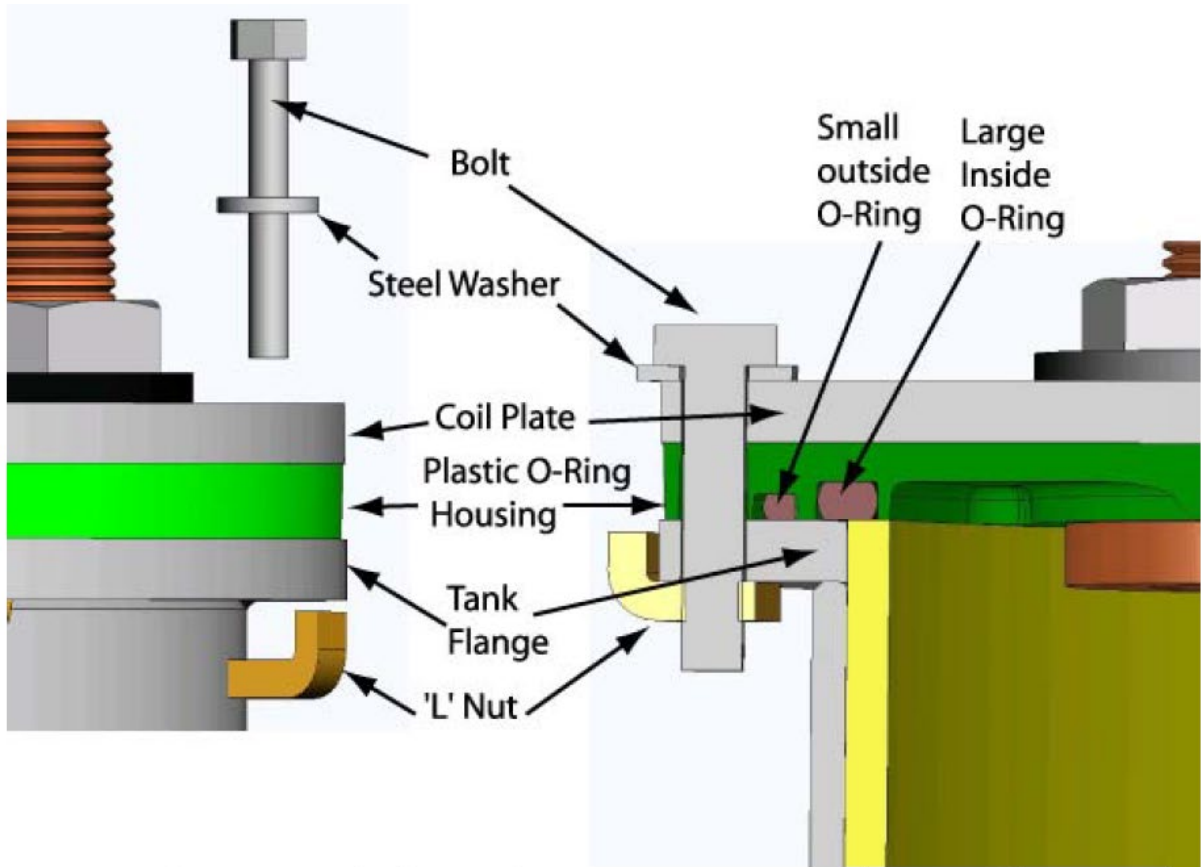

Proper tightening sequence for coil

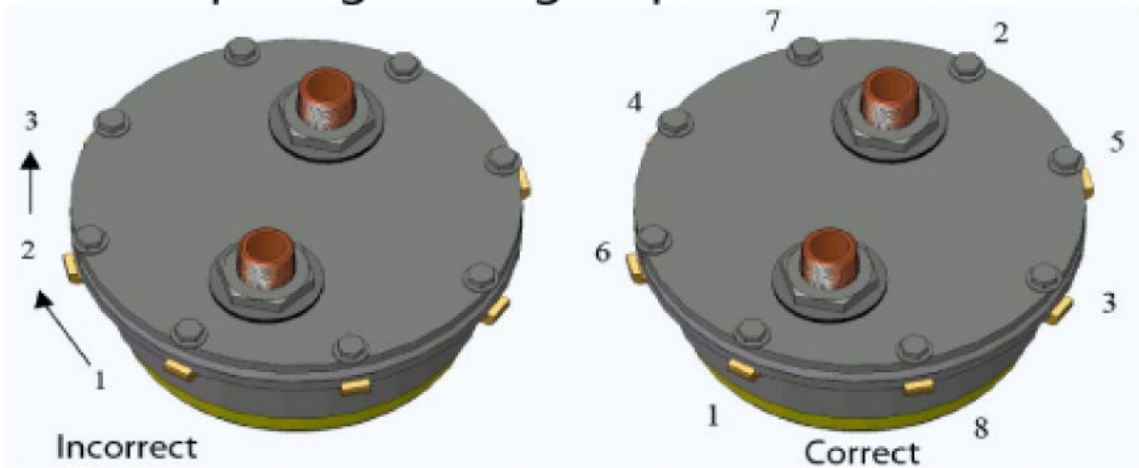

Note:- Same as car tire lugs

Caution: Does not require excessive force to seal properly.

PIPING INSTALLATION

NOTE: The most effective means for preventing deterioration from accelerated corrosion due to galvanic and stray current is the installation of dielectric fittings/unions. The installation of these fittings is the responsibility of the installation contractor.

1. All integral components have been properly sized to meet design conditions. Piping to the unit should not be smaller than the size of pipe connections furnished by Hubbell.
2. Install the heating coil in the mating flange using the rubber boot gasket, nuts, bolts, and inserts as supplied. Install the coil with the steam Inlet/Condensate Outlet connections in the most vertical position (12 o'clock and 6 o'clock).
3. If the steam components are factory pre-piped, assemble the piping to the unions as shown in the drawing. If the steam components are shipped loose, pipe them as shown in the drawing.
4. Install the bulb of the control valve in the tapping provided.
5. Steam supply should be piped to the steam inlet strainer. Condensate outlet should be piped to your condensate line.
6. Condensate lines must be run downhill to get proper drainage. A condensate pump can be used if it is impossible to run the line downhill . If there is adequate steam pressure, this may push the condensate uphill, 1 psi steam will lift condensate 1 foot.
7. Install the combination temperature and pressure safety relief valve in the tapping provided. Note that this is required by law for safety considerations.

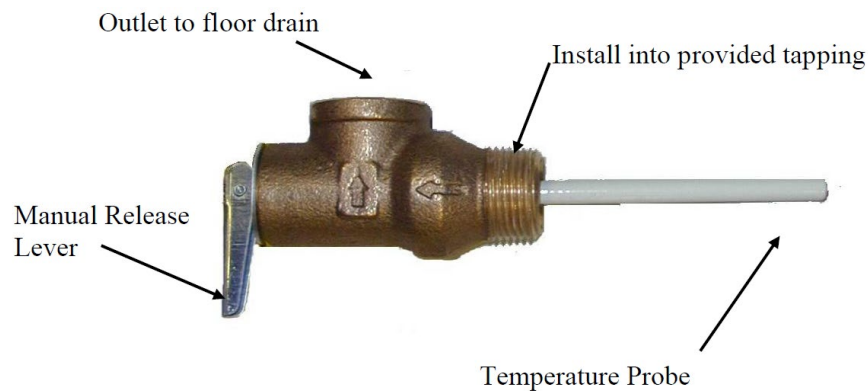

Install a relief valve overflow pipe to a nearby floor drain. CAUTION: No valve of any type should be installed between the relief valve and tank or in the drain line.

ELECTRICAL INSTALLATION

1. Refer to the Hubbell drawing for any electrical requirements.
2. Enter electric enclosure with properly sized feeder leads. Install these power leads into the box lugs on the terminal block or magnetic contactor.
3. All other electrical connections are made at the factory; therefore, no other electrical connections are necessary.

FILLING THE HEATER

1. Begin with all steam, condensate, and water valves closed. Open the isolation valves on the integral circulator line, if supplied.
2. Open cold-water valve, fill unit with cold water. Lift lever on relief valve to relieve trapped air. Release relief valve lever when all traces of air have been vented from the unit. Leave cold water valve open.

SECTION III – INSTALLATION AND OPERATION OF STERLCO TEMPERATURE CONTROL VALVES

WARNING / CAUTION

HANDLE GENTLY. Temperature control valves are instruments, not pipe fittings. A dent in the body or a sharp bend in the capillary may prevent them from operating. Do not use pipe wrenches. Do not subject controls to water-hammer conditions or excessive pressures.

BULB LOCATION

This is perhaps the most important factor in good installation. The entire bulb, not just part of it, must be exposed to the fluid of which the temperature is to be controlled. In a tank, it must be in a representative location not in a corner which may be warmer or cooler than the rest of the tank. The temperature at the bulb is the only one which can be controlled.

VALVE LOCATION (HEATING OR DIRECT ACTING CONTROL)

In supply line close to inlet. When heating with steam always use a float and thermostatic trap at the condensate outlet from the heating equipment. Do not install the control valve at the condensate outlet; water-hammer or poor control may result.

VALVE POSITION

Preferably with adjusting screw at top but can usually be used in any other position. If possible, let capillary run downward from valve to bulb. All valve bodies have arrows showing direction of flow. If installed backward, they will be noisy or inoperative.

CAPILLARY LOCATION

Not next to a steam line or in a cold draft. If the capillary is exposed to extreme temperatures, it may be desirable to wrap it with insulating material.

STRAINERS

A 'Y' Strainer should always be installed just ahead of the control valve to protect it from large particles of dirt and the system must be kept free of sediment, scale, etc.

ADJUSTMENT

Temperature adjustment within the range of the control is made by simply turning an adjusting screw in the direction indicated on the valve body or nameplate. Turn the screw only a little at a time, then let temperatures reach equilibrium before adjusting further.

OPERATION

Remember that this is a modulating control. It does not alternately open wide and shut tight like an electrical control device. Rather, it opens gradually wider and wider in relation to the difference between the actual bulb temperature and the bulb temperature at which the valve is closed. In normal operation, the control valve remains in a constant, partially open position which is automatically adjusted whenever conditions require it.

MAINTENANCE

The only service normally required is to keep the control clean. The valve can be inspected and cleaned by access through the inlet and outlet, without disassembly. The bulb must not become coated with any substance which interferes with the transmission of heat.

If repairs are needed, we recommend that these controls be returned to our factory for reconditioning. Skilled workmen, with proper tools, replacement parts, and testing facilities will do a good job more economically than it can be done in the field. These controls are simple to disassemble and assemble for a person who is familiar with them. An inexperienced worker will sometimes damage them by incorrect handling, and usually replacement parts, which are not

available in the field, will be required. If for any reason it is necessary to disassemble one of these controls, please write to us for detailed assembly drawings and instructions.

If a control must be returned for repairs, please tell us as much as possible about what appears to be wrong and ship it "as is" without disassembling it and possibly damaging good parts. This will help us to do the best and most economical work, and to advise you how to avoid further trouble.

TROUBLESHOOTING

If the control does not appear to be holding temperature steady, or if not enough heating or cooling is obtained, first check for external conditions which may prevent the control from operating correctly. Examples are: low or fluctuating steam or water supply pressure; damaged or obstructed valves, traps, strainers or other accessories; supply piping too small; dirty bulb or poor bulb location.

If the valve will not close, check for dirt or foreign matter between disc and seat. The valve can be inspected through the inlet and outlet openings without disassembly and can usually be cleaned out with an air hose.

If overheating results because a direct-acting (heating) valve stays open or a reverse-acting (cooling) valve stays closed regardless of the temperature at the bulb, the thermostat may have lost its fill and become inoperative. To check this, remove valve and bulb from the line, set the control at about the middle of the range, and insert the bulb in water hotter than the maximum of the range. If the direct-acting control does not close or the reverse-acting control does not open, factory repairs to the thermostat are required.

If there is a leak to the exterior of the body, some part may be loose or partially disassembled. Otherwise, a seal bellows may be damaged requiring factory replacement.

If the valve chatters, this usually means a loose or disassembled interior part. Chattering is sometimes caused by other devices near the control, and can sometimes be eliminated by changing piping arrangements, valve position, or supply pressure.

Typical Sterlco Control Valve

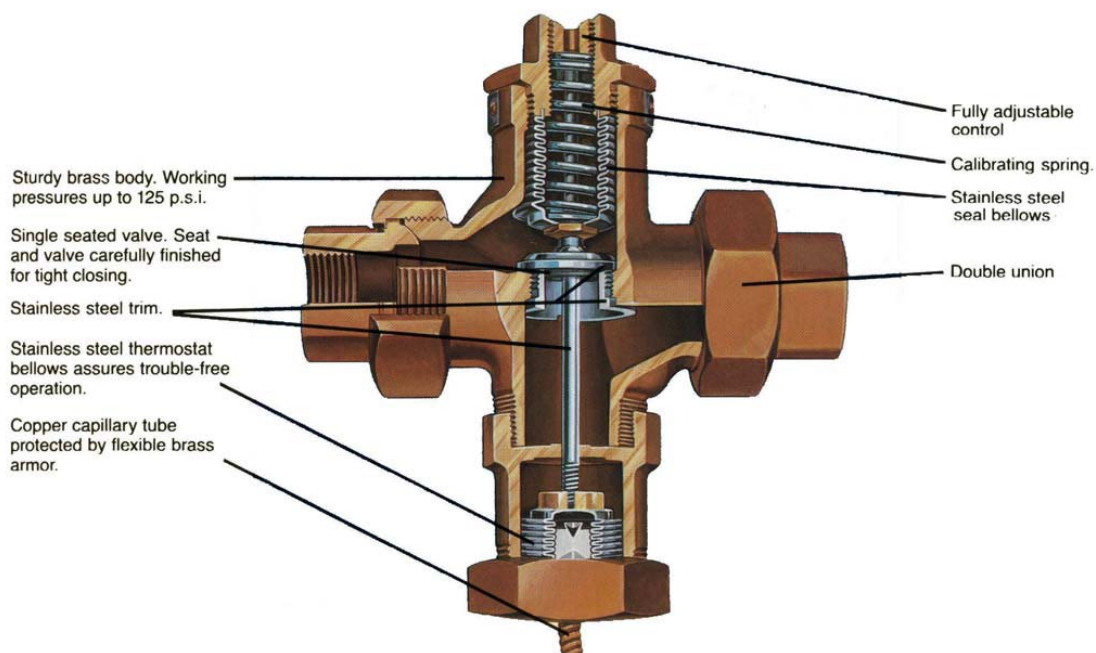

SECTION IV – OPERATION

STARTUP

1. Begin with all steam, condensate & water valves closed.
2. On systems with a factory supplied intra-tank circulation pump, open the two gate valves.
3. Fill the unit with cold water. Lift lever on relief valve to relieve trapped air. Release valve lever when all traces of air have been vented from the unit. Leave cold water valve open.
4. Turn pump switch to the "On" position.
5. Set the control valve to the desired temperature. Please see Section III for details on the control valve. There is no temperature indicator on the control valve. Rather, by turning the calibrating screw on the top of the valve clockwise you increase the temperature and by turning it counterclockwise you lower the temperature.
6. If the unit has a solenoid safety system, set high-limit thermostat to desired temperature. (This thermostat must be set at a higher temperature than the control valve setting, or the unit will continually go off on high-limit and will never reach the desired temperature.)
7. Gradually open valve to allow steam to enter the heating coil. Monitor the tank temperature until the desired temperature is reached. If the control valve shuts off before the desired temperature is reached or if overshoot occurs, adjustment of the control valve will be required. Adjust the calibrating screw clockwise for hotter water and counterclockwise for colder water temperatures.
8. After the unit has reached the desired temperature, and adjustments have been made, open gate valve on the hot water outlet and the building recirculation line.
9. Gaskets may require tightening after water is heated.
10. **Never** operate unit in excess of design conditions.
11. **Never** break any joint, (gasketed or screwed), until the pressure in the unit has been reduced to zero and the unit drained.

SHUTDOWN

1. Close entering steam valve.
2. Close hot water outlet.
3. Close building recirculation line.
4. Close cold water inlet.
5. Turn intra-tank circulation pump OFF.
6. The unit can be drained at this point. (1) Lift lever on relief valve to vent tank. (2) Open drain valve.

SECTION V – SCHEDULED MAINTENANCE AND SERVICING

WARNING / CAUTION

Before performing any maintenance procedure, make certain steam supply and electrical power supply is **OFF** and cannot accidentally be turned on.

QUARTERLY INSPECTION

1. Monitor thermostat.
 - a. Let the water heater completely heat to a designated thermostat setting.
 - b. After the thermostat satisfies (that is, when the thermostat actually clicks off), draw water from heater.
 - c. Compare the water temperature of drawn water to the temperature setting of the thermostat when it satisfies. Normal variation between the two points is approximately $\pm 5^{\circ}\text{F}$.
 - d. If these two readings do not coincide within acceptable tolerances and verification has been made of the accuracy of the temperature-reading gauge, replace the thermostat.
2. Lift test lever on relief valve and let water run through valve for a period of approximately 10 seconds. This will help flush away any sediment that might build up in water passageways.

ANNUAL INSPECTION

1. Units subject to fouling or scaling should be cleaned periodically. A marked increase in pressure drop and/or reduction in performance usually indicates cleaning is necessary.
2. To clean inside of tubes, remove all heads and covers. (**Caution: Do not loosen heads until you are sure all pressure is off the equipment, and the unit is drained.**)
3. In cleaning a tube bundle, tubes should not be hammered on. If it is necessary to use scrapers, care should be taken to ensure that the tubes are not damaged.
4. Before it is necessary to apply mechanical means for cleaning, try to clean the unit using the following methods.
 - a. Circulate hot fresh water at a reasonable velocity.
 - b. Try spraying with a water hose.
 - c. Consult with manufacturers of cleaning compounds and chemicals. They will check the nature of the deposit, recommend the right cleaning compound, and in many cases provide equipment and personnel for a complete cleaning job.
5. Do not clean tubes by blowing steam through individual tubes.
6. If the unit is dismantled for any reason, it should be reassembled using new gaskets.
7. Do not tighten bolts until gaskets are properly seated.
8. When tightening bolts in the element head, tighten the bolts in a crisscross pattern. This will evenly distribute pressure around the flange and help prevent warping. See diagram below.
9. Convection packages may be equipped with an integral circulator. This circulator should be serviced per the enclosed pump O&M manual.
10. Packing on valves and regulators should be checked for leaks and repaired or replaced as necessary.

11. Drain and flush tank as follows. Perform annually or more often , if required.
 - a. Shut down unit as described in Section II.
 - b. Close valve on hot water outlet piping.
 - c. Open valve on drain piping.
 - d. Cold water inlet line pressure will be strong enough to flush sediment from the bottom of the tank out through the drain. Let the water run for 3-4 minutes.
 - e. Clean strainer filter, see below.
 - f. Close drain valve.
 - g. Open hot water valve.
 - h. Re-start unit as described in Section II.
12. Clean strainer filter. Perform annually or more often , if required.
 - a. Remove blowoff bushing (E) or cap (F), as required.
 - b. Remove gasket (B), if required.
 - c. Remove, clean, and re-install screen (A).
 - d. Replace gasket (B).
 - e. Re-install blowoff bushing (E) or cap (F), as required.

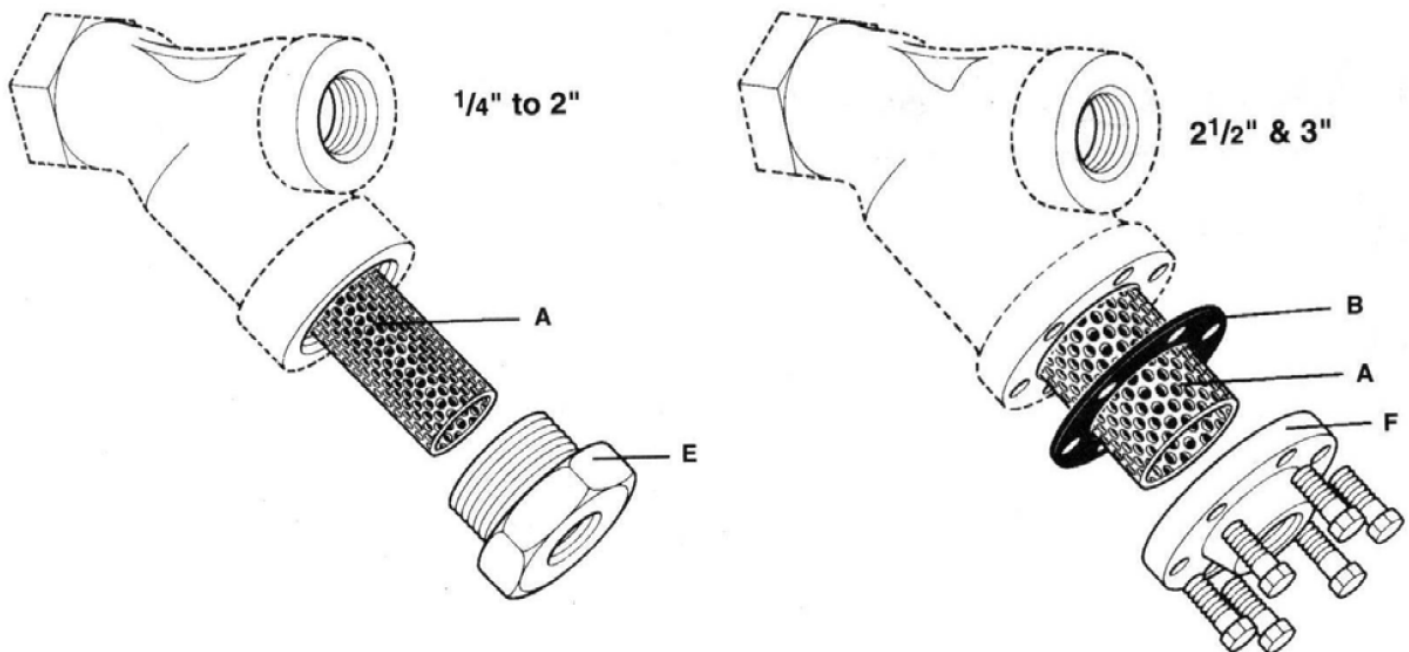

SINGLE SAFETY SOLENOID SYSTEM (if installed)

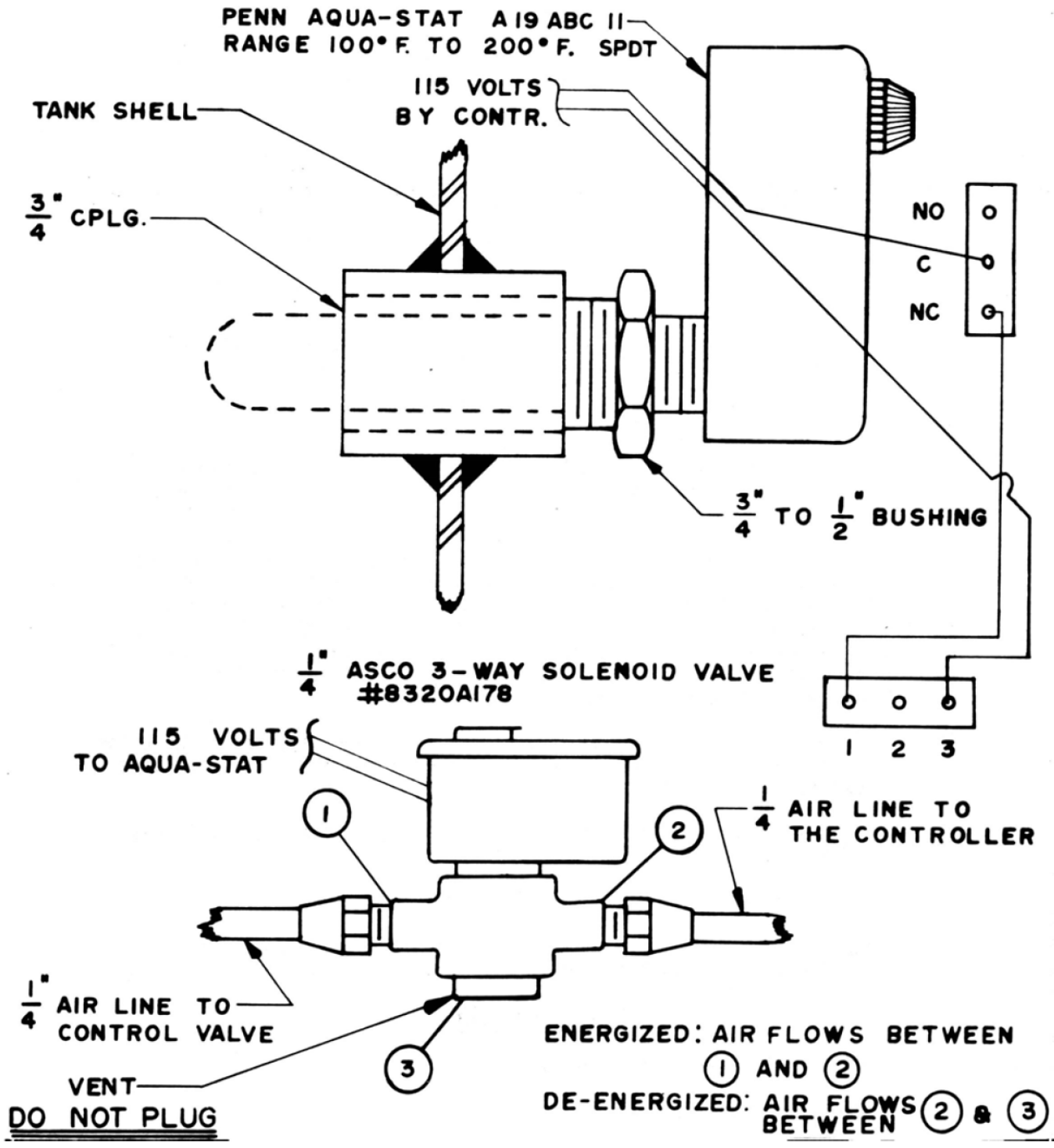

DOUBLE SAFETY SOLENOID SYSTEM (if installed)

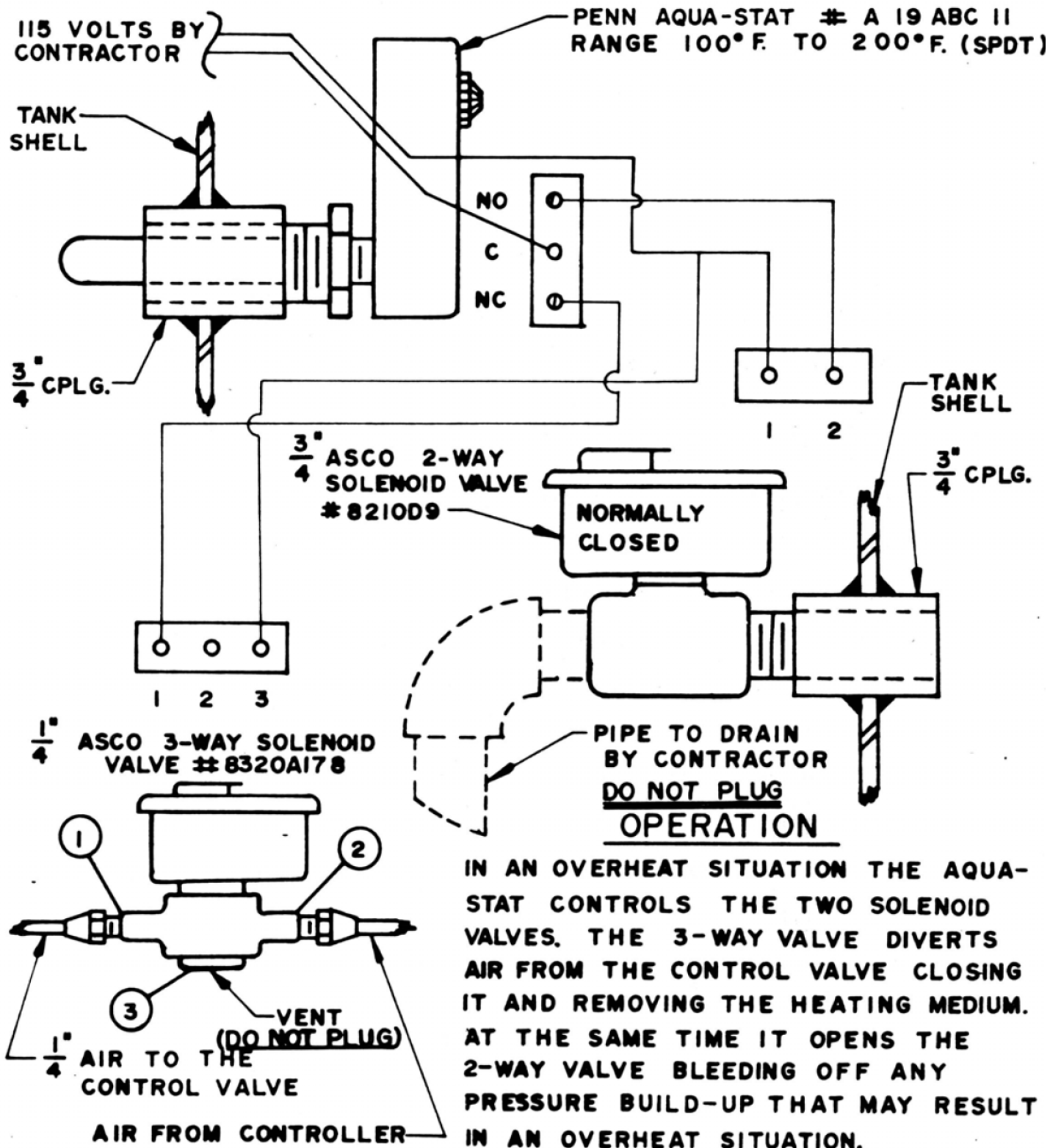

SECTION VI – TROUBLESHOOTING

Symptom	Probable Cause	Corrective Action
Gradual loss of heating capacity.	Tubes are fouled.	Clean tubes per Section V, annual scheduled maintenance.
	Excess silt in bottom of tank.	Drain and flush tank per Section V , annual scheduled maintenance.
	Strainers clogged.	Clean strainers per Section V, annual scheduled maintenance.
	Pump impellor deteriorated.	Repair or replace per separate O&M.
Overheating.	Temperature regulator has lost its charge, self contained valves only.	Repair or replace per separate O&M.
	Ruptured tube(s) in heating coil.	Remove / replace heating coil.
	Temperature regulator needs adjusting.	Adjust temperature regulator per Section IV.
	Circulator not operating.	Repair or replace per separate O&M.
	Debris under seat of temperature control valve.	Repair or replace per separate O&M.
	Capillary tube pinched on temperature control.	Repair or replace per separate O&M.
Immediate loss of heating capacity.	Capillary tube pinched on temperature control.	Repair or replace per separate O&M.
	Defective steam trap.	Repair or replace per separate O&M.
	Blockage in condensate line.	Clean blockage from condensate line.
	Loss of steam pressure to temperature regulator.	Check steam pressure to temperature regulator. Verify that it is within limits. Adjust as necessary.
Excessive vibration.	High rate of flow beyond design conditions.	Consult factory.
	Under sized piping to the unit.	Re-pipe lines to unit using proper sized lines.
Water hammer.	Defective steam trap.	Repair or replace per separate O&M.
	Undersized condensate lines.	Re-pipe condensate line using proper sized lines.
	Insufficient slope on condensate lines causing backup.	Increase slope on condensate lines.

* **Red symptom** indicates that equipment should be shut down immediately and cause of malfunction corrected before unit is re-started or serious damage may result.

SECTION VII – MISCELLANEOUS CHARTS AND FORMULAS

METRIC CONVERSIONS

Liters x 0.2641 = Gallons	Bar x 14.5 = psi
Gallons x 3.79 = Liters	psi x 6.86 = kPa
Gallons x 0.003785 = m ³	kPa x 0.1456 = psi
m ³ x 264.2 = Gallons	Lbs x 0.4536 = Kg
1°C ΔT = 1.8°F ΔT	Kg x 2.2 = Lbs
°F = (°C x 1.8) + 32	ft ² x 0.0929 = m ²
°C = (°F - 32) x 0.556	m ² x 10.765 = ft ²
psi x 0.06896 = Bar	

HUBBELL ELECTRIC HEATER COMPANY
45 SEYMOUR STREET
STRATFORD, CT 06615

PHONE: (203) 378-2659
FAX: (203) 378-3593
Hubbellheaters.com