

ASME Packaged Electric Water Heater

15–1600 kW all voltages and phases, 80–10,000* gallon capacity, highly customizable

HydraStone™ cement lining provides superior protection and tank longevity

Heavy duty construction withstands demanding commercial/industrial use

All electrical operating controls are factory selected and wired to ensure reliable operation

- Designed and built to customer specifications
- Only high-grade materials used in construction to ensure long operating life
- Fully packaged water heater saves time and money during installation
- Full range of styles, sizes and optional features to meet your exact water heating needs
- Dual Fuel available: steam, gas, boiler water
- Highly efficient design lowers peak power demand and reduces operating costs

Applications

Schools, office buildings, prisons, stadiums, hotels, industrial facilities, nursing homes, hospitals and more.

*Larger capacities available



SIGNATURE SERIES
SH/H

A heavy duty storage electric water heater

The Signature SH/H is a fully packaged water heater designed to be a reliable and long-lasting source for hot water. Each component is carefully selected to ensure performance in even the most demanding application. Whether you are heating potable water in a commercial building or heating process water in an industrial application you can select a Hubbell Signature SH/H to do the job.

Over 100 years of water heating expertise

Hubbell water heaters are the right choice for your commercial and industrial applications. We have water heating solutions for most energy sources with storage capacities from 1–10,000 gallons — all designed, engineered, and manufactured for reliability and longevity coupled with unparalleled support and service.

NOTE: Manufactured in an ISO 9001:2015 facility.
BABA & BAA compliance is available upon request.



Meets the requirements of the ASME
Boiler and Pressure Vessel Code



The Difference: HydraStone™ Cement Lining

Cement lined tanks offer significant longevity, trouble-free operation and a lower lifetime cost.

The type of protective lining is the single most important feature when determining the quality of any water heater. The ability of a lining to protect the steel tank is primarily based on its thickness and complete coverage of all steel surfaces.

A glass lined tank uses only $\frac{5}{1000}$ inches of glass (the thickness of a sheet of paper) which does not cover all internal surfaces. To compensate, all glass lined tanks require a sacrificial anode rod which must be periodically inspected and replaced.

Our tanks are lined with a minimum of $\frac{1}{2}$ inches of high density HydraStone cement – 100 times thicker than glass lining. Full coverage is achieved by injecting the precise amount of HydraStone cement into each tank and then centrifugally spinning it at 250 RPM to ensure complete and uniform coverage. This process provides maximum protection from the corrosive effects of hot water. Additionally, cement lined tanks do not require a sacrificial anode, eliminating periodic inspections and replacement costs associated with glass lined tanks.

Our water heater tanks are constructed with solid non-ferrous stainless steel tank tappings which are impervious to the corrosive effects of hot water. Glass-lined tanks have regular steel tappings which are vulnerable to corrosion.

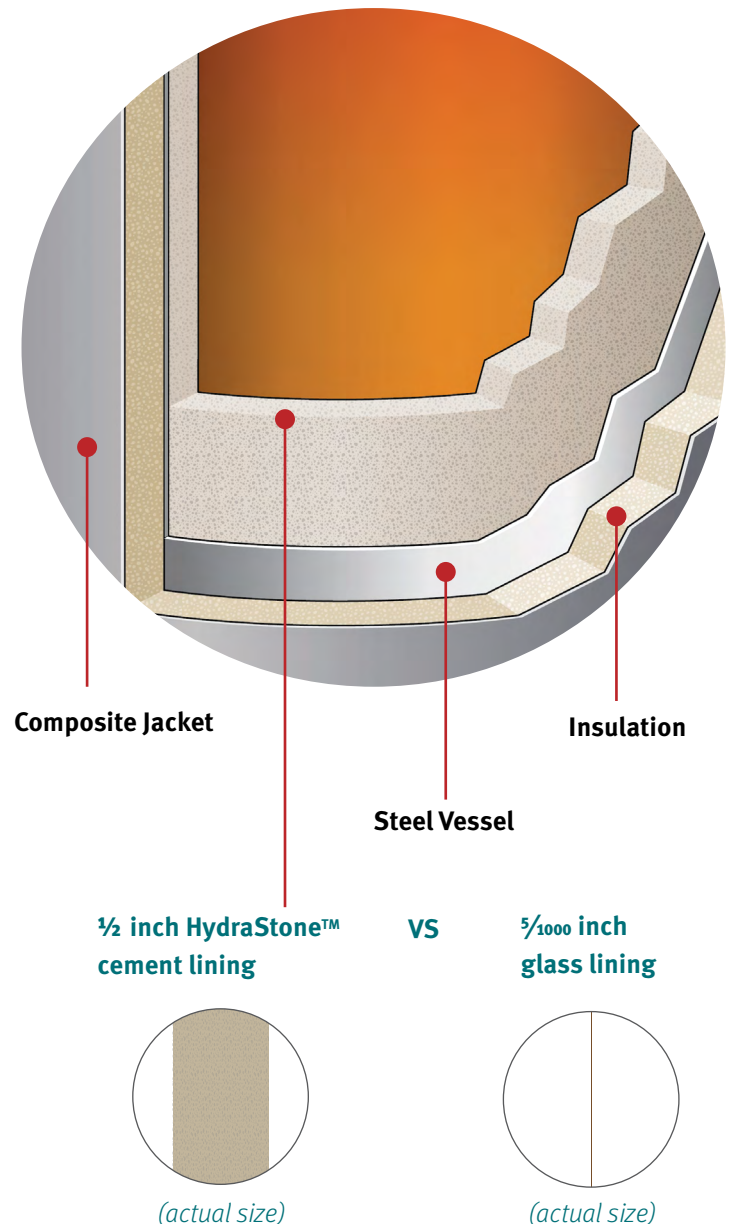

Standard Equipment

GENERAL

Pressure vessels 500 gal or less come with 2" thick polyurethane foam insulation, and a composite jacket. Stainless steel vessels 500 gal or less come with 2" thick fiberglass and galvanized jacket

Pressure vessels greater than 500 gal come with 3" fiberglass insulation and a stainless steel jacket

Entire vessel is supported on heavy duty integrally welded steel supports for sturdy floor mounting

Full five (5) year Non Pro-Rated tank warranty and one (1) year electrical component warranty

Bronze ASME rated combination temperature and pressure safety relief valve set at the vessel working pressure and 210°F

VESSEL CONSTRUCTION

All welded carbon steel vessel designed and built in strict accordance with the ASME Code and stamped, certified and registered with the National Board of Boiler and Pressure Vessel Inspectors

All internal tank surfaces are lined with a minimum of 1/2" thick HydraStone cement for superior protection and tank longevity

Designed for 150 psi working pressure and hydrostatically tested at 225 psi (1-1/2 times the WP)

ELECTRICAL OPERATING CONTROLS

All electrical operating controls are factory sized, selected, wired, tested and mounted in a NEMA 1 enclosure to ensure safe and reliable operation

A power distribution block is supplied for single point electrical connection

Power fuses rated at a maximum of 60 Amps protect each heating element branch circuit per NEC and UL requirements. Each branch circuit has a maximum rating of 48 Amps

Heavy duty definite purpose magnetic contactor with integrally mounted power fuse block assembly switches power on/off to each branch circuit

Fully adjustable thermostat maintains accurate water temperature and is sized by the factory to control the appropriate number of heating element circuits

A transformer provides fused 120V to the control circuit

A fully adjustable (100-240°F) immersion safety hi-limit device with manual reset interrupts power to the control circuit in the event of over-temperature water in the storage tank

Safety door interlock mechanism interrupts power to the control circuit upon opening the electrical control panel

Dimensions

Vertical Standard

The Hubbell Signature SH comes standard with Grouped Screw Plug Elements

Sample drawing is for a SH200-o-8oSST4

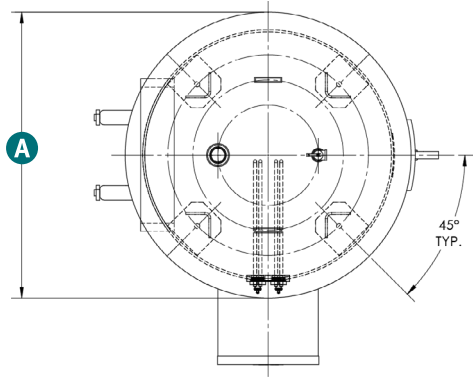

TOP VIEW

Storage Capacity	Dimensions (Inches)					
	Diameter "A"	Height "B"	Vessel Diameter x Length	Nominal Storage Capacity (Gallons)	Inlet Outlet Sizing (NPT)	Approx. Shipping Weight (Lbs.)
80*	26	64	22 x 54	90	1 ½	700
120*	28	75	24 x 65	130	1 ½	900
200	34	82	30 x 72	220	1 ½	1700
250	40	74	36 x 64	285	1 ½	1850
400	46	85	42 x 75	450	1 ½	2700
600	52	95	48 x 85	665	2	3650
800	52	119	48 x 109	850	2	4300
1250	58	149	54 x 139	1380	2	5600

*Below 200 gallons, tanks do not come equipped with a manway. Please consult factory if desired on these sizes.

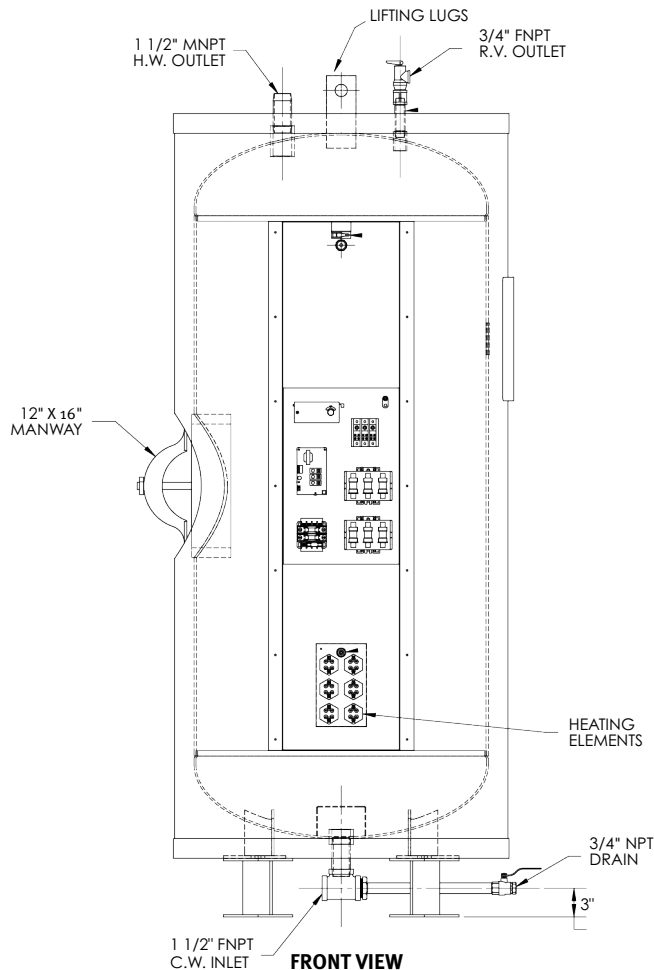

FRONT VIEW

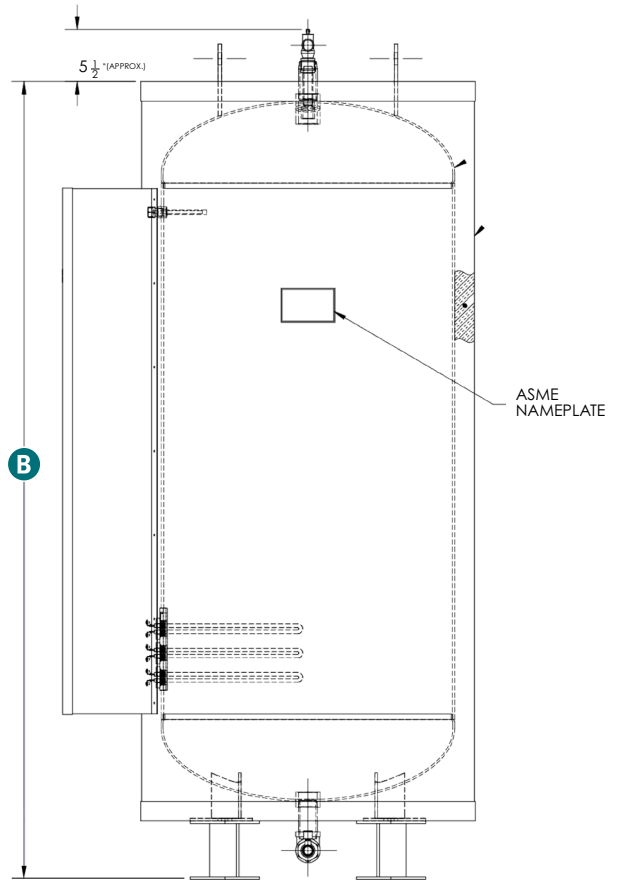

RIGHT SIDE VIEW

All information is subject to change without notice. Consult factory for submittal drawings.

kW and Amperage Selection Chart for Standard Grouped Screw Plug Elements

3 Phase Voltages						
kW	208	240	415	440	480	600
4			6.3			
5				6.6		
6	16.7	14.4			7.2	6.0
7			12.5			
8				9.9		
9	25.0	21.7	9.3		10.8	9.0
10				13.2		
11			15.6			
12	33.3	28.9			14.4	11.3
13			18.6	16.5		
14			18.8			
15	41.6	36.1		19.8	18.0	14.7
17			23.4			
18	50.0	43.3	24.9		21.7	
19				24.8		18.0
20			28.0			
21						20.0
22			31.2			
23					27.1	
24	66.6	57.7				
25				32.3		24.1
27			37.4			
28						27.1
29					35.2	
30	83.3	72.2	41.5	39.7		29.3
34			46.7	44.0		
36	99.9	86.6	49.9		43.3	
38				49.6		36.1
40			56.2		48.0	
42						40.0
44			60.8			
45	124.9	108.3	62.5	59.5	54.1	
48	133.2					
49				64.5		
50			70.1			48.1
54		129.9	74.8		65.0	
56			78.0			54.1
59					70.4	
60	166.5	144.3	82.9			
61				79.4		
62						60.0
67			93.5	88.0		
72		173.2			86.6	
74				96.8		
75	208.2					72.2
80					96.0	

3 Phase Voltages						
kW	208	240	415	440	480	600
81			112.3			
83						80.0
84			117.0			
87			121.6			
88					105.5	
90	249.8	216.5	124.5			
91				119.1		
100						96.2
101			140.4	132.0		
108		259.8			129.9	
109			152.1			
117		281.5				
120					144.0	
121			168.5	158.8		
125						120.3
131			182.4			
134				176.0		
135			187.1			
144					173.2	
149			207.4			
150						144.3
151				198.5		
160					192.0	
162			224.7			
168				220.0		
179			248.9			
180					216.5	
182				238.2		
200					240.0	
201				264.0		
216					259.8	
239					288.0	
300					361.3	
350					421.5	

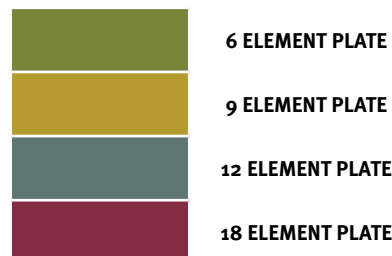

All information is subject to change without notice. Consult factory for submittal drawings.

Dimensions

Vertical Custom Made

The Hubbell Signature SH is a highly customizable water heater. We utilize flanged elements for custom orders, speak with a Hubbell Sales team member to the dimensions for your needs.

Sample drawing is for a SH1250-0-30SLT4-V27-G25

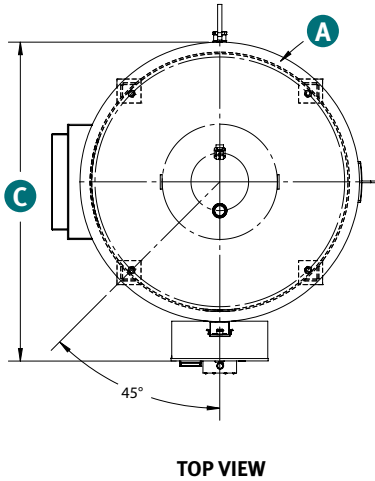

Storage Capacity	Dimensions (Inches)					
	Diameter "A"	Height "B"	Vessel Diameter x Length	Nominal Storage Capacity (Gallons)	Inlet Outlet Sizing (NPT)	Approx. Shipping Weight (Lbs.)
80*	26	64	22 x 54	90	1 ½	700
120*	28	75	24 x 65	130	1 ½	900
200	34	82	30 x 72	220	1 ½	1700
250	40	74	36 x 64	285	1 ½	1850
400	46	85	42 x 75	450	1 ½	2700
600	52	95	48 x 85	665	2	3650
800	52	119	48 x 109	850	2	4300
1250	58	149	54 x 139	1380	2	5600

*Below 200 gallons, tanks do not come with a manway. Please consult factory if desired on these sizes.

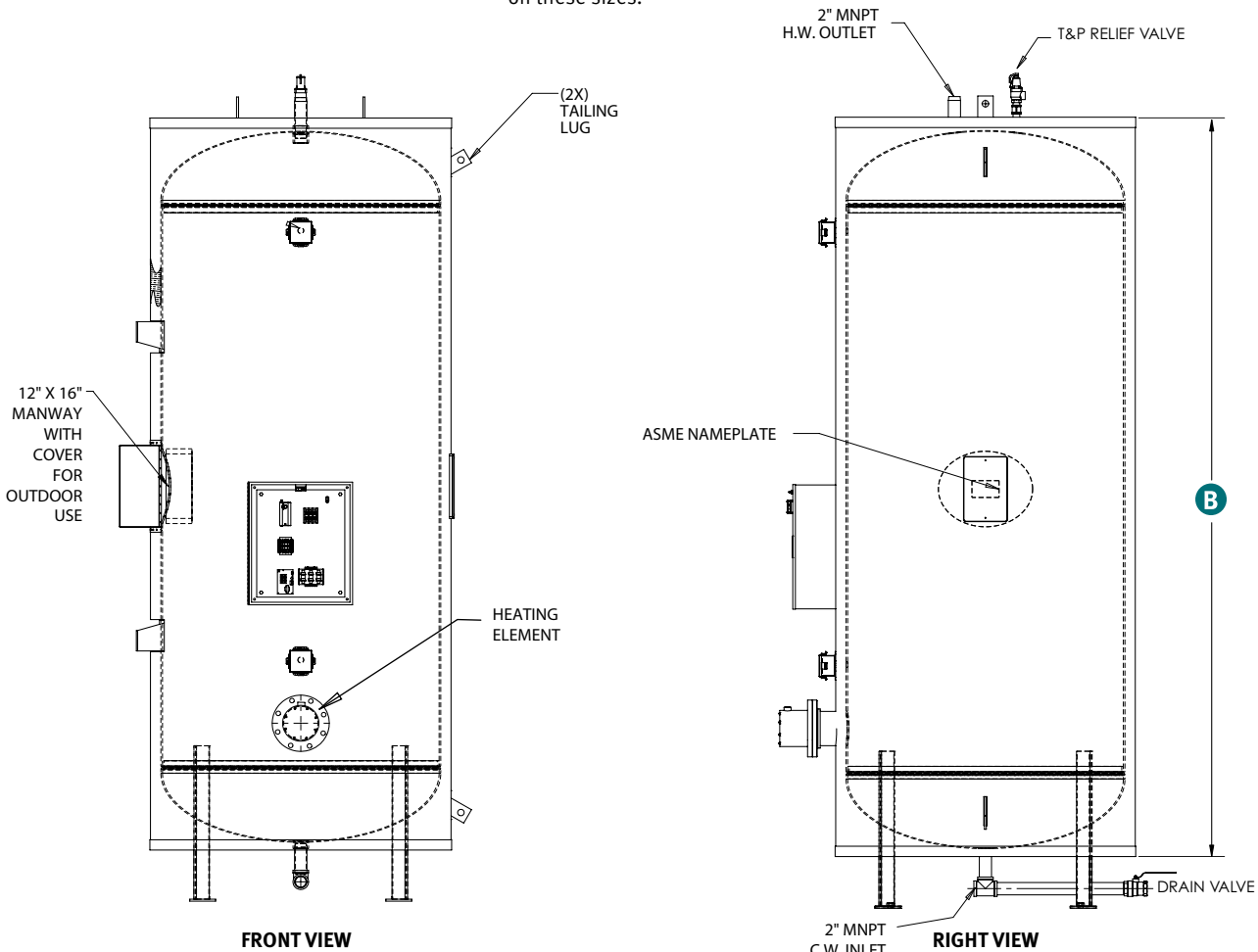

All information is subject to change without notice. Consult factory for submittal drawings.

Dimensions

Horizontal Custom

Custom horizontal Signature H models use flanged elements.

Sample drawing is for a H1250-0-234SLT4-V5

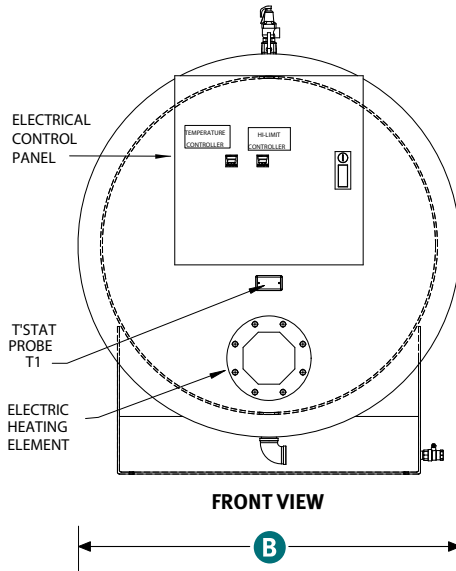

Storage Capacity	Dimensions (Inches)					
	Length "A"	Width "B"	Height "C"	Nominal Storage Capacity (Gallons)	Inlet Outlet Sizing (NPT)	Approx. Shipping Weight (Lbs.)
80*	70	26	32	90	1 1/2	700
120*	81	28	34	130	1 1/2	900
200	86	34	40	220	1 1/2	1700
250	78	40	46	285	1 1/2	1850
400	89	46	52	450	1 1/2	2700
600	98	52	58	665	2	3650
800	123	52	58	850	2	4300
1250	153	58	64	1380	2	5600

*Below 200 gallons, tanks do not come with a manway. Please consult factory if desired on these sizes.

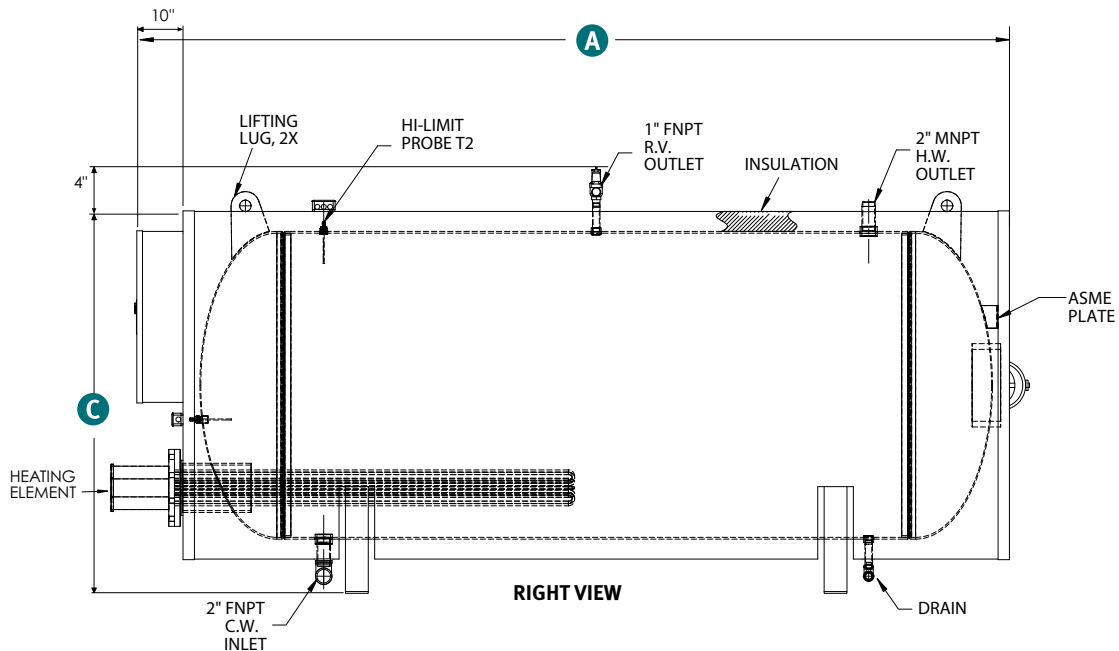

All information is subject to change without notice. Consult factory for submittal drawings.

Sizing Information Variables to Solve For

Solve for the unknown using the formulas below.

kW Requirement:

$$\text{_____ GPH} \times \text{_____ }^{\circ}\text{F}\Delta\text{T} \times 0.00244 = \text{_____ kW}$$

Temperature Rise:

$$\text{_____ kW} \times 410 \div \text{_____ GPH} = \text{_____ }^{\circ}\text{F}\Delta\text{T}$$

Flow Rate:

$$\text{_____ kW} \times 410 \div \text{_____ }^{\circ}\text{F}\Delta\text{T} = \text{_____ GPH}$$

Electrical

1 PHASE: kW x 1000 ÷ Voltage = Amps 1ϕ

3 PHASE: kW x 1000 ÷ Voltage ÷ 1.73 = Amps 3ϕ

Example

150 kW at 480V 3ϕ

150 x 1000 ÷ 480 ÷ 1.73 = 180 Total Amp Draw

180 ÷ 48 Amps max circuit rating = 3.75

Round up the number of circuits to 4

Note: Each branch circuit is rated at a maximum of 48 Amps and each circuit is typically operated as an independent temperature step.

Metric Conversions

Liters x 0.2641 = Gallons

psi x 6.86 = kPa

Gallons x 3.79 = Liters

kPa x 0.1456 = psi

Gallons x 0.003785 = m3

Lbs x 0.4536 = Kg

m3 x 264.2 = Gallons

Kg x 2.2 = Lbs

1°C ΔT = 1.8°F ΔT

Watts/Sq.Cm. x 6.4 =

°F = (°C x 1.8) + 32

Watts/Sq.In.

°C = (°F - 32) x 0.556

Watts/Sq.In. x 0.155 =

psi x 0.06896 = Bar

Watts/Sq.Cm.

Bar x 14.5 = psi



All information is subject to change without notice. Consult factory for submittal drawings.

Signature SH and H Model Number Designation

MODEL	MODEL NUMBER	UPPER kW*	LOWER kW*	TANK	VOLTAGE / PHASE	OPTIONAL EQUIPMENT
SH = Vertical	80 - 10,000**	0 -1600 kW	5 -1600 kW	SL = Cement lined steel	RS = 208/1 R = 208/3 S = 240/1 T = 240/3 W = 277/1 T3 = 380/3 T7 = 415/3 T5 = 440/3 T4 = 480/3 T6 = 600/3	Write/type optional equipment code in the gray box below in alphabetical order. For multiple options separate codes with a dash (-). (See Optional Equipment Codes on page 10).
				CN = Solid 90/10 copper-nickel		
				SS = Solid stainless steel 316L <i>CN and SS tanks come standard with galvaneal jacket and fiber-glass insulation.</i>		
H = Horizontal*						

*Horizontal model is not available with upper kW and not available with the option of PBA.

**Above 10,000 available, consult sales team

Example: SH350-o-90SLT4-C35

Vertical 350 gallon storage capacity water heater with a 90 kW heating element. Tank is cement lined. Power required is 480 VAC, 3 phase, with optional BACnet communication module with T1000 digital controller.



All information is subject to change without notice. Consult factory for submittal drawings.

Optional Equipment

Optional equipment may impact overall dimensions and weight. Please request submittal drawing from factory

Controller

- C5** Low Water Cutoff
- C15** Non-Fused Disconnect Switch
- C16** Fused Disconnect Switch
- C20** Enable/Disable Relay (Specify Voltage)
- C21** Dry Contact for Remote Alarm Capability (Specify Condition)
- C31** Leak Detection - Includes Sensor Pad and Dry Contact for BMS Notification
- C35** BACnet Communication Module with T1000 Digital Controller
- C59** Integrated PLC Control Package

Electrical

- E2** Indicating Lamps (Specify Color and What it is Indicating)
- E3** Audible Alarm (Specify Fault)
- E8** Built-In Circuit Breaker with Safety Handle
- E12** Specialized Heating Element Construction (Reference Electric Heating Element Option List)

General

- G1** Combination Temperature & Pressure Gauge: 3.5" Dial, 70°F - 250°F, 0 - 200 PSI, Tank Mounted
- G2** Intra-Tank Circulation Pump Package with On/Off Switch To Continuously Circulate Water within the Tank
- G9** Explosion Resistant Construction (Specify Class, Division, Group, and Temperature Class)
- G16** NEMA 4X Rating
- G17** NEMA 4 Rating
- G22** 316L Stainless Steel Temperature and Pressure Relief Valve
- G23** Factory Supplied Thermostatic Mixing Valve to Supply High Volume Tepid Water for Safety Shower Systems. For Details, Please Reference Hubbell Model EMV
- G25** Outdoor Weather Package (304 SS Jacket and 6" Legs, NEMA 4X Electrical Housing (& Mixing Valve Housing on EMV)

Vessel

- V3** 3" Polyurethane Foam Insulation
- V5** Optional 200 PSI Working Pressure. If Other than 200, Use Code -V5-XX and Specify Pressure
- V11** 2" Inlet/Outlet Connections
- V15** Additional 3/4" FNPT Tappings
- V16** Additional 1-1/2" FNPT Tappings
- V17** Additional 3" FNPT Tappings
- V19** Inspection Port 3" NPT Size
- V24** Field Removable 304 SS Jacket
- V25** Field Removable 316L SS Jacket
- V26** Field Removable Galvanneal Jacket
- V27** ASME Section VIII Div. 1 Construction
- V43** Horizontal Shipping Saddles (Required on All Vertical Models with Crated Shipping Dimension Over 96" High)
- PBA** PBA is the Standard model for the Omni Heat Pump Systems. The PBA comes standard with:
 - Six (6) FNPT Openings (2" Under 400-Gallon; 3" 400-Gallon or Over)
 - Three (3) 3/4" FNPT Openings; Two (2) 2" FNPT Openings or One (1) 12" X 16" Manway
 - All Openings Except Manway to be 304SS
 - 3" Polyurethane Foam Insulation, with a minimum of R=21
 - If Swing Tank with Electric Elements, Include Option C35 - T1000 Controller with BACnet Module
 - Tapping Locations to be Consistent with Standardized Designs

Please note: Optional equipment may impact overall dimensions and weight. Please request submittal drawing from factory.

Please contact the Hubbell sales team to discuss your specific needs.

Available Accessories

10-year Warranty: 10-year non pro-rated tank warranty, specify part number "VESSEL WARRANTY"

Accessories Name	Part #