



Semi-Instantaneous Water Heater Steam-to-Water

Provides commercial and institutional buildings with potable hot water

Available in horizontal or vertical orientation

Prepackaged system with factory sized components, making for an easy installation

Outstanding thermal efficiency, high quality ASME coded construction

- Heating coil is available in single and double wall tubing with various material options
- Additional options to meet diverse application needs

Applications

Hospitals, correctional facilities, office buildings, university dormitories, military bases.

A long lasting, trouble-free water heater

The Synergy Steam STX is a fully packaged semi-instantaneous steam fired water heater that heats potable water. It has digital temperature controls, outstanding thermal efficiency, stainless steel ASME pressure vessel, and requires minimal floor space.



SYNERGY STEAM SERIES
STX

Over 100 years of water heating expertise

Hubbell water heaters are the right choice for your commercial and industrial applications. We have water heating solutions for most energy sources with storage capacities from 1–10,000 gallons—all designed, engineered, and manufactured for reliability and longevity coupled with unparalleled support and service.

NOTE: Manufactured in an ISO 9001:2015 facility. BABA & BAA compliance is available upon request.



Meets the requirements of the ASME Boiler and Pressure Vessel Code

Standard Equipment

Shell & Tube Bundle

- ASME Section VIII Division I vessel stamped for 150 psig design working pressure (MAWP).
- National Board registered
- Vertical or horizontal model with solid 316L stainless steel construction and 304L stainless steel fittings
- Steel vertical stand
- SB-75 seamless copper U-tube
- 304 stainless steel tube sheet

Controls

- Electric, Pneumatic and Pilot operated control valve for steam
- 150 psig ASME pressure relief valve
- High limit aquastat
- Safety solenoid valve
- NEMA 4X/IP66 (single point electric connection)
- Control voltage 120v/1ph/60Hz, 10 amps
- Temperature gauge
- 1/25 HP recirculator pump
- Condensate orifice trap and steam strainer
- F&T steam trap
- Thermostatic drip trap

Standard Features

- Close temperature controls with $\pm 4^{\circ}\text{F}$ at heater hot water outlet under normal operating conditions
- Solid rust-free stainless steel construction on the entire domestic water side and standard stainless steel mirror finish jacket
- Compactly sized requiring minimum space for installation, with vertical or horizontal heater choice
- Tube bundle readily accessible without removing shell or foundation for all single wall models; recommended horizontal mounting of double wall due to coil length
- Standard sizes cover hot water output from 5 to 650 GPM simplifying size selection and layout

Optional Equipment

Shell & Tube Bundle

- Horizontal model available with or without rack
- Double wall copper or cupro-nickel (90/10) tubing
- Single wall cupro-nickel (90/10) or 316L stainless steel tubing
- 250 psig shell and tube design working pressure
- 400 psig tube design working pressure
- (for HTW and HPS)
- Heat-treated shell for high-chloride application

Support

- Steel horizontal rack for 1 or 2 Mini-Pack
- Seismic support

Controls

- Electric, pneumatic water valves or pilot operated for steam
- Double safety solenoid dump valve
- Temperature & pressure gauge
- Dual valves setup: 1/3 and 2/3 pneumatic control
- Building automation relays
- T&P steam trap
- Alarm bell with silencer switch

Operating Controls

- Digital panel¹ (standard on electric)
- Remote Setpoint panel¹
- Building Automation panel¹





Control Options

1. Digital

Uses microprocessor based PID loop controller with RTD temperature sensor. The controller includes digital outlet temperature readout on two line/four button user interface, auto tuning, manual output control, high/low deviation alarm, 4-20mA control signal.

2. Electro-Pneumatic

Uses microprocessor based PID loop controller with RTD temperature sensor. The controller includes digital outlet temperature readout on two line/four button user interface, auto tuning, manual output control, high/low deviation alarm, 4-20mA control signal. The 4-20 mA signal is converted to an air control signal using an I/P (Current-to-Pneumatic) positioner.

3. Pilot

A pilot control valve senses fluid temperature with a bulb and capillary tube, then uses that signal to automatically adjust a larger main valve, controlling the flow to maintain a set temperature.

4. Pneumatic

The fluid temperature is sensed using a bulb that is integral to the temperature regulator. The temperature regulator is robust, non-indicating, and modulates the flow to maintain a set temperature.

BMS

Hubbell products come equipped with a digital PID control panel, capable of communicating with Building Management Systems (BMS) over Modbus Serial (RS-485), Modbus TCP/IP (Ethernet) or BACnet/IP (Ethernet). A communications router is available separately if BACnet/MSTP (serial) is required for the installation. The communications protocols allow near complete control over the unit remotely, allowing the operator to view and change an extensive list of available operational parameters.

Remote setpoint

A remote setpoint is a desired target value for a control system that is entered electronically from an external source, rather than directly on the device itself. It allows adjustment of the setpoint using a 4-20mA signal from a different location, enabling automated control in complex systems, multi-zone setups, or master/slave configurations.

Control Method	Standard Control	Digital Control	BMS	Remote Set Point
1. Digital	✓	✓	✓	○
2. Electro-Pneumatic	○	✓	○	○
3. Pilot	○	✗	✗	✗
4. Pneumatic	○	✗	✗	✗

✓ Available ○ Optional ✗ Not Available

The STX Temperature Control System

The temperature control system keeps the heated water within four degrees of the selected temperature. This is accomplished by placing the temperature control element directly in the constant flow path of the water leaving the heating surface making “anticipator” devices unnecessary. After the water passes over the control element it enters a tempering chamber between the heating surface and the water outlet.

Another essential part of the temperature control system is the integral circulator. This small pump (1/25 HP):

- Constantly recirculates a portion of the heated water to the cold water inlet making the total volume of the heater a tempering chamber.
- Eliminates any overheated water pockets caused by control valve lag when hot water demand is suddenly reduced.
- Can be used to provide recirculation of the water from the fixtures through a tee fitting that is provided with the package.
- When the hot water return system requires greater recirculation the integral pump size can be pre-selected to provide the duty.

Robust Construction

The STX features total rust free construction with austenitic stainless steel and copper for all domestic water contact surfaces, providing high quality, low maintenance and an extremely cost-effective domestic water heating package. Non-metallic PTFE baffles are used to prevent tube damage.

The **vertical STX** semi-instantaneous heater saves floor space, is simple to install and very easy to service and maintain. The vertical unit also provides complete drainage of condensate. Universal mounting brackets allow the STX to be mounted in the horizontal position.



Advantages of the Synergy Steam STX

Condensing Design – Sub-Cooled Condensate

Sub-cooling condensate maximizes the heat transfer efficiency of a heat exchanger. By using a condensing design, the STX condenses steam in the tubes and cools condensate well below its flash temperature. This is achieved by simultaneously flowing entering cold water across the tubes carrying exiting condensate while using an orifice to restrict condensate drainage. Depending on the load, exiting condensate temperatures are typically 10-15 degrees higher than the exiting domestic hot water temperature.

Several benefits are realized from sub-cooling condensate:

- Sub-cooling can increase efficiency by as much as 25% which results in less steam required to heat the same GPM.
- Heat typically lost to flash heats the domestic water instead of being lost in the condensate receiver or flash tank
- Mechanical spaces are much cooler.
- Pumping cooler condensate greatly extends the life of pumps.

Heavy Wall Heat Exchanger Tubes

The Hubbell STX uses heavy duty, 0.049" wall copper heat exchanger tubes... twice the wall thickness as tubes used by other leading water heater manufacturers. Thicker tube walls increase the longevity of the heat exchanger and provide improved efficiency. Thin wall tube bundles cost less, but can result in premature failure and high replacement cost. 0.049" tubing can last up to 25 to 30 years. 0.049" wall seamless SB75 copper tubing is standard on Hubbell STX.

Double Solenoid High Temperature Safety Systems

The double solenoid system adds safety and guards against scalding. At a pre-determined high temperature setpoint, the system provides annunciation to the EMS system before a dangerous condition develops or the domestic hot water loop cools down. The system discharges at a lower temperature before the relief valve discharges (at 210°F). This safety system is optional on Hubbell STX and storage water heater packages.

Extended Non-Prorated Warranty

The Hubbell STX offers a factory extended, 10-year (or 10/20-year), non-prorated warranty that includes all wetted components (shell, heat exchanger tube sheet, etc).



Steam-To-Water STX

ASME Code, Section VIII, Division 1 constructed pressure vessel, National Board registered. All stainless steel construction on the water side, pressure vessel quality carbon steel on the steam side.

1.5" thick rigid fiberglass insulation with a 24 gauge annealed stainless steel jacket. Minimizes standby heat loss, is durable and looks great.

NEMA 4X, UL listed control panel with a user friendly control interface, off/on switch, power indicator, and over temperature alarms. All internal components are sized accordingly.

Electric steam control valve, fail closed in the event of power loss or over temperature. Available in pneumatic, electro-pneumatic, and pilot

HOT STEAM INLET

Steam inlet strainer

Steam pressure gauge with isolation valve and siphon.

CONDENSATE OUTLET

Single wall tube bundles can be removed from the bottom without removing the shell or steel base. Double wall tube bundles require shell removal.

Structural steel base requires minimum floor space.

HOT WATER OUTLET

Secondary high temperature set point opens a water solenoid valve, dumping hot water down a drain.

Water temperature gauge.

ASME temperature and pressure relief valve.

Integral stainless steel circulator, acts as an anticipator and eliminates stratification. Provided with isolation valves for ease of maintenance.

Water drain valve

COLD WATER INLET

Single or double wall tube bundle, available in copper, 90/10 copper-nickel, 316/L Stainless steel and titanium.

Teflon baffles extend the life of the tube bundle.

Steam vacuum breaker

Float and thermostatic (F&T) steam traps combine a ball float and thermostatic element to continuously discharge condensate and vent air, making them ideal for process equipment with high, variable loads.

THERMOSTATIC DRIP DRAP TO REMOVE EXCESS CONDENSATE AND PROTECT THE CONTROL VALVE

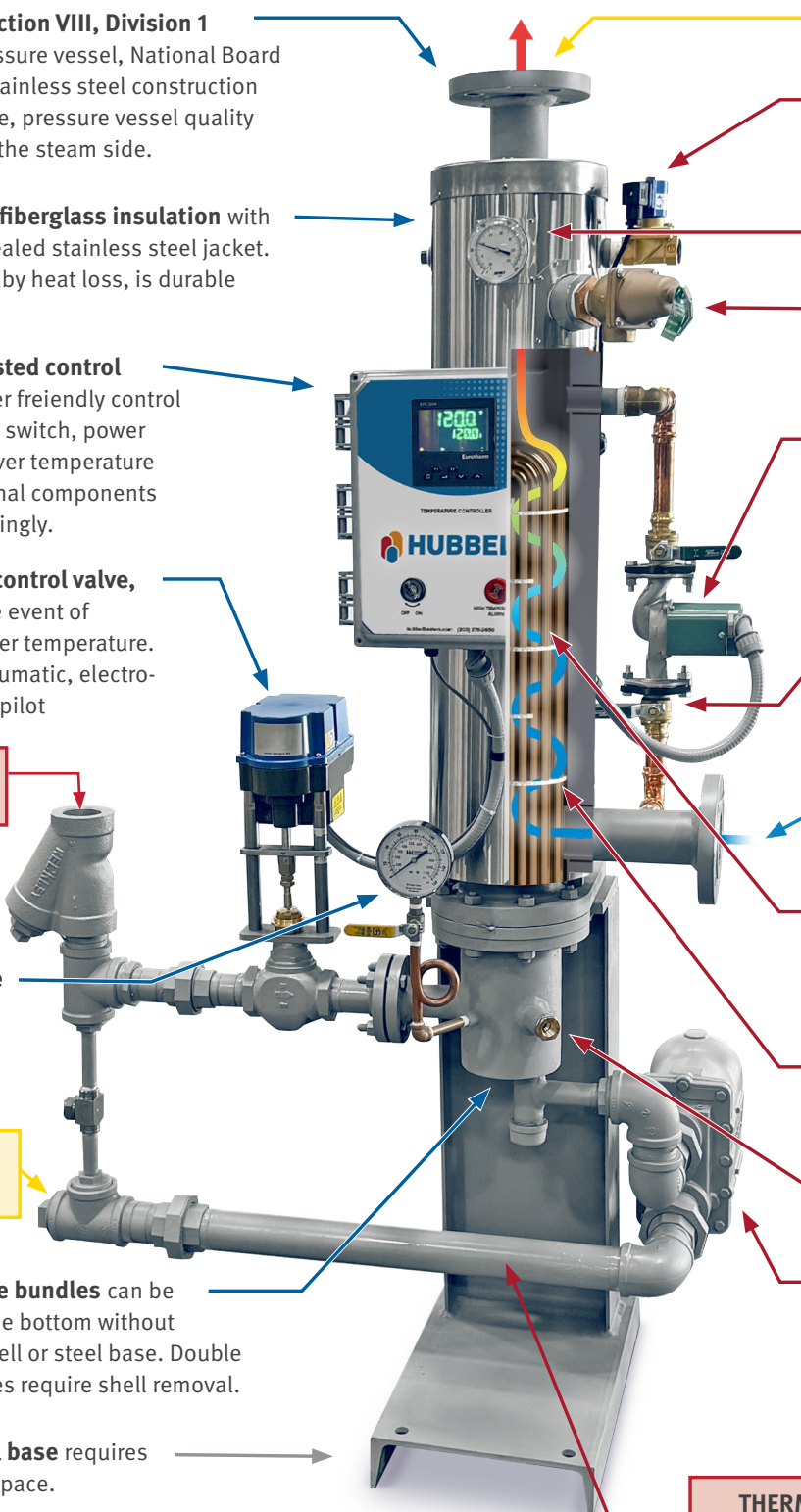



Construction

All semi-instantaneous water heaters must have non-ferrous shell construction to accommodate rust-free domestic, potable water. The STX shell construction is unlined 316L stainless steel. Other leading manufacturers use a carbon steel shell with a thin copper lining on the water side. Liners are problematic because they can separate or split. Such failure exposes domestic water to carbon steel and can result in rusty, discolored, and contaminated water. Conversely, unlined shells are trouble-free. The Hubbell STX unlined 316L stainless steel shell construction has no equal in the industry and is far superior to a copper-lined, carbon steel shell.

Design Versatility

The Hubbell STX is ideal for small mechanical spaces. The STX unit is available in a variety of configurations including vertical and horizontal, and single or double wall tubes. Horizontal units are preferred where headroom is a constraint. In the horizontal configuration, dual units can be stacked to minimize required floor space and reduce installation cost. If the condensate line is too high, the horizontal unit will enable gravity discharge of condensate and eliminate the need for a condensate receiver and pumpset. The vertical configuration has an extremely small footprint and does not require significant headroom clearance for servicing.

Temperature Control

There are two basic types of temperature controls used on semi-instantaneous water heaters: active systems (with a pump) and passive systems (without a pump). Both designs are characterized as 'anticipatory feed-forward' type temperature control systems and will control +/- 4°F at 'normal load variations'. The STX uses an active system which uses a 1/25 HP, all bronze circulator to maintain constant flow over the temperature sensing element. This ensures fast response and tight temperature control at all load profiles. Passive systems rely on the differential pressure of the water flowing over the heat exchange surface and can save the cost of operating the small circulator. However, they cannot control temperature as well as pumped systems can at low flow conditions. With a pumped system, temperature control is very tight at all load profiles. The STX temperature control system is simple, fast and accurate.

Serviceability

Servicing the STX is fast, easy, and inexpensive. Parts are reasonably priced and readily available. The O&M manual outlines respective part numbers for each accessory manufacturer. All of the STX accessories are readily available from local plumbing supply houses. In addition, the STX is designed to be completely serviced in place without an overhead clearance requirement or the need to lay the unit horizontally. On single-wall vertical units, enough clearance exists under the stand to completely remove the heat exchanger.

Health Issues (i.e. Legionella)

The three conditions that must be present to promote the growth of the Legionella organism are:

- Host (usually in the form of scale)
- Low velocity
- Water temperatures between 68°F - 122°F.

The Hubbell STX is designed to keep the shell side domestic water in constant circulation via the 1/25 HP circulator. This keeps the entire volume of water in the shell at set-point temperature and eliminates temperature stratification common in the designs of our leading competitors. Most importantly, the STX design eliminates the proliferation of Legionella bacterium by maintaining safe water temperatures and higher water velocities and minimizing scale formation.

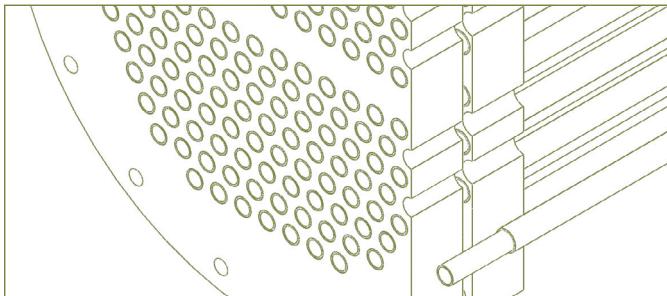

Conclusion

The **Hubbell Synergy Steam STX** water heater has been tested and used for more than two decades in demanding, high volume water heating applications. It is a proven design that is simple, efficient, and trouble-free and offers building owners and maintenance personnel numerous end-user features and benefits. Specifying the Hubbell STX water heater combines the highest levels of quality, efficiency, and safety with a long lasting, cost-effective design that is inexpensive to operate and easy to service.



Single-Wall Steam-to-Water Dimensions

Vertical

Model	Height A	Width B	Depth C	SHIPPING WEIGHT (LBS)
STXVSW-4S	82-15/16	33-1/4	21	350
STXVSW-5S	69-11/16	35-3/4	21	400
STXVSW-6S	85-13/16	36-1/2	21	500
STXVSW-8S	75-5/16	38-3/4	21	600
STXVSW-8LS	88-5/16	38-3/4	21	650
STXVSW-10S	79-1/4	46-3/4	27	900
STXVSW-10LS	92-1/4	46-3/4	27	950
STXVSW-12S	83-1/4	49-3/8	27	1,125
STXVSW-12LS	107-1/4	49-3/8	27	1,175
STXVSW-14S	98-1/4	52-5/8	30	1,700
STXVSW-14LS	128-1/2	52-5/8	30	1,800
STXVSW-16S	121-3/4	56-7/16	30	2,200
STXVSW-16LS	135-3/4	56-7/16	30	2,350

All dimensions in inches. Dimensions are subject to change.

See Page 14 for complete model number schema.

¹Connections 4" IPS and above 150# ANSI FLG

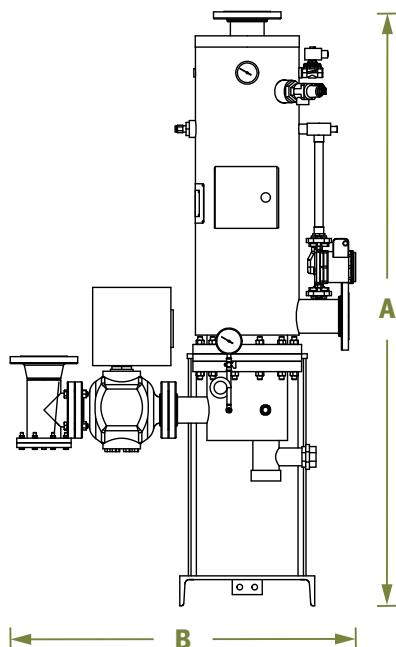
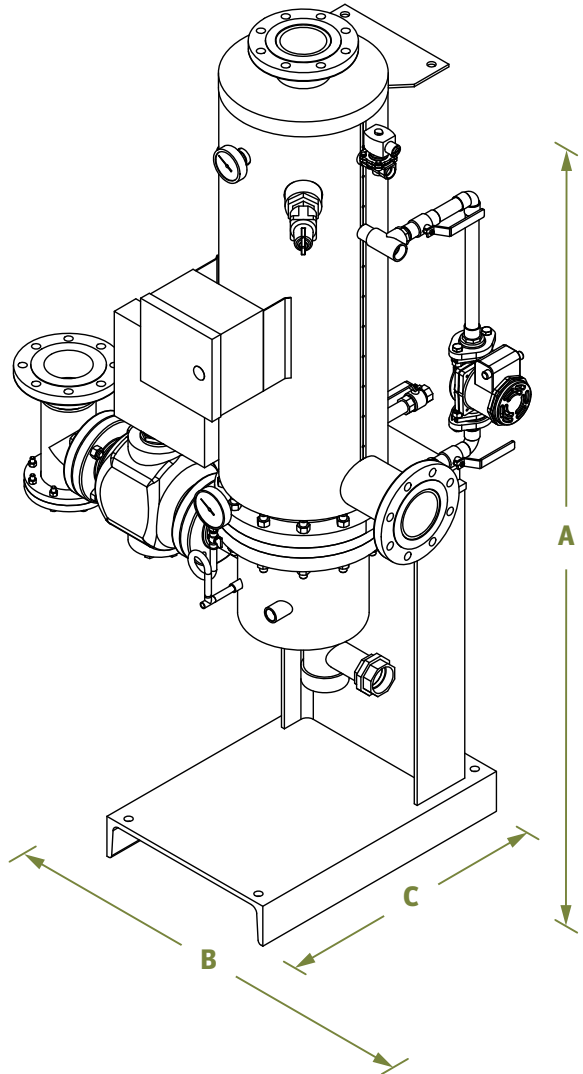

Single-Wall Steam-to-Water Dimensions

Horizontal

Model	Height A	Width B	Depth C	SHIPPING WEIGHT (LBS)
STXHSW-4S	31-3/4	33-1/4	56	300
STXHSW-5S	33-7/8	35-3/4	49	350
STXHSW-6S	36-1/4	36-1/2	57-3/8	450
STXHSW-8S	41-3/16	38-3/4	53-7/8	550
STXHSW-8LS	41-3/16	38-3/4	59-7/8	600
STXHSW-10S	45-1/16	46-3/4	57	850
STXHSW-10LS	45-1/16	46-3/4	63	900
STXHSW-12S	49-3/4	49-3/8	63-15/16	1,075
STXHSW-12LS	49-3/4	49-3/8	75-15/16	1,125
STXHSW-14S	49-3/4	52-5/8	73-1/16	1,650
STXHSW-14LS	49-3/4	52-5/8	88-5/16	1,750
STXHSW-16S	51-1/4	56-7/16	88-1/16	2,150
STXHSW-16LS	51-1/4	56-7/16	102-1/16	2,300

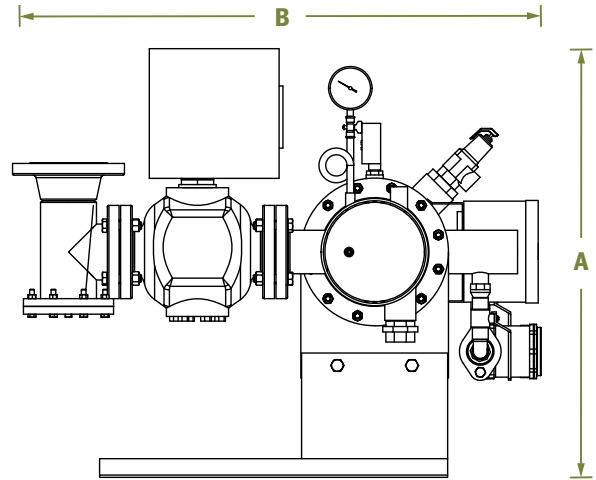

All dimensions in inches. Dimensions are subject to change.

See Page 14 for complete model number schema.

¹Connections 4" IPS and above 150# ANSI FLG

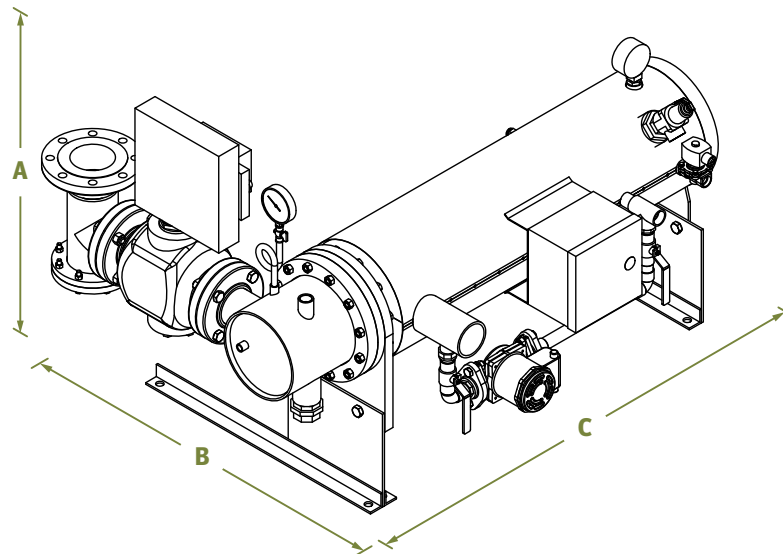

Double-Wall Steam-to-Water Dimensions

Vertical

Model	Height A	Width B	Depth C	SHIPPING WEIGHT (LBS)
STXVDW-5S	93-7/8	35-3/4	21	400
STXVDW-6S	97-3/8	36-1/2	21	500
STXVDW-8S	98-5/8	38-3/4	21	600
STXVDW-10S	105-1/4	46-3/4	27	1,000
STXVDW-12S	110	49-3/8	27	1,300
STXVDW-14S	121	52-5/8	30	1,900
STXVDW-16S	127	56-7/16	30	2,450

All dimensions in inches. Dimensions are subject to change.
See Page 14 for complete model number schema.

¹ Connections 4" IPS and above 150# ANSI FLG

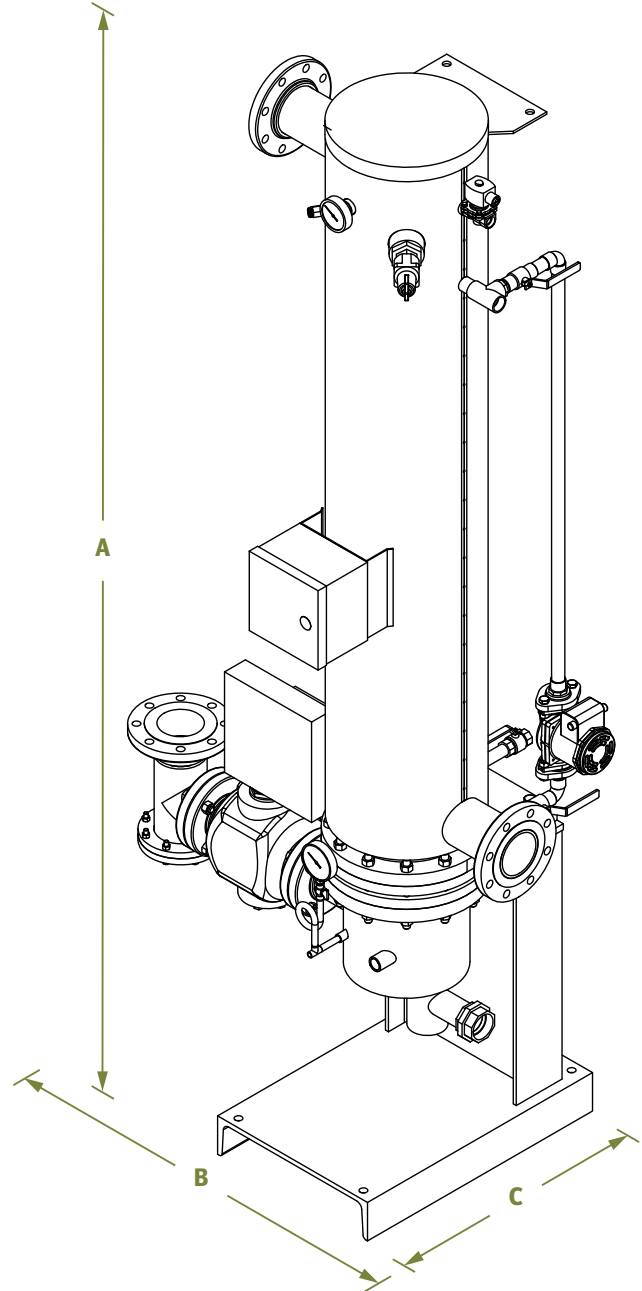
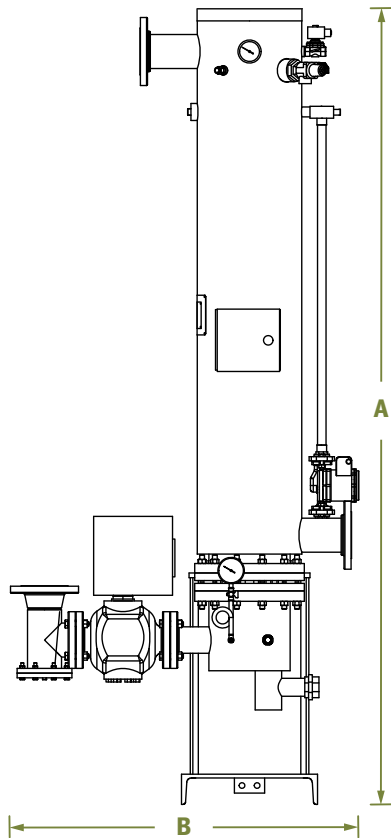

Double-Wall Steam-to-Water Dimensions

Horizontal

Model	Height A	Width B	Depth C	SHIPPING WEIGHT (LBS)
STXHWD-5S	33-7/8	37-7/8	80-3/16	435
STXHWD-6S	35	60-1/8	81-5/16	535
STXHWD-8S	39-1/16	57-1/8	83-9/16	635
STXHWD-10S	43-1/4	54-1/2	87-1/8	950
STXHWD-12S	48-1/8	46-1/2	94-7/16	1,200
STXHWD-14S	48-7/8	38-3/8	104-1/16	1,750
STXHWD-16S	49-5/8	63-1/8	110-15/16	2,250

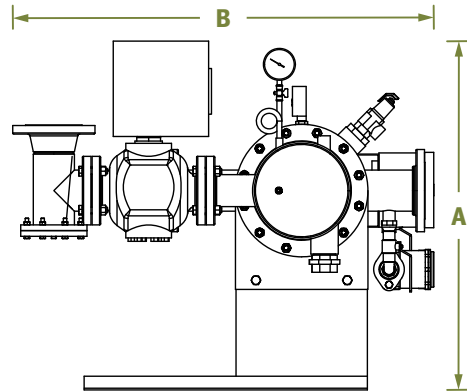

All dimensions in inches. Dimensions are subject to change.
See Page 14 for complete model number schema.

¹ Connections 4" IPS and above 150# ANSI FLG

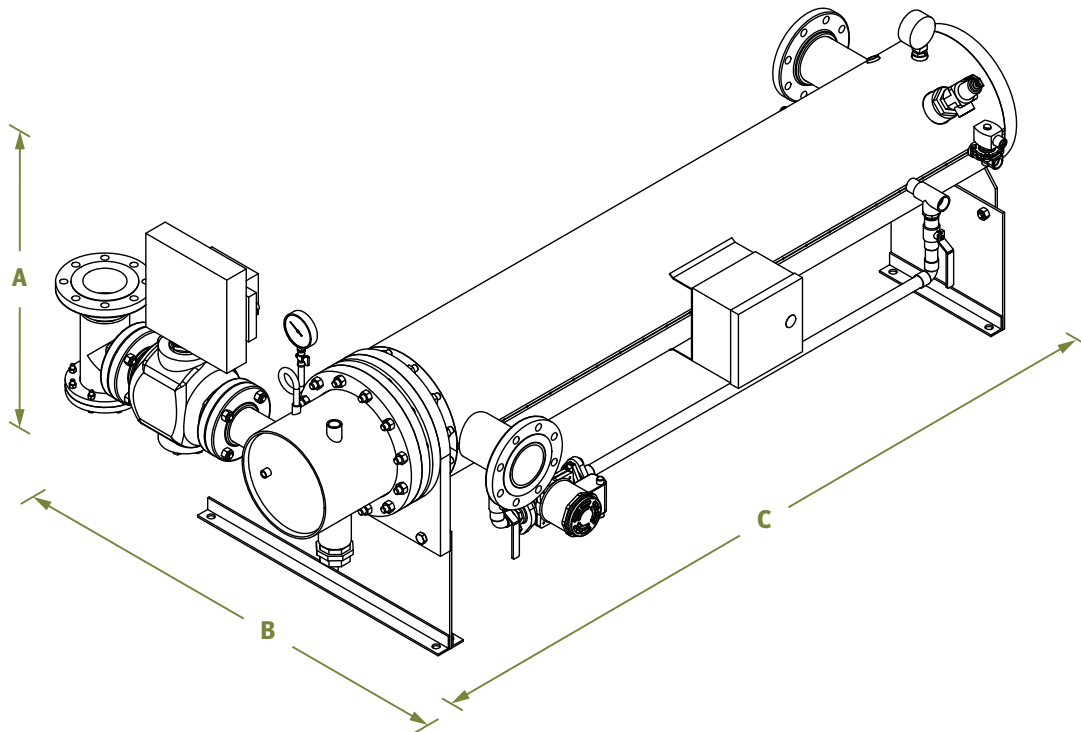

STX Coil Selection Guide

Single Wall

Temperature Rise 40° to 120° F

STEAM PRESSURE TO CONTROL VALVE						
GPM	5 psi	10 psi	15 psi	30 psi	50 psi	75 psi*
10	4S	4S	4S	4S	4S	4S
20	4S	4S	4S	4S	4S	4S
30	4S	4S	4S	4S	4S	4S
40	6S	5S	5S	5S	5S	5S
50	6S	5S	5S	5S	5S	5S
60	8S	6S	5S	5S	5S	5S
80	8S	6S	6S	5S	5S	5S
100	8S	8S	8S	8S	8S	5S

Single Wall

Temperature Rise 40° to 140° F

STEAM PRESSURE TO CONTROL VALVE						
GPM	5 psi	10 psi	15 psi	30 psi	50 psi	75 psi*
10	4S	4S	4S	4S	4S	4S
20	4S	4S	4S	4S	4S	4S
30	4S	4S	4S	4S	4S	4S
40	6S	5S	5S	5S	5S	4S
50	8S	6S	5S	5S	5S	5S
60	8S	6S	6S	5S	5S	5S
80	8S	8S	6S	5S	5S	5S
100	10S	8S	8S	8S	8S	6S

Single Wall

Temperature Rise 40° to 160° F

STEAM PRESSURE TO CONTROL VALVE						
GPM	5 psi	10 psi	15 psi	30 psi	50 psi	75 psi*
10	4S	4S	4S	4S	4S	4S
20	4S	4S	4S	4S	4S	4S
30	6S	5S	4S	4S	4S	4S
40	8S	6S	6S	5S	5S	4S
50	8S	6S	6S	5S	5S	5S
60	8S	8S	6S	5S	5S	5S
80	10S	10S	8S	6S	5S	6S
100	10S	10S	10S	8S	8S	6S

Single Wall
Temperature Rise 40° to 180° F

STEAM PRESSURE TO CONTROL VALVE						
GPM	5 psi	10 psi	15 psi	30 psi	50 psi	75 psi*
10	4S	4S	4S	4S	4S	4S
20	5S	4S	4S	4S	4S	4S
30	6S	5S	5S	4S	4S	4S
40	8S	6S	6S	5S	5S	5S
50	8S	8S	6S	5S	5S	5S
60	8S	8S	8S	5S	5S	5S
80	10S	8S	8S	6S	6S	6S
100	10S	10S	10S	8S	8S	6S

Double Wall
Temperature Rise 40° to 120° F

STEAM PRESSURE TO CONTROL VALVE						
GPM	5 psi	10 psi	15 psi	30 psi	50 psi	75 psi*
10	5D	5D	5D	5D	5D	5D
20	5D	5D	5D	5D	5D	5D
30	5D	5D	5D	5D	5D	5D
40	6D	5D	5D	5D	5D	5D
50	6D	6D	6D	6D	6D	5D
60	8D	6D	6D	6D	6D	6D
80	8D	6D	6D	6D	6D	6D
100	8D	8D	8D	8D	8D	6D

Double Wall
Temperature Rise 40° to 140° F

STEAM PRESSURE TO CONTROL VALVE						
GPM	5 psi	10 psi	15 psi	30 psi	50 psi	75 psi*
10	5D	5D	5D	5D	5D	5D
20	5D	5D	5D	5D	5D	5D
30	6D	6D	5D	5D	5D	5D
40	6D	5D	5D	5D	5D	5D
50	8D	6D	6D	6D	6D	5D
60	8D	6D	6D	6D	6D	6D
80	8D	8D	6D	6D	6D	6D
100	10D	10D	10D	8D	8D	8D

Double Wall
Temperature Rise 40° to 160° F

STEAM PRESSURE TO CONTROL VALVE						
GPM	5 psi	10 psi	15 psi	30 psi	50 psi	75 psi*
10	5D	5D	5D	5D	5D	5D
20	5D	5D	5D	5D	5D	5D
30	6D	5D	5D	5D	5D	5D
40	8D	6D	5D	5D	5D	5D
50	8D	6D	6D	6D	6D	6D
60	8D	8D	6D	6D	6D	6D
80	8D	8D	8D	8D	6D	8D
100	10D	10D	10D	8D	8D	8D

Double Wall
Temperature Rise 40° to 180° F

STEAM PRESSURE TO CONTROL VALVE						
GPM	5 psi	10 psi	15 psi	30 psi	50 psi	75 psi*
10	5D	5D	5D	5D	5D	5D
20	5D	5D	5D	5D	5D	5D
30	6D	6D	5D	5D	5D	5D
40	8D	6D	6D	5D	5D	6D
50	8D	8D	8D	6D	6D	6D
60	8D	8D	8D	6D	6D	8D
80	10D	8D	8D	8D	8D	8D
100	10D	10D	8D	8D	8D	8D

Synergy Steam STX Number Designation

MODEL	VESSEL TYPE	COIL SIZE (DIAMETER INCHES)	COIL TYPE	COIL MATERIAL	VALVE TYPE	VALVE SIZE (INCHES)	OPTIONAL EQUIPMENT
STX = Vertical	SS = Stainless	4	S = Single wall	C = Copper	P = Pilot	050 = ½	
STXH =	Steel	5	D = Double wall	CN = Copper	A = Pneumatic	075 = ¾	
Horizontal	CN = Copper	6		Nickel	E = Electric	100 = 1	
	Nickel	8		S = Stainless		125 = 1-¼	
		8L		Steel (Single		150 = 1-½	
		10		wall only)		175 = 1-¾	
		10L				200 = 2	
		12				250 = 2-½	
		14				300 = 3	
		16				400 = 4	

Example: **STXSS-4S-CE125-C36**

A vertically installed semi-instantaneous steam fired water heater with a 316L stainless steel pressure vessel, 4-inch single wall copper coil, electric 1-1/4 valve and an optional BACnet Gateway module.

Optional Equipment *Optional equipment must be called out in the written specifications, use the codes below.*

Controls

C20 Enable/Disable Relay (Specify Voltage)
C21 Dry Contact for Remote Alarm Capability
 (Specify Condition)

C36 BACnet Gateway Module
C37 Lontalk Gateway Module

Please Note: *Optional equipment may impact overall dimensions and weight. Please request submittal drawing from factory.*

