



OPERATING AND MAINTENANCE MANUAL

Synergy ST and STH

10/23/23



-IMPORTANT-

Always reference the full model number and serial number when calling the factory.

HUBBELL ELECTRIC HEATER COMPANY
45 SEYMOUR STREET
STRATFORD, CT 06615

PHONE: (203) 378-2659
FAX: (203) 378-3593
Hubbellheaters.com

Table of Contents

OUTLINE DIMENSIONS.....	4
OVERALL DIMENSIONS.....	5
NOMENCLATURE FOR PARTS.....	6
NOMENCLATURE FOR ACCESSORY PARTS.....	7
SECTION I - GENERAL DESCRIPTION AND CONSTRUCTION.....	8
GENERAL DESCRIPTION.....	8
CONSTRUCTION.....	8
TANK.....	8
TANK CONNECTIONS.....	8
OUTER SHELL, INSULATION, AND SUPPORTS.....	8
STEAM HEATING COIL.....	9
STEAM OPERATING CONTROLS.....	9
TRAPS.....	9
STEAM CONTROL VALVES.....	9
OPTIONS.....	10
SECTION II – INSTALLATION.....	11
WATER HEATER PLACEMENT.....	11
PIPING INSTALLATION.....	11
HOOK-UP OF AIR AND WATER OPERATED CONTROLS.....	12
ELECTRICAL INSTALLATION.....	13
FILLING THE HEATER.....	13
STARTUP.....	13
SHUTDOWN.....	13
SECTION III – SCHEDULED MAINTENANCE AND SERVICING.....	14
QUARTERLY INSPECTION.....	14
ANNUAL INSPECTION.....	14
GENERAL CONFIGURATION OF STANDARD U-TUBE HEATING ELEMENTS.....	18
SINGLE SAFETY SOLENOID SYSTEM.....	19
DOUBLE SAFETY SOLENOID SYSTEM.....	20
SECTION IV – ADJUSTMENT OF TEMPERATURE REGULATORS.....	21
ADJUSTMENT OF 2-WAY AIR OR WATER OPERATED VALVES.....	21
ADJUSTMENT OF 3-WAY AIR OR WATER OPERATED VALVES.....	21
ADJUSTMENT OF PILOT OPERATED VALVES.....	22

SECTION V – TROUBLESHOOTING 23

SECTION VI – MISCELLANEOUS CHARTS AND FORMULAS 24

TORQUE VALUES 24

METRIC CONVERSIONS 25

WARNING / CAUTION

1. Tank is to be completely filled with water and all air is to be vented before energizing.
2. Due to the rigors of transportation, all connections should be checked for tightness before the heater is placed in operation.
3. Safety relief valve must be installed in tapping provided.
4. KEEP AWAY FROM LIVE ELECTRICAL CIRCUITS. Do not perform any maintenance, make any adjustments, or replace any components inside the control panel with the high voltage power supply turned on. Under certain circumstances, dangerous potentials may exist even when the power supply is off. To avoid casualties, always turn the power supply safety switch to off, turn the charge or ground the circuit before performing any maintenance or adjustment procedure.
5. Generalized instructions and procedures cannot anticipate all situations. For this reason, only qualified installers should perform the installation. A qualified installer is a person who has licensed training and a working knowledge of the applicable codes, regulations, tools, equipment, and methods necessary for safe installation of a steam fired water heater. If questions regarding installation arise, check with your local plumbing and electrical inspectors for proper procedures and codes. If you cannot obtain the required information, contact the company.

OUTLINE DIMENSIONS

**OUTLINE DIMENSIONS
MODEL ST (VERTICAL)**

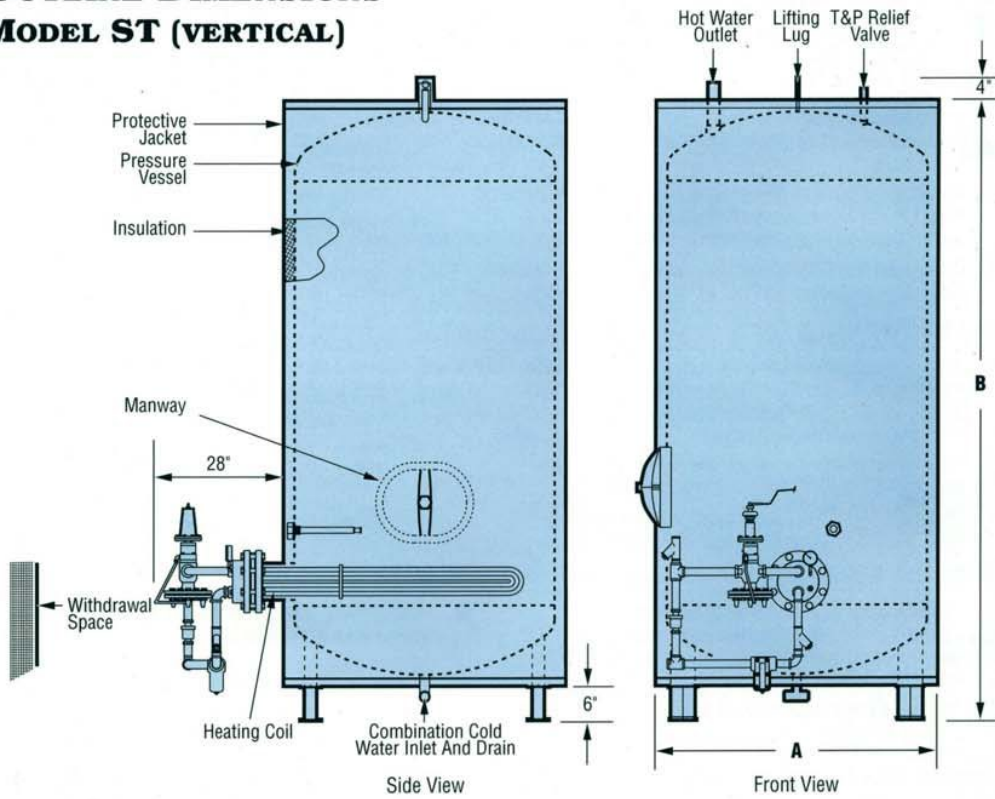

MODEL STH (HORIZONTAL)

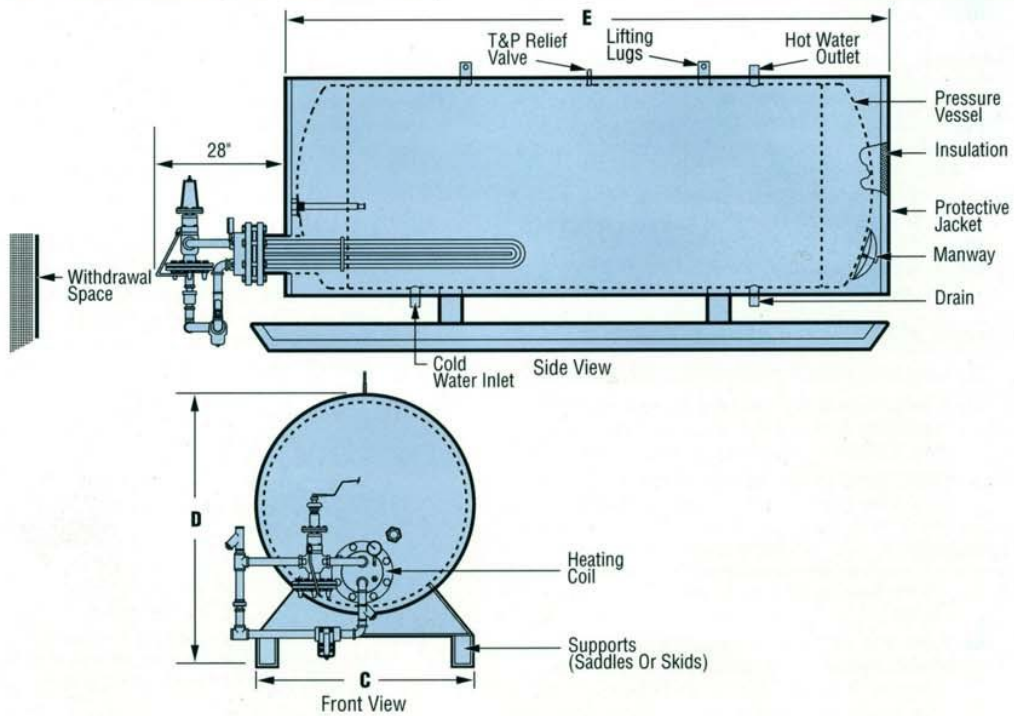

OVERALL DIMENSIONS

OVERALL DIMENSIONS, MODELS ST AND STH								
Storage Capacity (Gallons)	Overall Dimensions (Inches)					Storage Tank Diameter x Length	Inlet Outlet Sizing (NPT)	Approx. Shipping Weight (Lbs.)
	Vertical		Horizontal					
	Diameter "A"	Height "B"	Width "C"	Height "D"	Length "E"			
80	28	56	28	34	50	24 x 46	1.5	1000
120	28	75	28	34	69	24 x 65	1.5	1150
150	34	65	34	40	59	30 x 55	1.5	1300
175	34	73	34	40	67	30 x 63	1.5	1500
200	34	82	34	40	76	30 x 72	1.5	1700
225	34	89	34	40	83	30 x 79	1.5	1750
250	40	74	40	46	68	36 x 64	1.5	1850
275	40	80	40	46	74	36 x 70	1.5	2000
300	40	88	40	46	82	36 x 78	1.5	2180
325	40	92	40	46	86	36 x 82	1.5	2300
350	40	94	40	46	88	36 x 84	1.5	2500
375	46	81	46	52	75	42 x 71	1.5	2600
400	46	85	46	52	79	42 x 75	1.5	2700
425	46	88	46	52	82	42 x 78	1.5	2900
450	46	93	46	52	87	42 x 83	1.5	3000
475	52	79	52	58	73	48 x 69	2	3100
500	52	82	52	58	76	48 x 72	2	3225
525	52	85	52	58	79	48 x 75	2	3350
550	52	89	52	58	83	48 x 79	2	3400
575	52	93	52	58	87	48 x 83	2	3500
600	52	95	52	58	89	48 x 85	2	3650
700	52	107	52	58	101	48 x 97	2	4000
800	52	119	52	58	113	48 x 109	2	4300
900	52	132	52	58	126	48 x 122	2	4800
1000	52	145	52	58	139	48 x 135	2	5200
1250	58	149	58	64	143	54 x 139	2	5600
1500	58	174	58	64	168	54 x 164	2	6000
1750	64	168	64	70	162	60 x 158	3	7400
2000	64	185	64	70	179	60 x 175	3	8100
2500	76	169	76	82	163	72 x 159	3	8200
3000	76	197	76	82	191	72 x 187	3	8300
3500	88	174	88	94	168	84 x 164	6 FLG.	8900
4000	88	195	88	94	189	84 x 185	6 FLG.	9800
4500	N/A	N/A	94	100	178	90 x 174	6 FLG.	10700
5000	N/A	N/A	94	100	100	90 x 196	6 FLG.	11600

NOMENCLATURE FOR PARTS

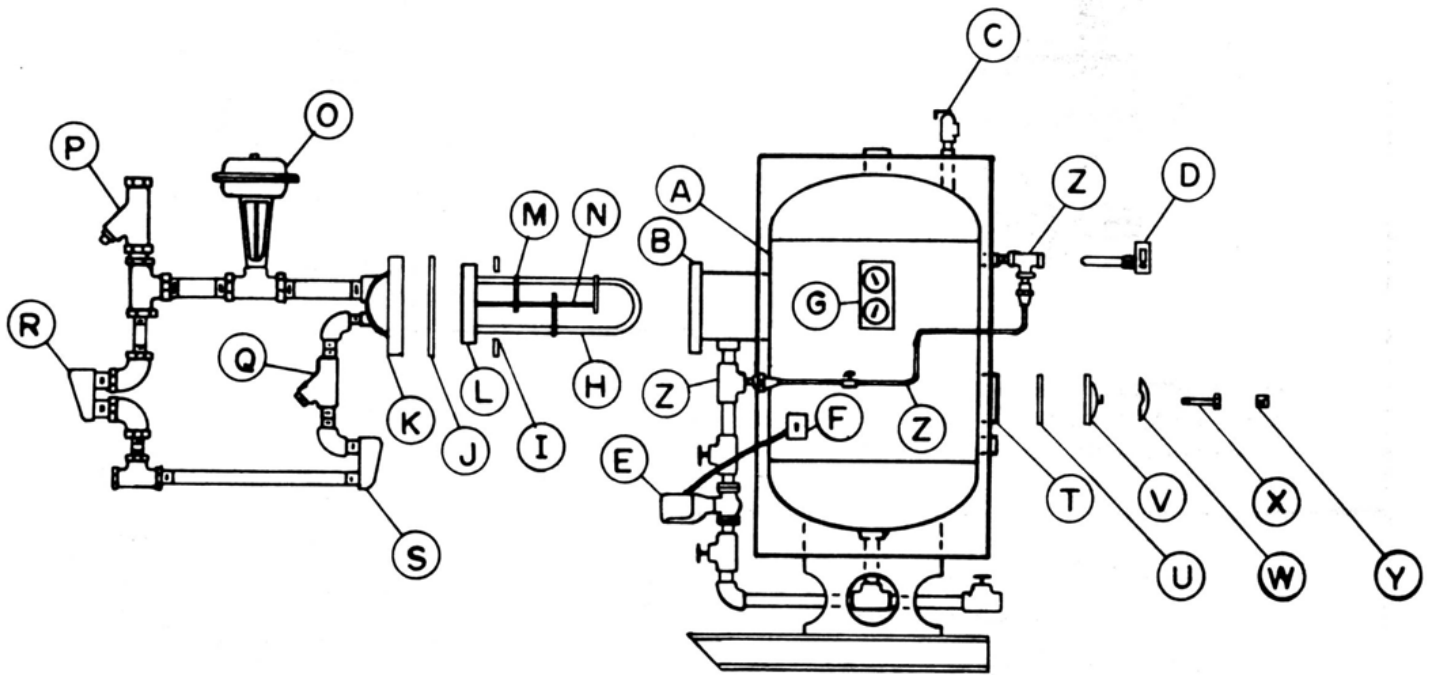

- | | | |
|-----------------------|-------------------------|------------------|
| A Tank Shell | J Tube Side Gasket | S Main Trap |
| B Element Neck | K Element Head | T Manhole Ring |
| C Relief Valve | L Tube Sheet | U Manhole Gasket |
| D Accritem | M Baffle | V Manhole Cover |
| E Integral Circulator | N Tie Rod | W Manhole Crab |
| F Motor Starter | O Temperature Regulator | X Manhole Bolt |
| G Gage Console | P Main Strainer | Y Manhole Nut |
| H Heating Element | Q Condensate Strainer | Z Demand Sensor |
| I Shell Side Gasket | R Drip Trap | |

NOMENCLATURE FOR ACCESSORY PARTS

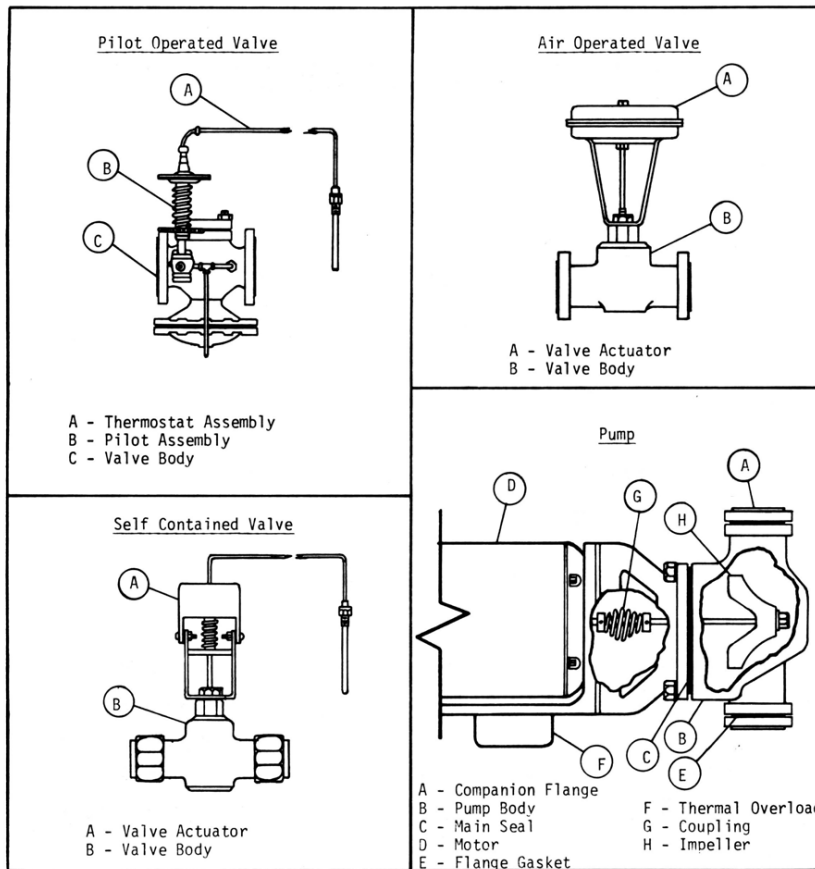

STEAM COMPONENT GENERAL CONFIGURATION

The steam control valve maintains accurate water temperature in a steam fired water heater by regulating the flow of steam through the heating coil.

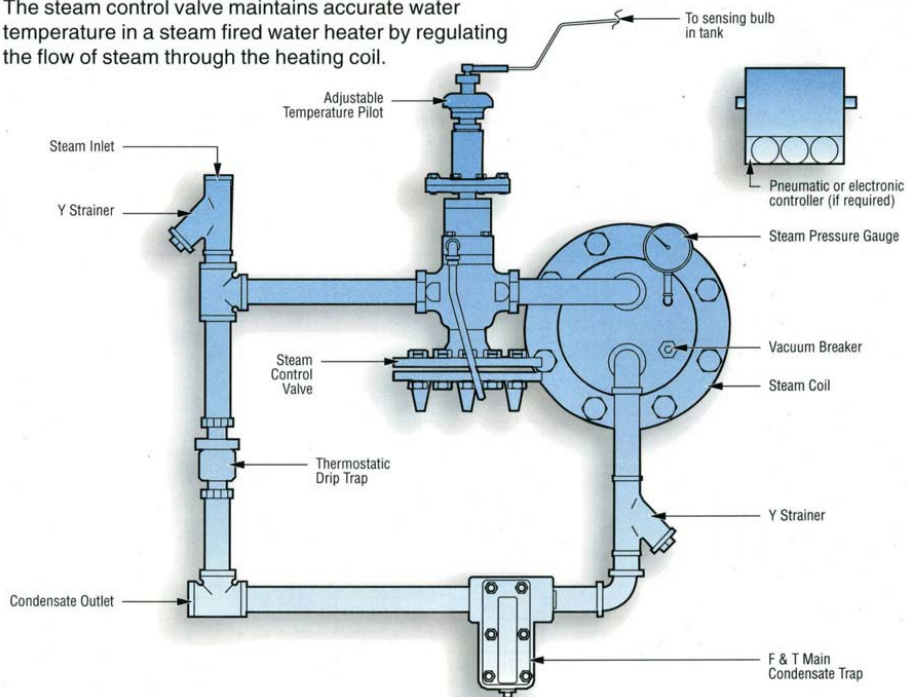

SECTION I - GENERAL DESCRIPTION AND CONSTRUCTION

GENERAL DESCRIPTION

This book describes a packaged steam powered water heater that is a stationary, self-contained unit. The complete assembly on a standard unit consists of the storage tank, immersion heating coil, steam regulator, steam drip trap, condensate trap, steam strainer, condensate strainer, vacuum breaker, and an ASME rated combination temperature and pressure safety relief valve. Optional equipment may be supplied with your unit. Please consult the product drawing for details specific to your assembly. The unit is factory assembled, insulated, jacketed, primed, painted, piped, tested, and ready for service connections.

CONSTRUCTION

TANK

Standard Tank Construction:

The standard storage tank is constructed of all welded carbon steel, designed, and built in accordance with ASME Section VIII and stamped, certified, and registered with the National Board of Boiler and Pressure Vessel Inspectors. It is internally lined with specially formulated HydraStone cement to a 5/8-inch minimum thickness for superior protection and tank longevity.

Optional Tank Linings:

1. Phenolic – An epoxy coating applied in two coats to a total thickness of 10-12 mils. Typically used in process applications using low conductivity deionized (DI), distilled, or food grade water.
2. Copper – A 3lb./sq. ft. copper sheet approximately 0.0646-inches thick covers all interior surfaces. All copper sheet seams are factory tested to ensure long lasting protection of the steel vessel.
3. Flame-Spray Copper – Molten copper is sprayed on the interior surfaces to a thickness of 5-6 mils. The copper bonds to the steel, and an additional overcoat of Phenolic lining is applied on the copper to seal all pores.
4. Galvanizing – The steel pressure vessel is pickled and hot dipped in molten zinc to create a barrier which internally and externally protects the steel vessel for cold and hot water storage.

Optional Non-Ferrous Tank Materials:

1. Copper-Silicon – A copper-silicon alloy offers tremendous tank longevity due to its ability to withstand the cycling effects induced from changes in water temperature and pressure. This material is suitable for storage of hot potable water in a variety of commercial and industrial applications.
2. 90/10 Copper-Nickel – A 90% copper and 10% nickel alloy similar to copper-silicon, but with added strength and corrosion resistance. Typically used in applications with corrosive environments (salt water) or critical applications.
3. Stainless Steel – Stainless steel (Type 304, 316, or 316L) is well suited for high purity applications requiring a corrosion resistant tank with minimal leaching of impurities into the water. Well suited for process, RO, and DI water systems in the pharmaceutical, food, and electronic industries.

TANK CONNECTIONS

The heater is supplied with separate cold water and hot water connections. A connection is provided for mounting a combination safety temperature and pressure relief valve. An overflow line should be utilized from the relief valve outlet to a floor drain. See the drawing for locations and sizes.

OUTER SHELL, INSULATION, AND SUPPORTS

The tank is encapsulated in 2-inches of high-density fiberglass insulation. The protective shell is constructed of galvanized steel and is coated with a durable silver hammertone finish. The entire vessel is supported on heavy-duty integrally welded steel supports for sturdy floor mounting.

STEAM HEATING COIL

The water heater is supplied with a high-quality factory installed 2-pass U-tube heating coil constructed from 20-gauge ¾-inch O.D. single wall copper tubing designed for a maximum working pressure of 150 psi. The tubing is installed in a heavy-duty fabricated steel head with threaded NPT steam and condensate connections. Each assembly is fastened to a corresponding tank flange using a gasket and hex head steel bolts and nuts. Specialized heating coil construction may be included. These options include double wall tubing with a leak detection port, or special materials (stainless steel, 90/10 copper-nickel, other) for the tubes and/or head. See drawing for complete details.



STEAM OPERATING CONTROLS

The steam operating controls are factory selected, sized, piped, and tested to ensure reliable operation. Steam controls can be shipped loose, upon request, for in the field installation by others. All steam components are factory plumbed with schedule 40 black iron pipe and ready for steam and condensate connections. A cast iron 'Y' strainer with 20 mesh screen protects the steam controls and coil from dirt and debris in the steam supply.

TRAPS

Two traps should be utilized in the immediate steam piping system of the water heater. The first trap in the system is a drip trap that is designed to collect condensate from the main steam line before entering the steam regulator. Additionally, a main condensate trap should be located in the condensate line after the steam coil. This trap ensures that the steam remains in the coil and releases its energy before exiting the coil and traveling down the condensate line. There are various types of traps available. The following may be included in your water heater package:

1. Drip Trap

- a. Thermostatic (Standard)
- b. Cast Iron Float and Thermostatic type
- c. Cast Steel Float and Thermostatic type

2. Main Trap

- a. Cast Iron Float and Thermostatic type (Standard)
- b. Cast Steel Float and Thermostatic type
- c. Bucket

STEAM CONTROL VALVES

1. Pilot Operated (Standard) – A high-quality cast-iron pilot operated steam control valve comes with the standard unit. It is the most widely used type of valve for water heating applications. In this type of valve, a temperature pilot device utilizes steam to operate the main valve. No external power source is required other than steam. This highly dependable temperature control system is suitable for most commercial and industrial applications.
2. Self-Operating – This valve design includes a bulb and capillary assembly charged with a thermally responsive vapor. The expansion / contraction of the vapor acts upon the valve bellows in order to control the flow of steam through the valve. No external power is required for operation.
3. Pneumatically Operated – In this configuration the building air supply feeds a factory installed temperature controller that operates the steam control valve. The temperature controller sends a precise air signal to the steam control valve which adjusts the flow of steam into the heating coil. The temperature controller is fully adjustable from 50° - 250° F and requires 20 psi air at a maximum consumption of 0.5 SCFM.

4. Electronically Operated – This control valve is similar to a pneumatically operated system, except in this case the temperature controller is a sophisticated digital display electronic device which outputs a 4-20 ma signal to a compact motor mounted on the steam control valve in order to proportionally control the flow of steam to the heating coil. The temperature controller displays set point as well as actual water temperature and is available with an RS485 communications port for remote control.

OPTIONS

The following optional features may be included in your water heater. Refer to the drawing specific to your heater for further details.

Single Solenoid Safety System

A single solenoid safety system closes the steam supply to the control valve should the temperature in the tank reach the high limit set point. This option requires 120-volt, 5-amp electrical service.

Double Solenoid Safety System

A double solenoid safety system dumps over heated water in the storage tank to drain in addition to closing the steam supply to the control valve. This option requires 120-volt, 5-amp electrical service.

Anticipator Control System

The anticipator control system forces incoming cold water over the control valve sensing bulb in order to begin heating water immediately.

Skid Mounting Optionally, the unit may be mounted on heavy duty all welded I-beams.

Circulating Pump Package An intra-tank circulation pump package with On/Off switch to continuously circulate water within the tank and thereby reduce stratification may be installed. An all-bronze circulator pump.

Dial Temperature and Pressure Gauge

A combination temperature (70° - 250° F) and pressure (0 – 200 psi) gauge with 2½-inch dial may be factory installed in the tank.



SECTION II – INSTALLATION

WARNING / CAUTION

DO NOT TURN ON THE STEAM SUPPLY to this unit until heater is completely filled with water and all air has been released. *If the heater is NOT filled with water when the steam supply is turned on, damage to the heating coil may result.*

For protection against excessive pressures and temperatures, local codes require the installation of a temperature-and-pressure (T&P) relief valve certified by a nationally recognized laboratory that maintains periodic inspection of production of listed equipment of materials, as meeting the requirements for Relief Valves and Automatic Gas Shutoff for Hot Water Supply Systems. ANSI Z21.22-1971. THE CUSTOMER IS RESPONSIBLE TO PROTECT PROPERTY AND PERSONNEL FROM HARM WHEN THE VALVE FUNCTIONS.

All water heaters have a risk of leakage at some unpredictable time. IT IS THE CUSTOMER'S RESPONSIBILITY TO PROVIDE A CATCH PAN OR OTHER ADEQUATE MEANS, SO THAT THE RESULTANT FLOW OF WATER WILL NOT DAMAGE PROPERTY. If the unit is painted or insulated on the job site, care should be taken not to paint or insulate over the A.S.M.E. nameplate. This plate should be accessible and legible at all times to inspectors, and information from this plate must be used when ordering parts from the factory.

The tank should be fully drained in the event the steam has been turned off and if there is danger of freezing. If the tank is drained and to be left empty for more than 8 hours, at least 2-inches of water should be left in the bottom of cement lined tanks to prevent lining from drying and cracking.

WATER HEATER PLACEMENT

1. Adequate space should be provided for removal of the heating element.
2. Unit should be level to permit proper drainage.

PIPING INSTALLATION

NOTE: The most effective means for preventing deterioration from accelerated corrosion due to galvanic and stray current is the installation of dielectric fittings/unions. The installation of these fittings is the responsibility of the installation contractor.

1. All integral components have been properly sized to meet design conditions. Piping to the unit should be sized to meet the design conditions, as dictated by good engineering practices.
2. Refer to the enclosed drawing for location of piping connection.
3. Install the combination temperature and pressure safety relief valve in the tapping provided. Note that this is required by law for safety considerations.

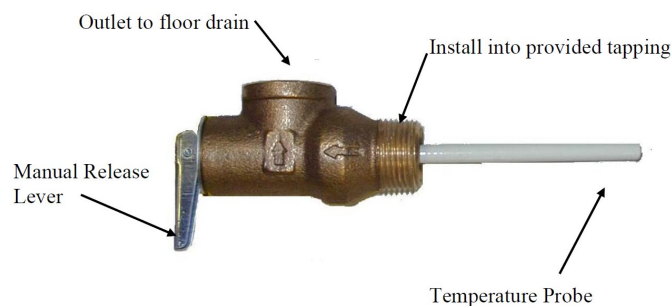

4. Install a relief valve overflow pipe to a nearby floor drain. **CAUTION:** No valve of any type should be installed between the relief valve and tank or in the drain line.

HOOK-UP OF AIR AND WATER OPERATED CONTROLS

- Most air or water operated valves on Hubbell water heaters are controlled by Powers Accritem. Occasionally, a Robertshaw Fultrol is furnished which operates identically to the Powers control except supply and output connections are reversed in location. Controls are normally mounted on the back side of the tank shell.

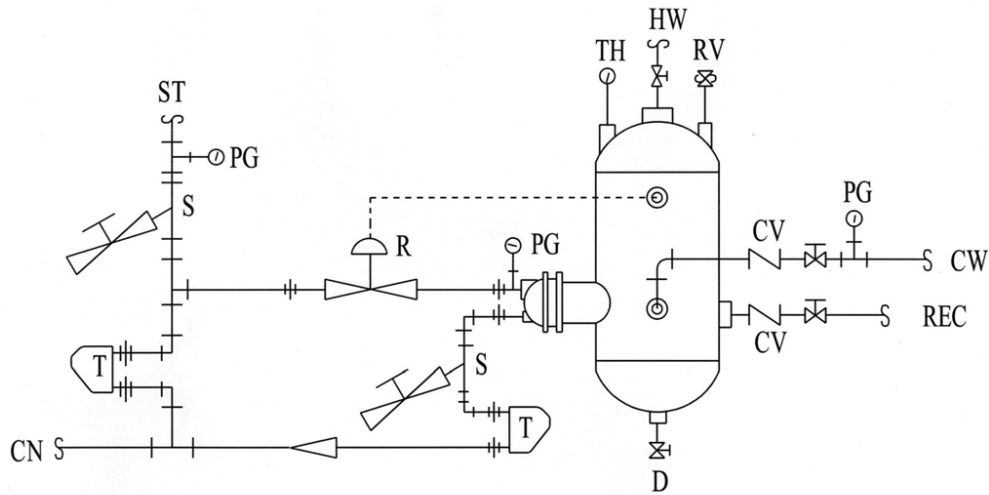
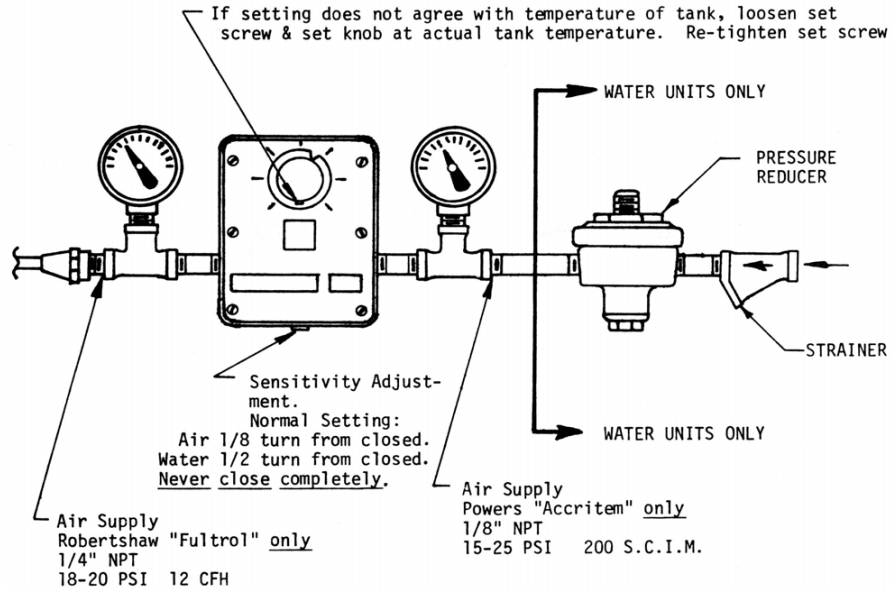

LEGEND:

- | | | |
|-------------------|-----------------|-------------------|
| S STRAINER | RV RELIEF VALVE | CW COLD WATER |
| T STEAM TRAP | PG PRESS. GAUGE | ST STEAM |
| R TEMP. REGULATOR | TH THERMOMETER | REC RECIRCULATION |
| D DRAIN | CV CHECK VALVE | |
| CN CONDENSATE | HW HOT WATER | |

Typical Piping Diagram

ELECTRICAL INSTALLATION

1. If the unit is furnished with a pilot or self-contained control valve, no external source of power is required for the valve. (See enclosed operation and maintenance manual for specific valves).
2. If the unit is furnished with an air or electric control valve, see enclosed drawings for required connections. (See enclosed operation and maintenance manuals for specific valves). Torque screws per torque chart included in Section VI.
3. All other electrical connections are made at the factory; therefore, no other electrical connections are necessary.

FILLING THE HEATER

1. Begin with all steam, condensate, and water valves closed.
2. Open the isolation valves on the integral circulator line ,if supplied.
3. Open cold-water valve, fill unit with cold water. Lift lever on relief valve to relieve trapped air. Release relief valve lever when all traces of air have been vented from the unit. Leave cold water valve open.

STARTUP

1. Turn pump switch to the "ON" position, if supplied. (Do not operate the pump without the unit being filled with water and isolation valves being opened, as damage to the pump could result).
2. Set control valve thermostat to approximately 30° F below desired temperature, observe unit. If the unit operates properly, gradually raise the set point to desired set point.
3. If the unit has a safety system, set the hi-limit thermostat to desired temperature. (This thermostat must be set at a higher temperature than the operating thermostat or the unit will never reach the desired temperature). Refer to the enclosed piping and wiring drawings.
Gradually open valve to allow heating medium to enter the heating element. (Boiler water lines should be vented to eliminate trapped air). Monitor the tank temperature until the desired temperature is reached. If the temperature regulator shuts off before the desired temperature is reached, or if over-shoot occurs, adjustment of the temperature regulator will be required. (Refer to enclosed O&M manuals for your specific control valve).
4. After control valve adjustments have been made and the desired temperature has been reached, open the valve on the hot water outlet and the building recirculation line.
5. Tightening of some gasketed joints may be required after the unit has been heated.
6. Never break any joint, gasketed or screwed on unit until the pressure in the unit has been reduced to zero and the unit drained.
7. Observe operation of unit for 30-40 minutes after initial startup.

SHUTDOWN

1. Close valve to heating medium and air supply valve if air operated controls are furnished.
2. Disconnect all electrical power to unit.
3. Close hot water outlet valve.
4. Close building recirculation inlet valve and shut down building circulation pump.
5. Close cold water inlet valve.
6. Turn off the pump, if supplied.
7. Drain unit by lifting lever on relief valve to vent tank, then slowly open drain valve.

SECTION III – SCHEDULED MAINTENANCE AND SERVICING

WARNING / CAUTION

Before performing any maintenance procedure, make certain steam supply and electrical power supply is **OFF** and cannot accidentally be turned on.

QUARTERLY INSPECTION

1. Monitor thermostat
 - a. Let the water heater completely heat to a designated thermostat setting.
 - b. After the thermostat satisfies (that is, when the thermostat actually clicks off), draw water from heater.
 - c. Compare the water temperature of drawn water to the temperature setting of the thermostat when it satisfies. Normal variation between the two points is approximately + 5°F.
 - d. If these two readings do not coincide within acceptable tolerances and verification has been made of the accuracy of the temperature-reading gauge, replace the thermostat.
2. Lift test lever on relief valve and let water run through valve for a period of approximately 10 seconds. This will help flush away any sediment that might build up in water passageways.

ANNUAL INSPECTION

1. Units subject to fouling or scaling should be cleaned periodically. A marked increase in pressure drop and/or reduction in performance usually indicates cleaning is necessary.
2. To clean inside of tubes, remove all heads and covers. (**Caution: Do not loosen heads until you are sure all pressure is off the equipment, and the unit is drained**).
3. In cleaning a tube bundle, tubes should not be hammered on. If it is necessary to use scrapers, care should be taken to ensure that the tubes are not damaged.
4. Before it is necessary to apply mechanical means for cleaning, try to clean the unit using the following methods.
 - a. Circulate hot fresh water at a reasonable velocity.
 - b. Try spraying with a water hose.
 - c. Consult with manufacturers of cleaning compounds and chemicals. They will check the nature of the deposit, recommend the right cleaning compound, and in many cases provide equipment and personnel for a complete cleaning job.
5. Do not clean tubes by blowing steam through individual tubes.
6. To tighten a loose tube joint, use a suitable roller type tube expander. Do not roll tubes that are not leaking. If double wall tubes are supplied return to the factory for repairs.
7. If the unit is dismantled for any reason, it should be reassembled using new gaskets.
8. Do not tighten bolts until gaskets are properly seated.
9. The exterior of the unit should be cleaned and if necessary repainted.
10. When tightening bolts in the element head, tighten the bolts in a crisscross pattern. This will evenly distribute pressure around the flange and help prevent warping. See diagram on following page.

|----- FT/LBS -----|

<u>BOLT SIZE</u>	<u>STEP 1</u>	<u>STEP 2</u>	<u>FINAL</u>
5/8"	60	96	120
3/4"	100	160	200
7/8"	160	256	320
1"	245	392	490
1 1/8"	355	568	710
1 1/4"	500	800	1000
1 3/8"	680	1088	1360

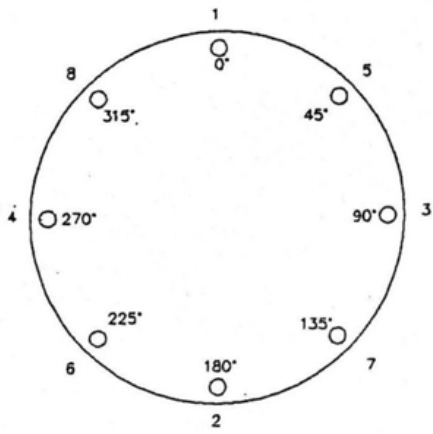

8-BOLTS

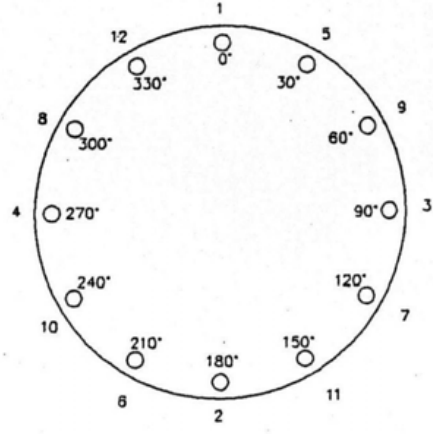

12-BOLTS

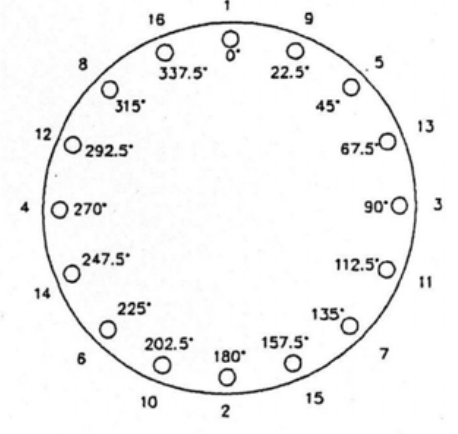

16-BOLTS

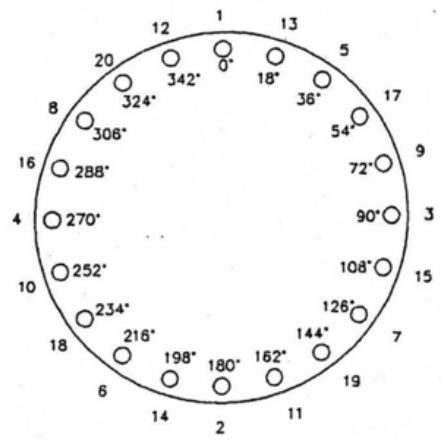

20-BOLTS

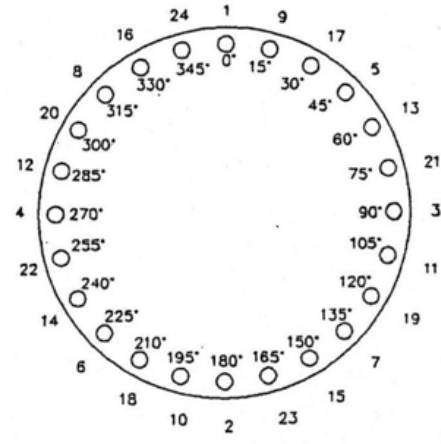

24-BOLTS

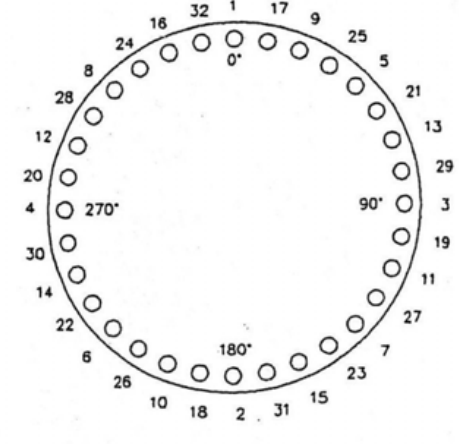

32-BOLTS

11. Convection packages may be equipped with an integral circulator. This circulator should be serviced per the enclosed pump O&M manual.
12. The unit as well as all strainers should be blown down regularly to remove any trash, and sediment that may have accumulated.
13. If the unit is supplied with an anode rod, it shall be inspected for excessive wear.
14. Packing on valves and regulators should be checked for leaks and repaired or replaced as necessary.
15. To seal the manhole gasket, first install the cover, crab, new gasket, bolt, and nut. Turn the nut until it is snug against the crab, then turn 1 ½ revolutions. Fill the tank with water and allow pressure to build up, letting the water pressure seal the gasket. (Some leakage may occur at this point, but as the gasket seats, leaking will gradually stop). After leaking has stopped, turn the nut approximately 1 revolution. At this point there may be some minor seepage, wait a few minutes to see if this seepage stops. If seepage continues drain the tank, inspect the manhole ring, and cover for any damage, (repair or replace as required) Repeat the above procedure using a new gasket.

Never try to seal the cover solely by turning the nut down tight this may cut or crush the gasket and make sealing impossible.

16. Drain and flush tank as follows. Perform annually or more often , if required. **NOTE:** Cement lining is a durable lining that will provide many years of service protecting your steel pressure vessel from corrosion. The process of cement lining includes an inspection to ensure that the lining is applied to the correct thickness, covers all appropriate surfaces, and is free from defects or cracks greater than 3 mm (1/8”) in width. Any deficiencies are repaired at the factory prior to shipment. However, it is characteristic to find hairline cracks in the cement lining prior to initial installation. After the vessel is first filled, the water will work its way into these cracks and begin the corrosion process. At the same time the cement lining undergoes a “wet curing” process whereby the cement absorbs water and expands. The water that is absorbed into the lining becomes trapped between the cement lining and the steel tank and once the cement is fully absorbed with water, the water in contact with the steel tank becomes deoxygenated which serves to protect the steel vessel. In addition, the cement leaches minerals and various impurities from the water which fills and “heals” the cracks. This “healing” together with the “wet curing” and expansion of the cement prevents any ongoing corrosion. In the unlikely event a crack greater than 3 mm (1/8”) develops, the cement lining can be easily repaired in the field. For repair procedures please contact Hubbell.
 - a. Shut down unit as described in Section II.
 - b. Close valve on hot water outlet piping.
 - c. Open valve on drain piping.
 - d. Cold water inlet line pressure will be strong enough to flush sediment from the bottom of the tank out through the drain. Let the water run for 3-4 minutes.
 - e. Clean strainer filter, see below.
 - f. Close drain valve.
 - g. Open hot water valve.
 - h. Re-start unit as described in Section II.

17. Clean strainer filter. Perform annually or more often, if required.
- a. Remove blowoff bushing (E) or cap (F), as required.
 - b. Remove gasket (B), if required.
 - c. Remove, clean, and re-install screen (A).
 - d. Replace gasket (B).
 - e. Re-install blowoff bushing (E) or cap (F), as required.

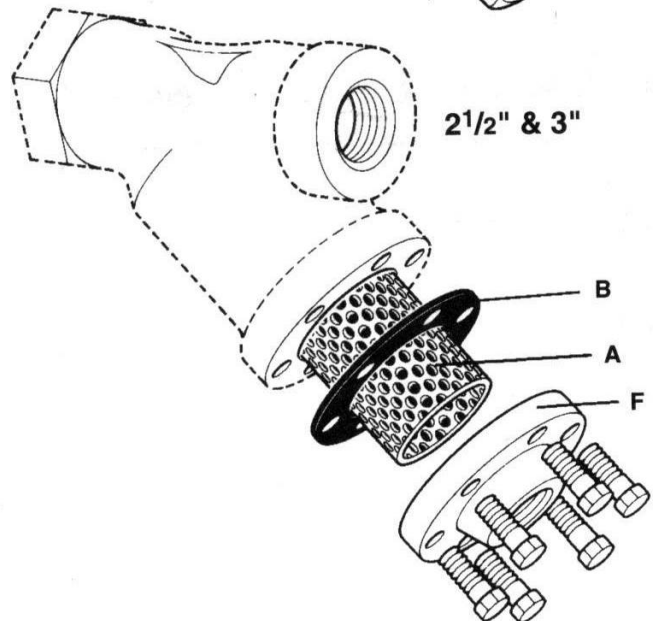
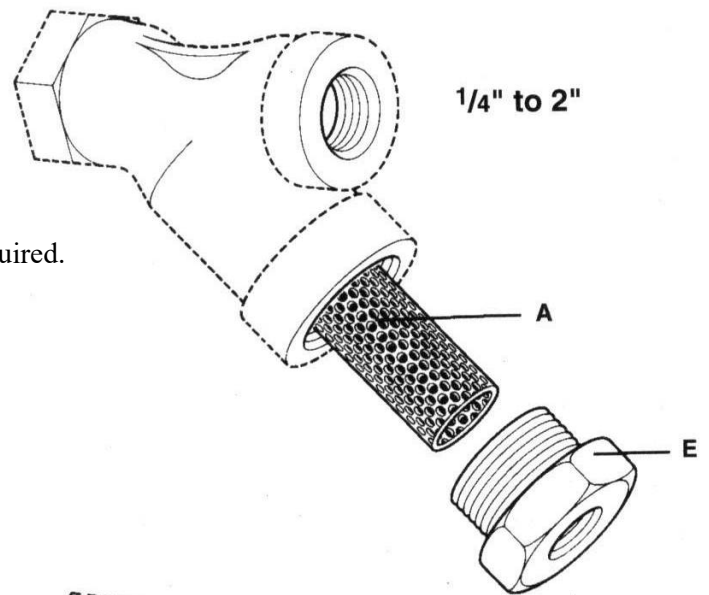

GENERAL CONFIGURATION OF STANDARD U-TUBE HEATING ELEMENTS

2-PASS

TOP

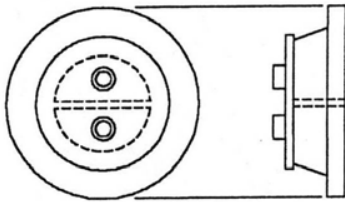

HEAD

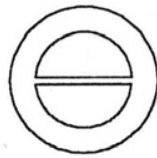

GASKET

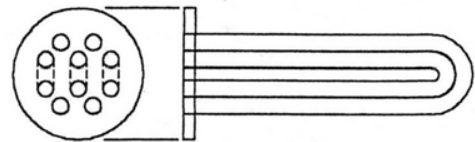

TUBE SHEET

4-PASS

TOP

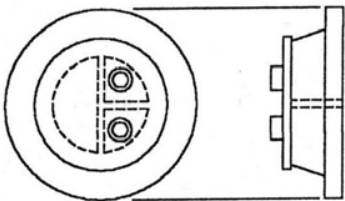

HEAD



GASKET

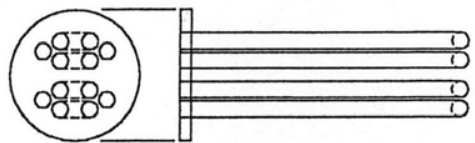

TUBE SHEET

6-PASS

TOP

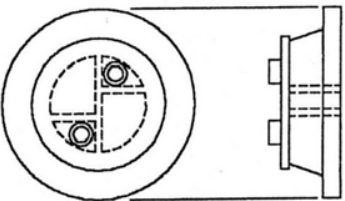

HEAD



GASKET

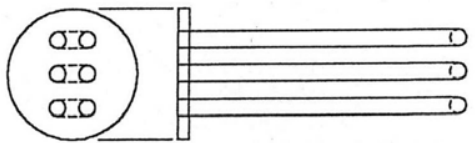

TUBE SHEET

UNLESS SHOWN DIFFERENTLY ON THE DRAWING, THIS CONFIGURATION SHOULD BE CLOSELY FOLLOWED WHEN INSTALLING HEATING ELEMENTS.

SINGLE SAFETY SOLENOID SYSTEM (if installed)

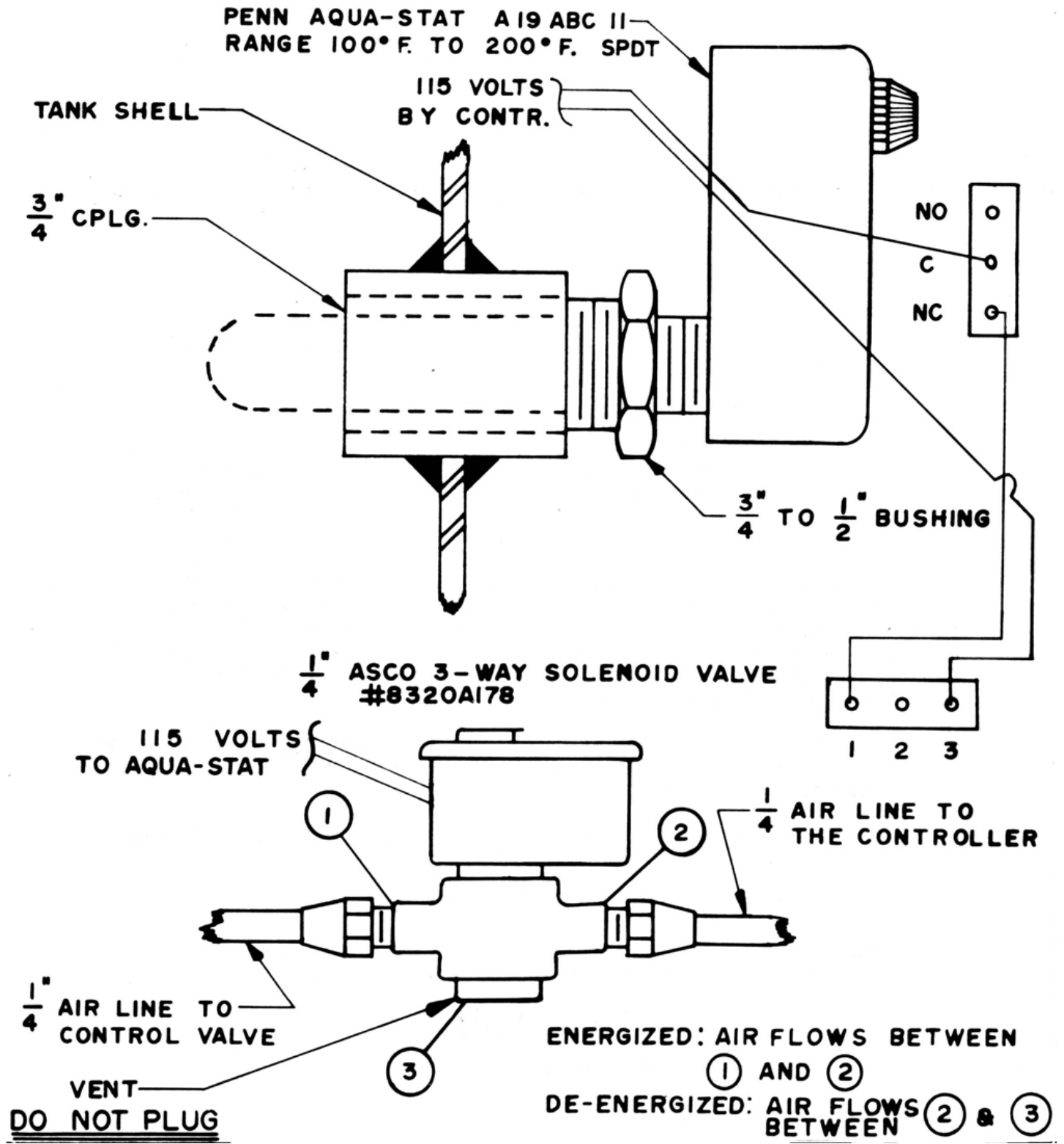

DOUBLE SAFETY SOLENOID SYSTEM (if installed)

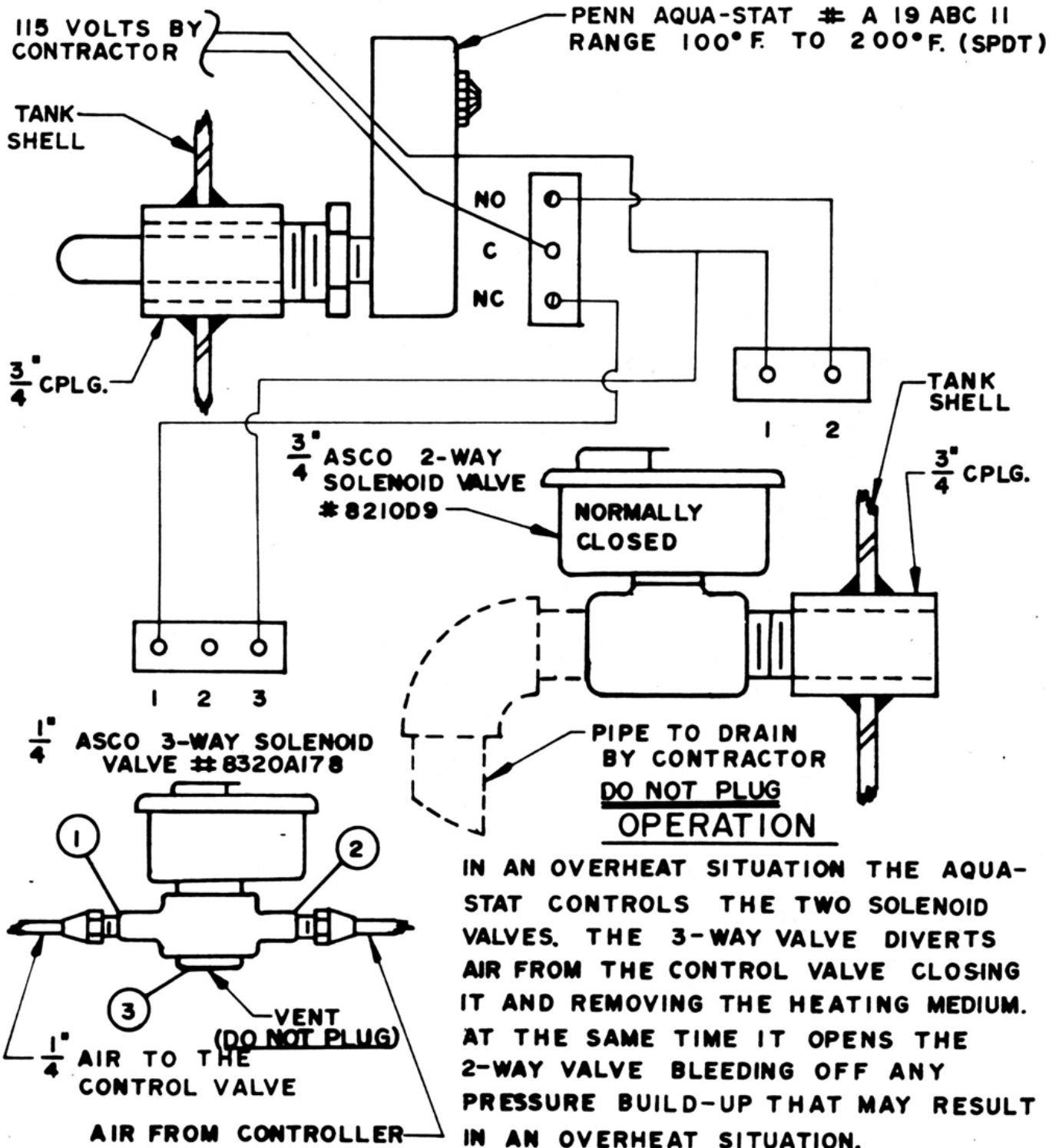

SECTION IV – ADJUSTMENT OF TEMPERATURE REGULATORS

1. The spring tension on temperature regulators is adjusted at the factory to meet design conditions. However, design conditions may vary from actual operating conditions and re-adjustment might be required on this job.
2. Whenever possible, Hubbell uses “fail safe” regulators. This means that if the controlling medium, such as air or water is lost, the valve will close under its own spring tension.

ADJUSTMENT OF 2-WAY AIR OR WATER OPERATED VALVES

1. Release all air pressure from the diaphragm.
2. Apply steam pressure to the valve.
3. If at this point, there is pressure on the downstream side of the valve, or if steam can be heard passing through the valve, valve spring tension needs to be increased.
4. Turn the spring adjustment screw slowly to increase spring tension until the pressure on the downstream side of the valve has dropped to “0” and there is no sound of flow through the valve. Do not turn spring adjustment past this point. If the valve will not open with air on the diaphragm, spring is adjusted too tightly.
 - a. Release all air pressure from the valve diaphragm.
 - b. Apply steam pressure to the valve.
 - c. Loosen tension on the spring until steam begins to seep through the valve.
 - d. Slowly, tighten spring tension until flow stops.
 - e. Do not turn spring adjustment past this point.

ADJUSTMENT OF 3-WAY AIR OR WATER OPERATED VALVES

1. Turn thermostat down so that no air pressure is on the valve diaphragm. If the unit continues to heat, valve spring tension needs to be increased.
2. Shut off the heating medium.
3. Disconnect stem coupling (A).
4. Lift lower stem (B) and hold against upper valve seat.
5. Turn adjustment screw (C) until there is approximately a 1/16-inch gap between the two stem halves.
6. Apply air pressure to valve diaphragm so that stem halves are aligned and re-connect stem halves.
7. If valve will not open with air on the diaphragm, spring tension should be decreased.
8. Adjustment is essentially the same as if spring tension were increased except the adjustment screw is turned in the opposite direction.

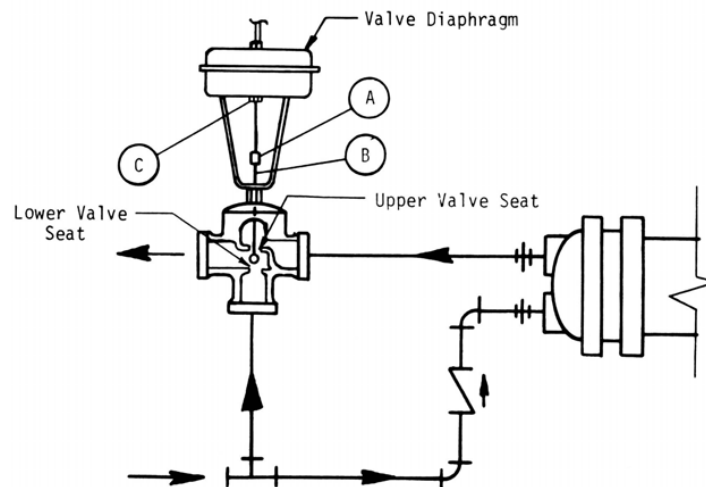

ADJUSTMENT OF PILOT OPERATED VALVES

1. Pilot operated valves such as Spence or Spirax/Sarco are not fail safe. These valves have a liquid or gas filled thermo-static bulb and if this bulb loses its charge, the valve will go to its fully open position and cause overheating of the water heater. This situation should be considered before attempting to adjust these valves.
2. Spirax/Sarco Valves are completely pre-set at the factory and there is no spring adjustment. Set the thermostat at the desired temperature and no further adjustment is required.
3. Spence Valves: There is no main spring adjustment on Spence Valves. To set temperature on the water heater:
 - a. Turn pilot spring adjustment "A" clockwise until all tension is off the spring.
 - b. Refer to unit start-up section and start unit except for thermostat setting.
 - c. Turn spring adjustment "A" counterclockwise until the wheel is firmly against the spring.
 - d. Continue to turn wheel "A" one 360° turn or until steam begins to pass through the valve.
 - e. Allow unit to heat until the valve closes off.
 - f. If unit is not up to temperature at this point, continue to turn adjustment wheel ½ turn, stop and allow valve to shut off.
 - g. Repeat this cycle until the unit is up to the desired temperature.

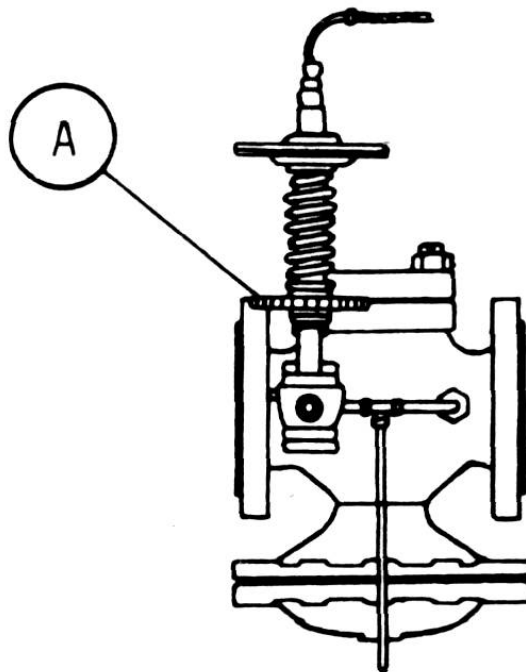

SECTION V – TROUBLESHOOTING

(See separate component O&M for additional details.)

Symptom	Probable Cause	Corrective Action / Remedy
Gradual loss of heating capacity.	Tubes are fouled.	Clean tubes per Section III, annual scheduled maintenance.
	Excess silt in bottom of tank.	Drain and flush tank per Section III , annual scheduled maintenance.
	Air or water leak in temperature control.	Repair or replace per separate O&M.
	Ruptured diaphragm on air or water operated valve.	Repair or replace per separate O&M.
	Debris in Accritem.	Clean Accritem.
	Strainers clogged.	Clean strainers per Section III, annual scheduled maintenance.
	Pump impellor deteriorated.	Repair or replace per separate O&M.
Overheating	Temperature regulator has lost its charge, self-contained valves only.	Repair or replace per separate O&M.
	Ruptured tube(s) in heating coil.	Remove / replace heating coil.
	Temperature regulator needs adjusting.	Adjust temperature regulator per Section IV.
	Circulator not operating.	Repair or replace per separate O&M.
	Debris under seat of temperature control valve.	Repair or replace per separate O&M.
	Capillary tube pinched on temperature control.	Repair or replace per separate O&M.
Immediate loss of heating capacity.	Rib blown out of tube side gasket.	Remove heating coil and replace gasket.
	Capillary tube pinched on temperature control.	Repair or replace per separate O&M.
	Ruptured diaphragm on temperature control valve.	Repair or replace per separate O&M.
	Defective steam trap.	Repair or replace per separate O&M.
	Blockage in condensate line.	Clean blockage from condensate line.
	Loss of air pressure on temperature regulator.	Check air pressure to temperature regulator. Verify that it is within limits. Adjust as necessary.
Excessive vibration.	High rate of flow beyond design conditions.	Consult factory.
	Under sized piping to the unit.	Re-pipe lines to unit using proper sized lines.
Water hammer.	Defective steam trap.	Repair or replace per separate O&M.
	Undersized condensate lines.	Re-pipe condensate line using proper sized lines.
	Insufficient slope on condensate lines causing backup.	Increase slope on condensate lines.

* Red symptom indicates that equipment should be shut down immediately and cause of malfunction corrected before unit is re-started or serious damage may result.

SECTION VI – MISCELLANEOUS CHARTS AND FORMULAS

TORQUE VALUES

BOLT SIZE	18-8 S/S IN.-LBS.	BRASS IN.-LBS.	SILICON BRONZE IN.-LBS.	ALUMINUM 2024-T4 IN.-LBS.	316 S/S IN.-LBS.	MONEL IN.-LBS.
4-40	5.2	4.3	4.8	2.9	5.5	5.3
4-48	6.6	5.4	6.1	3.6	6.9	6.7
5-40	7.7	6.3	7.1	4.2	8.1	7.8
5-44	9.4	7.7	8.7	5.1	9.8	9.6
6-32	9.6	7.9	8.9	5.3	10.1	9.8
6-40	12.1	9.9	11.2	6.6	12.7	12.3
8-32	19.8	16.2	18.4	10.8	20.7	20.2
8-36	22.0	18.0	20.4	12.0	23.0	22.4
10-24	22.8	18.6	21.2	13.8	23.8	25.9
10-32	31.7	25.9	29.3	19.2	33.1	34.9
1/4-20	75.2	61.5	68.8	45.6	78.8	85.3
1/4-28	94.0	77.0	87.0	57.0	99.0	106.0
5/16-18	132	107	123	80	138	149
5/16-24	142	116	131	86	147	160
3/8-16	236	192	219	143	247	266
3/8-24	259	212	240	157	271	294
7/16-14	376	317	349	228	393	427
7/16-20	400	327	371	242	418	451
1/2-13	517	422	480	313	542	584
1/2-20	541	443	502	328	565	613
9/16-12	682	558	632	413	713	774
9/16-18	752	615	697	456	787	855
5/8-11	1110	907	1030	715	1160	1330
5/8-18	1244	1016	1154	798	1301	1482
3/4-10	1530	1249	1416	980	1582	1832
3/4-16	1490	1220	1382	958	1558	1790
7/8-9	2328	1905	2140	1495	2430	2775
7/8-14	2318	1895	2130	1490	2420	2755
1-8	3440	2815	3185	2205	3595	4130
1-14	3110	2545	2885	1995	3250	3730

METRIC CONVERSIONS

Liters x 0.2641 = Gallons	Bar x 14.5 = psi
Gallons x 3.79 = Liters	psi x 6.86 = kPa
Gallons x 0.003785 = m ³	kPa x 0.1456 = psi
m ³ x 264.2 = Gallons	Lbs x 0.4536 = Kg
1°C ΔT = 1.8°F ΔT	Kg x 2.2 = Lbs
°F = (°C x 1.8) + 32	ft ² x 0.0929 = m ²
°C = (°F - 32) x 0.556	m ² x 10.765 = ft ²
psi x 0.06896 = Bar	

HUBBELL ELECTRIC HEATER COMPANY
45 SEYMOUR STREET
STRATFORD, CT 06615

PHONE: (203) 378-2659
FAX: (203) 378-3593
Hubbellheaters.com