

GAS-HX

CONDENSING / PROPANE & NATURAL GAS

GAS HEAT EXCHANGER
FOR COMMERCIAL AND INDUSTRIAL APPLICATIONS



HUBBELL HX

Gas Burner

Hubbell's 316L stainless steel heat exchanger/burner is unlike others on the market due to its unique features and high-grade construction. This exchanger is the perfect solution for your gas fired water heating application because it is fully removable, making it quick and easy to clean, maintain, and service in the field. The burner can also be repaired and replaced without having to remove your water heater, making the process simple compared to other heat exchangers which are permanently welded to the tank's pressure vessel. The minimally welded area of the heat exchanger also reduces the potential for failure, ensuring you have a long-lasting component which provides maximum reliability and sustained peak performance.

**MADE IN THE
USA**

*By American Act Compliant
May Contain Imported Components



Features & Benefits

- High efficiency fully modulating 316L SS heat exchanger
- 94% efficiency
- 55,000 BTU/HR input
- Natural Gas or Propane (field convertible)
- Digital temperature controller (120Volt 5AMP required)
- 5 year non-prorated heat exchanger warranty
- 1 year non-prorated parts warranty
- Made in the USA

GAS HX Dimensional Data

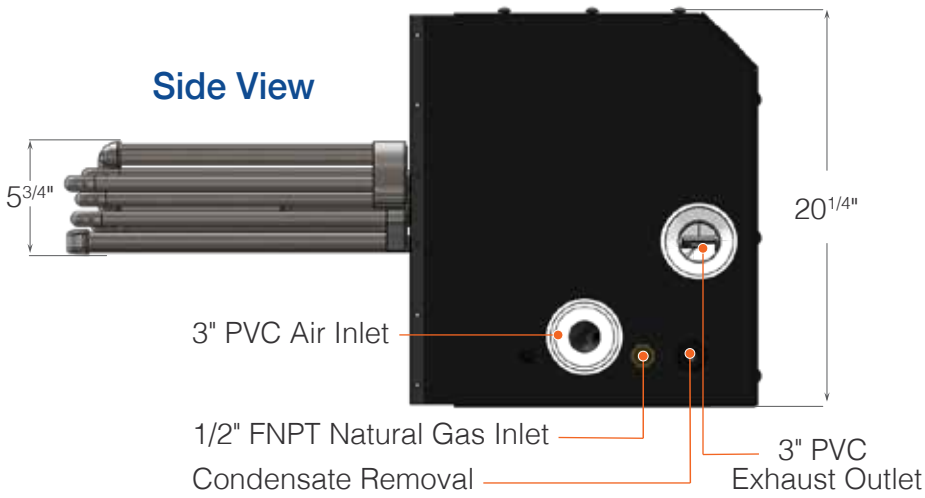
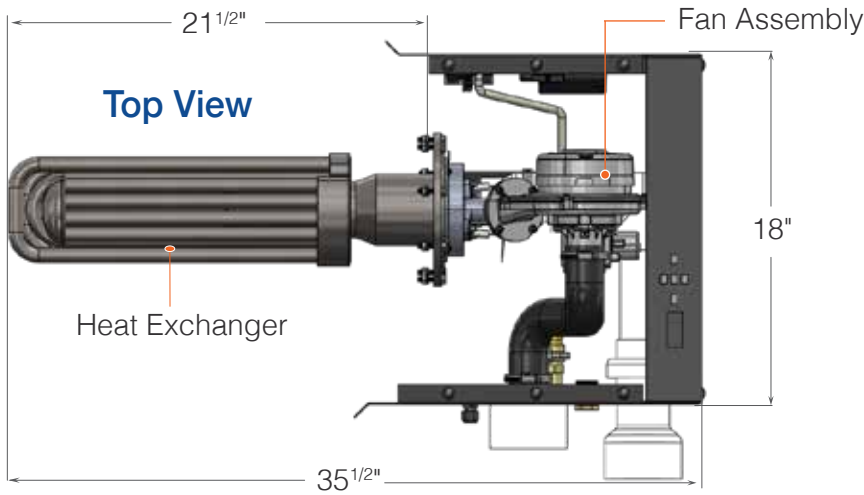

Shown with a cement-lined steel Tank

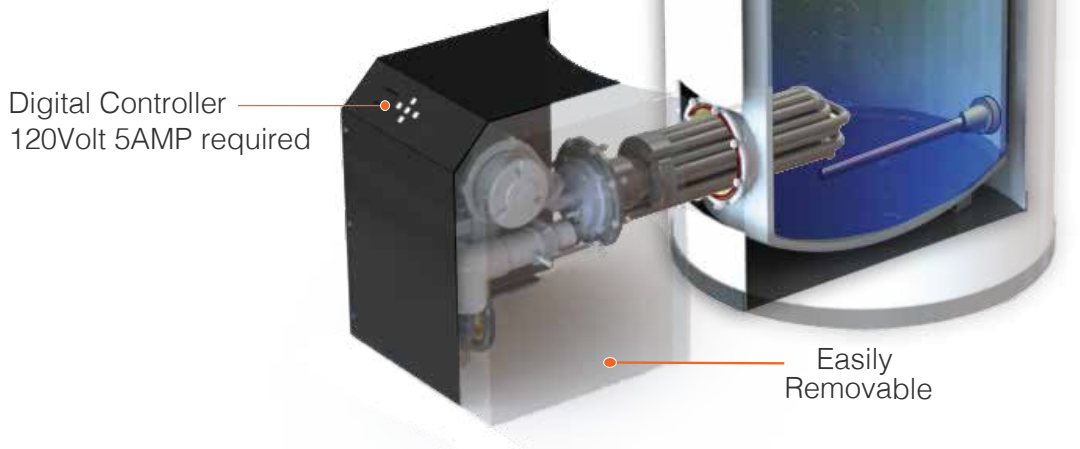

Component Information

Part #	Btu/hr input	Continuous Recovery 40-140°F	EF Rating	Working Pressure PSI	Fuel Source
GAS -HX 551SSA22- NG	55,000	62	94%	150	Natural Gas
GAS -HX 551SSA22- P	55,000	62	94%	150	Liquid Propane